

## VA-8050 Electric Valve Actuator Floating Control, 50 lb. Force

The VA-8050 synchronous, motor-driven actuator provides floating control of valves with up to 3/4 in. stroke in heating, ventilating, and air conditioning applications. This compact, non-spring return actuator has a 50 lb. force and requires a 3-wire, 24 VAC signal from the controller. The VA-8050 can be ordered factory coupled to VB Series valves. Refer to AV-8050 bulletin for available configurations.

### Operation

A controller sends 24 VAC to the up or down terminal on the circuit board depending on the desired movement of the valve. This signal causes the motor to rotate in the proper direction, and through the lead screw and lever, move the valve up or down. When the controller stops sending a signal, the valve remains in place.

When the controller closes the valve, a shutoff force will build up. When this force reaches 50 lbs., the lever activates a force sensor which stops the motor. Field calibration of the force sensor is not required. The actuator maintains the shutoff force even if power to the controller is lost. When the controller signals the valve to move in the opposite direction, the shutoff force will be reduced and the valve will modulate.

### Wiring

All wiring must be in accordance with applicable electrical code requirements. Input lines to the actuator must be wired correctly to the valve to move in the proper direction. Wiring is to a terminal strip labeled COM



**Fig. 1: VA-8050-1 Connected to VB-3754**

(Common), UP and DOWN, respectively.

### Specifications

<b>Product</b>	VA-8050-1 Electric Valve Actuator Assemblies
<b>Control Mode</b>	Floating Control, 3-Wire
<b>Supply Voltage</b>	24 VAC +6 V, -4 V, <200 mA, 50/60 Hz
<b>Power Consumption</b>	6 VA
<b>Shutoff Force</b>	50 lb. Force Minimum
<b>Stroke Time</b>	1/2 in. Stroke: Approx. 65 Sec 3/4 in. Stroke: Approx. 90 Sec
<b>Ambient Operating Temperature</b>	0 to 140°F (-18 to 60°C), 10 to 90% RH Non-Condensing, 85°F Max Dew Point
<b>Ambient Storage Temperature</b>	-40 to 150°F (-40 to 65°C)
<b>Media Temperature</b>	Water: 190°F (88°C) Steam: 280°F (138°C)
<b>Accessories</b>	VA-8000-101 Steam Insulator Kit VA-8000-102 Valve Position Indicator Kit VA-8000-104 Auxiliary Interface Board

The performance specifications are nominal and conform to acceptable industry standards. For application at conditions beyond these specifications, consult the local Johnson Controls office. Johnson Controls, Inc. shall not be liable for damages resulting from misapplication or misuse of its products.

**hvacUSA.com**  
 A MechTronics Controls Company

[www.hvacusa.com](http://www.hvacusa.com)  
 Phone (877) 632-4876

## Retrofit Installation

**CAUTION:** Do not use on valves having a stroke over 3/4 in. Actuator travel over 3/4 in. will damage the actuator.

**WARNING:** Equipment Damage Hazard. Do not drive the VA-8050 actuator unless it is mounted to a valve. This can result in permanent damage to the actuator.

1. Remove the V-3000 actuator, upper spring plate and spring.(See Fig. 2).
  - a. Disconnect the air line to the actuator.
  - b. Remove the actuator by loosening the actuator set screw on the bottom of the lower diaphragm case. Lift the actuator off of the valve.
  - c. Hold the stem extension firmly with a 9/16 in. box-head wrench and with a small screwdriver, loosen the stem locking screw.
  - d. For V-3000 valves, compress the spring using the X-200-8058 spring compression tool. For V-3800 valves, compress the spring with hand pressure.
  - e. Using a 9/16 in. box-head wrench, unscrew the stem extension. Lift the spring and upper spring plate off the valve. Remove the spring compression tool if used.
  - f. Thread the lower spring plate up the centerpiece stuffing box to increase spacing between the spring

plate and the flat valve yoke mounting surface.

2. Unpack the actuator and make sure the lever plate is within 1/4 in. of the upper stop.
3. Install the valve packing that is provided according to the instructions included with the parts.
4. Thread the 1/4 in. Palnut, open side down, onto the valve stem and all the way to the end of the threads.
5. Loosely install the actuator by sliding the actuator yoke between the spring plate and the yoke surface. Finger tighten the plate to hold the actuator in place. (See Fig. 3).
6. Obtain a source of 24 volt AC power. Wire a switch to allow control of the 24 volts AC to the DOWN and COM terminals of the actuator.
7. Thread the coupler onto the valve stem while applying 24 volts AC as necessary. The coupler should thread down the stem until approximately 1/8 in. of thread remains between the coupler and the Palnut.

8. Reverse the actuator and drive it up until it stops on the limit switch. Check to make sure the gap between the lever plate and the molded upper stop is 1/16 in. (.047 to .093 in.). Set with flat washer gage supplied. (See Fig. 5). Repeat steps 6, 7 and 8 until the gap falls into this range when the actuator stops.
9. With the valve driven fully up to hold tension on the stem and coupler, thread the Palnut up the stem until it contacts the coupler. Tighten Palnut to coupler with 1/2 in. and 7/16 in. wrenches.
10. Secure the actuator in place by tightening the spring plate with a large screwdriver.(See Fig. 3).
11. Drive the actuator fully up and down at least three complete cycles before again checking that the lever and its drive coupler stop before contacting the upper stop and the lower end of the yoke casting.

**CAUTION:** Use VA-8000-101 Insulator Kit for steam applications 280°F (138°C) Maximum.

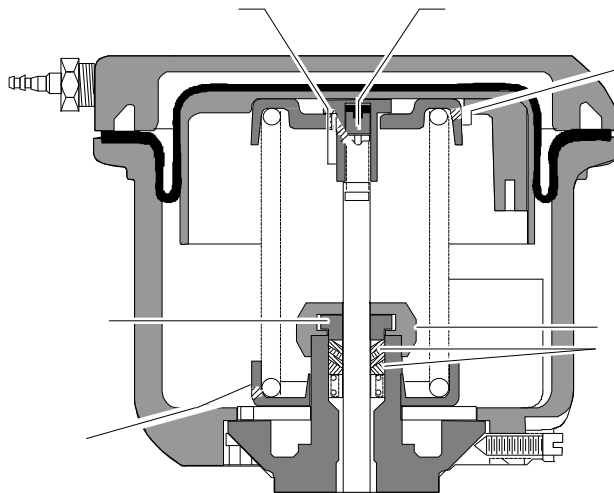

Fig. 2: Exposed V-3000 Actuator

## Repair Information

Field repairs must not be made. For a replacement VA-8050, contact the nearest Johnson Controls branch office.

## Application and Drawing Identification

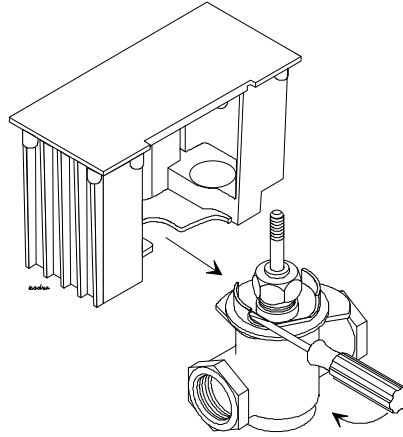
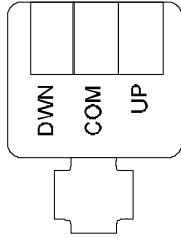

Fig. 3: Isometric Drawing

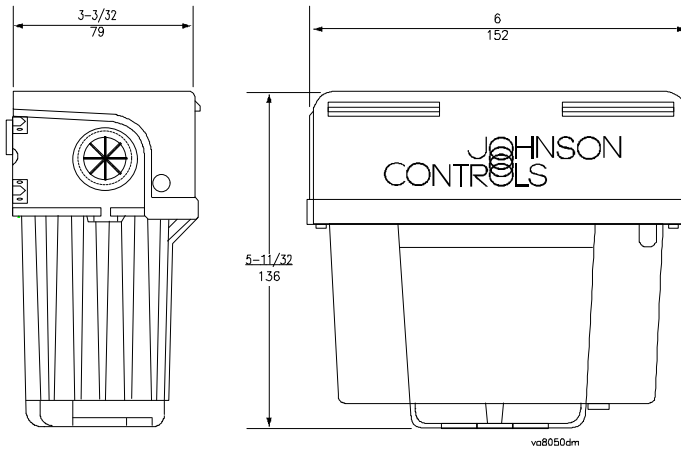

Fig. 4: VA-8050-1 Dimensions in./mm.

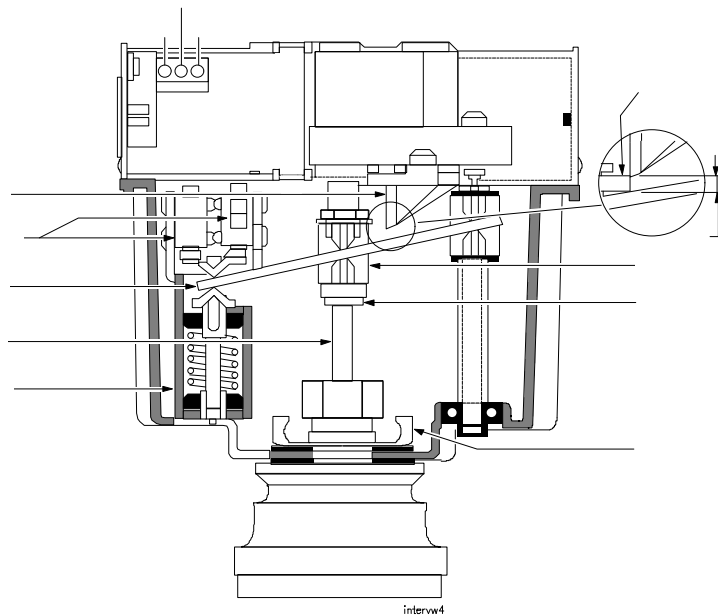
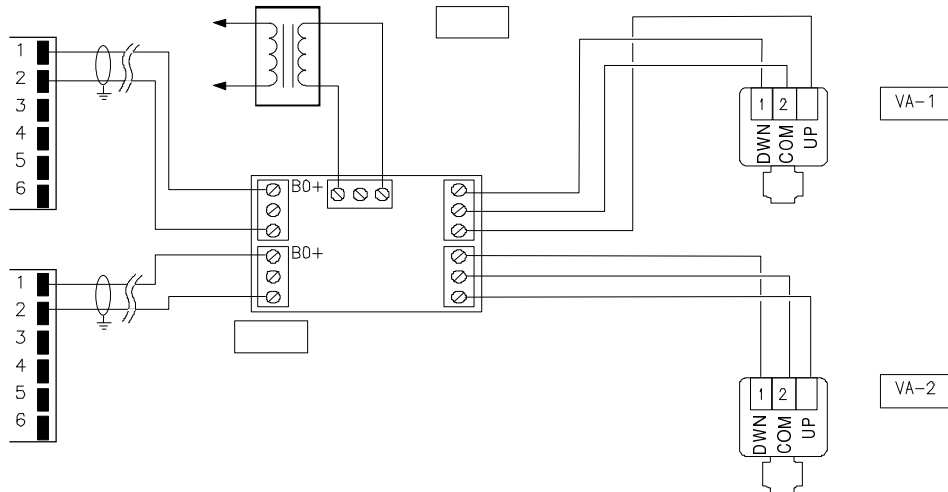
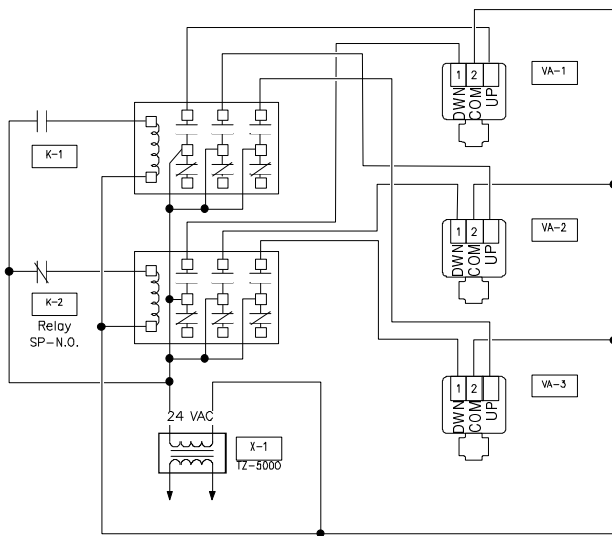

Fig. 5: Internal View

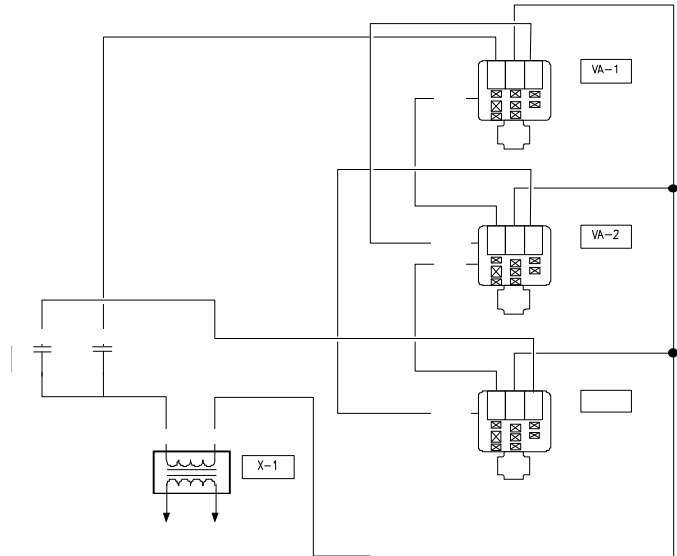

**Fig. 6: Incremental Control from DSC-8500**

**Note:** Hard ground cable shields to the wall of the DSC enclosure at the point of entry. The length of each shield inside the enclosure must be less than 2 in.



**Fig. 7: Unison Operation of Multiple Valves**



\* Brown and violet leads are tied to other wires internally. Use only for sequencing applications

**Fig. 8: Multiple Valves Sequenced from a Common Control**

**JOHNSON  
CONTROLS**

**Controls Group**  
507 E. Michigan Street  
P.O. Box 423  
Milwaukee, WI 53202

Printed in U.S.A.