

## Series 2200 Relative Humidity and Temperature Room Units For APOGEE® Controllers

### Product Description

These room units measure relative humidity and temperature in the occupied space in which they are installed. Models with display allow users to view the measured temperature value. A version with temperature setpoint adjustment is also offered.

These devices are intended for use with appropriate signal input on an APOGEE Controller. The effective sensing range is 32°F to 122°F (0°C to 50°C), and the setpoint range is 55°F to 95°F (13°C to 35°C).

These room units can be mounted on electrical boxes, stud-type mounting brackets, or drywall. Obtain the necessary mounting hardware and follow the appropriate mounting procedures for the type of installation required.

### Product Numbers

QFA3212.FWSN	QFA32SS.FWSN
QFA3212.EWSN	QFA32SS.EWSN

### Accessories

AQA2200-INTL	Room Unit Back Plate (10-pack)
AQA2200-2X4	Room Unit Back Plate (Single)
563-102 GSKT Kit	Room Sensor Insulating Gasket (10-pack) (For hollow wall installations)

**NOTE:** If installing the Back Plate, discard the metric screws provided with the Back Plate and utilize the Room Unit mounting screws.

### Caution Notations

<b>CAUTION</b>		Equipment damage or loss of data may occur if you do not follow a procedure as specified.
----------------	---	---

### Expected Installation Time

20 minutes

### Required Tools

- Sizes 1 and 2 Phillips screwdrivers
- Small and medium flat-blade screwdrivers
- 1/16-inch hex key
- Medium-duty electric drill
- 3/16-inch (4.8 mm) drill bit
- One-inch (25 mm) hole saw
- Small level
- Tape measure
- Marker or pencil

### Prerequisites

- Review these instructions before beginning.
- Installed: appropriate field wiring within the maximum wiring run length for the individual equipment controller. The maximum recommended length is 750 feet (229 m) for 18 AWG; 300 feet (91 m) for 22 AWG.
- All wiring must comply with National Electric Code (NEC) and local regulations.



Figure 1. Typical Temperature Room Unit.

## Mounting Information

Always mount the room unit vertically.

Locate the room unit:

- according to design specifications and local regulations.
- where the air circulates around it freely (not in recessed areas or behind doors).
- allowing a minimum of 4 inches (10 cm) free space above and below for proper airflow, the front cover removal tool, and the computer communication cable.
- away from drafts caused by doors, windows, outside walls, air registers, pipes, return air plenums, etc.
- away from heat sources such as strong lights, fireplaces, direct sunlight, etc.
- on an inside wall (preferably), about 5 feet (1.5 m) above the finished floor.

## Drywall Mounting (No Rough-in), Typical

### Base Plate Mounting and Wiring

1. Mark the center (cable) hole and the mounting hole locations, using the room unit base plate as a template. See Figure 3.
2. Drill two 3/16-inch (4.8 mm) mounting holes and mount the two plastic wall anchors flush to below the wall surface for stable mounting of the device.
3. Cut a 1-inch (25 mm) center hole with a hole saw.

**NOTE:** It is recommended that you use the optional Insulating Gasket on the back of the Sensor Base for hollow wall installations.

When applying the adhesive-backed gasket to the back of the Sensor Base, orient the gasket so that the cut-out arrow portion of the gasket is in the upper lefthand quadrant of the Sensor Base. The Sensor Base has an UP arrow molded into the surface in the same quadrant location (see Figure 6).

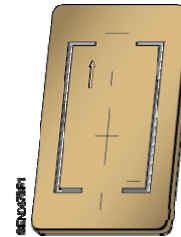
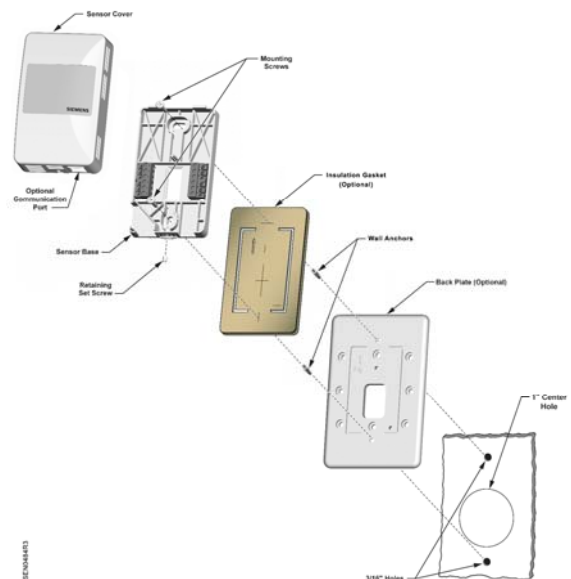

Figure 2. Insulating Gasket.

4. Pull about three inches (75 mm) of the cable through the hole in the base plate.
5. Mount the room unit base plate on the wall, noting the UP arrow:  
**NOTE:** If required, position the Back Plate behind the Room Unit Base, aligning the top and bottom mounting holes, prior to mounting to the wall:
  - a. Install the two mounting screws provided, but do not tighten.
  - b. Level the room unit base plate for appearance.
  - c. Tighten the two mounting screws to the room unit base plate.
6. Cut the cable, leaving about three inches (75 mm) on the room unit side of the drywall. Ensure that pin Number 1 connects to the same wire at each end of the cable.



**NOTE:** See Figure 2 for details on optional Gasket application.

Figure 3. Drywall Mounting (No Rough-in), Typical.

7. Terminate the wires to the termination blocks on the room unit's base plate. (See Figure 6.)
8. Feed the extra cable back through the hole.

### Sensor Set-up

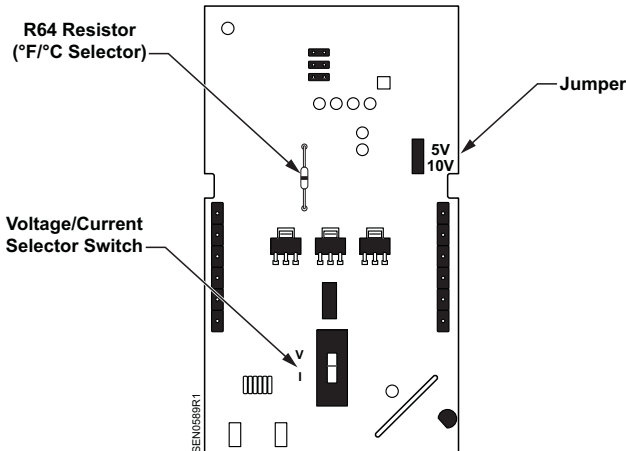

**Figure 4. Circuit Board**  
(Located inside Room Unit Cover.)

1. If the device has a switch, determine if voltage or current output is needed.
  - For current, set the switch in the down position (I).
  - For voltage, set the switch in the up position (V).

**NOTE:** The output setting applies to all outputs (humidity, temperature, and setpoint).
2. If selecting voltage, set the jumper:
  - Use the top and middle pins for 0-5V.
  - Use the bottom and middle pins for 0-10V.

**NOTE:** If the jumper is missing or removed, the output voltage will default to 0-10V.

**NOTE:** The factory default for displayed temperature units is °F. To change the display to °C, snip the wire jumper (0 Ohm resistor R64) on the back of the PCA.

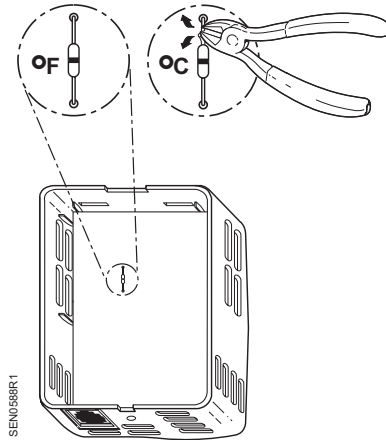

**Figure 5. Changing Display to °C.**

3. Snap the room unit cover to the room unit base plate by first hooking the room unit front to the top latches, and then rotating the cover downward until it latches.
4. Loosen the safety set screw at the bottom of the base one or two revolutions to lock the cover to the base. Be careful not to loosen too far as the screw can be completely removed from the base.

### Electrical Box and Rough-in Mounting, Typical

1. If a locator is attached to the rough-in device, remove the locator by removing the two screws and lightly rocking the locator to pull it free.
2. Untie the twist tie and pull about three inches (75 mm) of the room unit cable through the hole in the base plate.
3. Mount the room unit base plate on the wall, noting the UP arrow:
  - a. Install the two room unit mounting screws provided, but do not tighten.
  - b. Level the room unit base plate for appearance only.
  - c. Tighten the two mounting screws to the room unit base plate.



**CAUTION:**

Over-tightening may cause the room unit base plate to crack or bend.

4. Continue with *Drywall Mounting (No Rough-in), Typical*, Steps 6 through 8, and *Sensor Set-up*.



**CAUTION:**

To prevent equipment damage, do the following:

If room unit is powered by AC (See Figure 8.):

- AC Supply must be type NEC Class 2 and earth grounded at the secondary neutral.
- Room Unit ACN (GND) must be connected to the controller common.
- If the controller has a floating common, that common must be connected to the same earth ground point as the controller AC supply.

If room unit is powered by isolated DC (See Figure 7):

- Where power is current limited up to 300 mA, it is not required to earth ground the controller isolated common.
- Room Unit DC-(GND) must be connected to the controller common.



**CAUTION:**

Follow manufacturer's Installation Instructions and Wiring Guidelines for connecting the controller to the Room Unit.

- APOGEE Controllers with common already earth grounded are TXIO used on PXC Modular, PXC Compact 36 Expansion and P1 BIM or PTM used on MBC and RBC. These do not require the earth ground wire to be connected to the controller as shown in Figure 8.
- APOGEE Controllers with floating common are PXC Compact 16/24/36, MEC, PXM, LON TEC and PPM. These require the earth ground wire to be connected to the controller as shown in Figure 8.

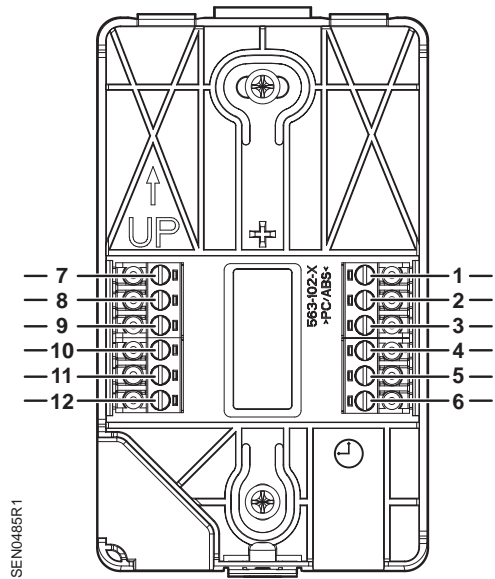

**Figure 6. Typical Wiring Base.**  
 (All terminals may not be present.)

Pin No.	Function
<b>QFA3212.EWSN or QFA32SS.EWSN</b>	
1	DC+ or ACH
2	DC- or ACN (GND)
3	Temp Output
4	Humidity Output
5*	Passive Temp
6*	Passive Temp Common
<b>QFA3212.FWSN or QFA32SS.FWSN</b>	
1	DC+ or ACH
2	DC- or ACN (GND)
3	Temp Output
4	Humidity Output
5*	Passive Temp
6*	Passive Temp Common
7	Setpoint Output
8	Override
9	Override Common

\* Not available on "SS" models.

**NOTE:** If active temperature (0-5V/0-10V/4-20 mA) (Pin 3) rather than passive/resistive temperature is used, Passive Temp Common (Pin 6) does not need to be terminated.

The installation is now complete.

**NOTE:**

Externally DC powered 2200 Room Units require isolated DC supply with all commons connected and may be used on the same controller with other Room Units powered by Internal Sensor Supply.

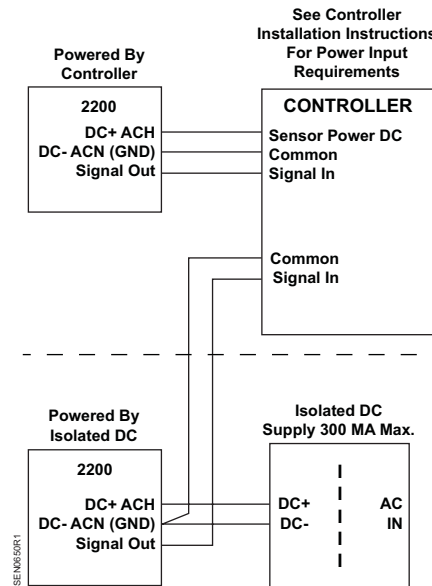

**Figure 7. Externally DC Powered 2200 Room Units.**

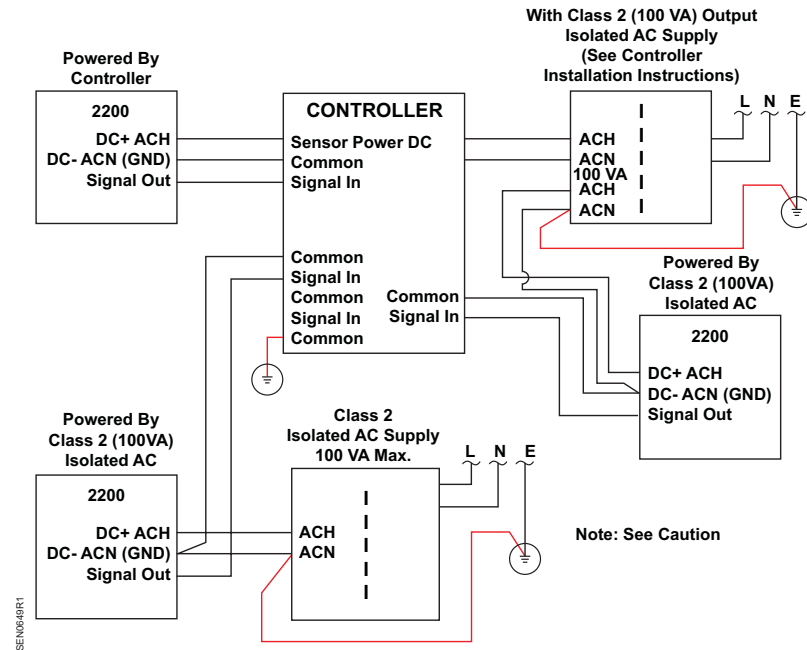

**NOTE:**

Externally AC powered 2200 Room Units require controller common and all AC secondary neutral and all AC secondary common to be earth grounded and may be used on the same controller with other room units powered by internal sensor supply.

**Figure 8. Externally AC Powered 2200 Room Units.**

Information in this publication is based on current specifications. The company reserves the right to make changes in specifications and models as design improvements are introduced. APOGEE is a registered trademark of Siemens Industry, Inc. Other product or company names mentioned herein may be the trademarks of their respective owners. © 2013 Siemens Industry, Inc.