

V-3000 Pneumatic Valve Actuator Exposed or Enclosed

The V-3000 Series Pneumatic Valve Actuators are designed to accurately position steam or water valve modulating plugs in response to a pneumatic signal from a controller. Two models of the V-3000 are available; the exposed model is for installation in a protected location and the enclosed model is for installation in a location where the actuator would be subjected to tampering. A V-9502 Valve Positioner can be ordered separately for use on the exposed model only in applications where sequential operation is desired or additional positioning power is necessary; refer to the Specifications Table for ordering information.

Construction

Both models of the V-3000 have a molded synthetic rubber diaphragm design. This molded diaphragm provides a constant effective area throughout the valve stem stroke. All parts are protected by a sturdy die cast aluminum housing. The actuator assembly can be removed or repositioned by loosening a single set screw without disturbing the rest of the valve assembly.

Operation

With no control air pressure applied to the diaphragm, the valve is in the normal position. Spring and fluid forces in the valve combine to balance against the diaphragm pressure. Reducing the air pressure permits the valve spring to return the valve plug to its normal position.

also be ordered factory mounted



Fig. 1: Exposed V-3000 Actuator



Fig. 2: Enclosed V-3000 Actuator

Mounting

Both the exposed and enclosed V-3000 Actuators are easily field mounted to the valve bonnet with a single set screw. The V-3000 Exposed Actuator can

to any of the V-3000 or V-4000 Series Valves (except V-3854). The V-9502 Valve Positioner can also be factory mounted on these units.

Specifications

Product	V-3000 Pneumatic Valve Actuator	
Models	V-3000-1	Exposed
	V-3000-2	Enclosed
Max Control Pressure	30 PSIG (70 kPa)	
Air Connection	1/8 in. NPT Barbed Fitting for 5/32 in. O.D. Poly tubing	
Ambient Operating Temperature Limits	-20 to 150°F (-29 to 66°C)	
Max Storage Temperature	150°F (66°C)	
Materials	Housing	Die Cast Aluminum with Enamel Finish
	Diaphragm	Synthetic Rubber
Accessories for Exposed Model Only (Order Separately)	V-3000-10 Valve Position Indicator V-9502-15 Valve Positioner	
Shipping Weight	V-3000-1	0.9 lb (.40 kg)
	V-3000-2	1.0 lb (.45 kg)

The performance specifications are nominal and conform to acceptable industry standards. For application at conditions beyond these specifications, consult the local Johnson Controls office. Johnson Controls, Inc. shall not be liable for damages resulting from misapplication or misuse of its products.

Dimensions in./mm

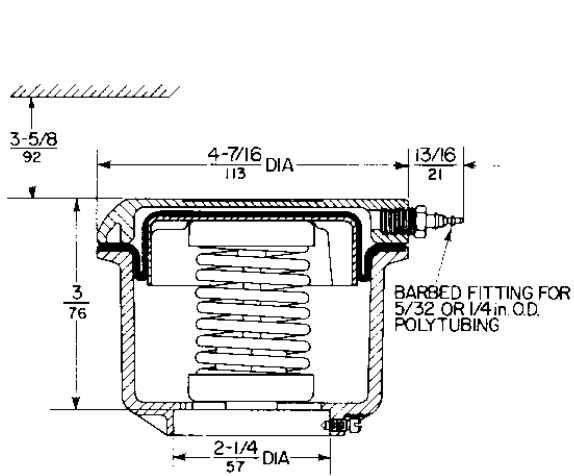

Fig. 3: Exposed V-3000 Actuator

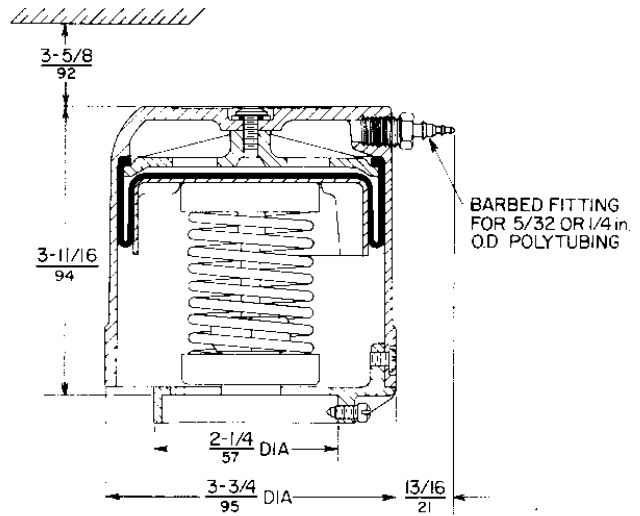

Fig. 4: Enclosed V-3000 Actuator

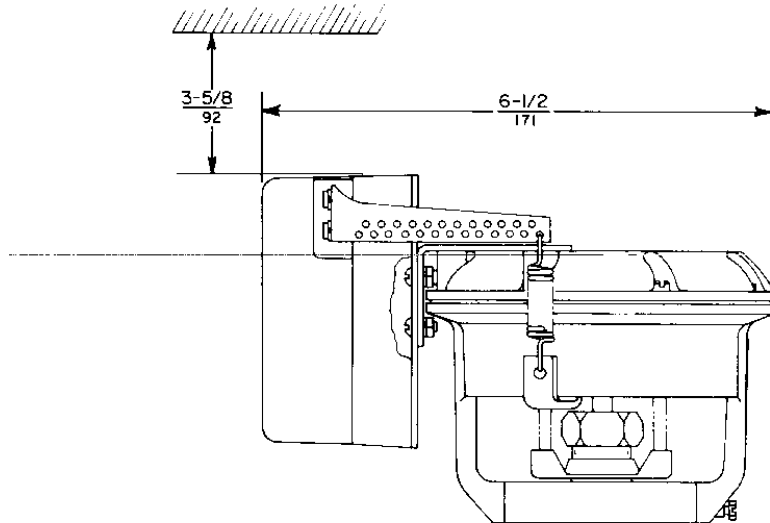

Fig. 5: Exposed V-3000 Actuator with V-9502 Valve Positioner

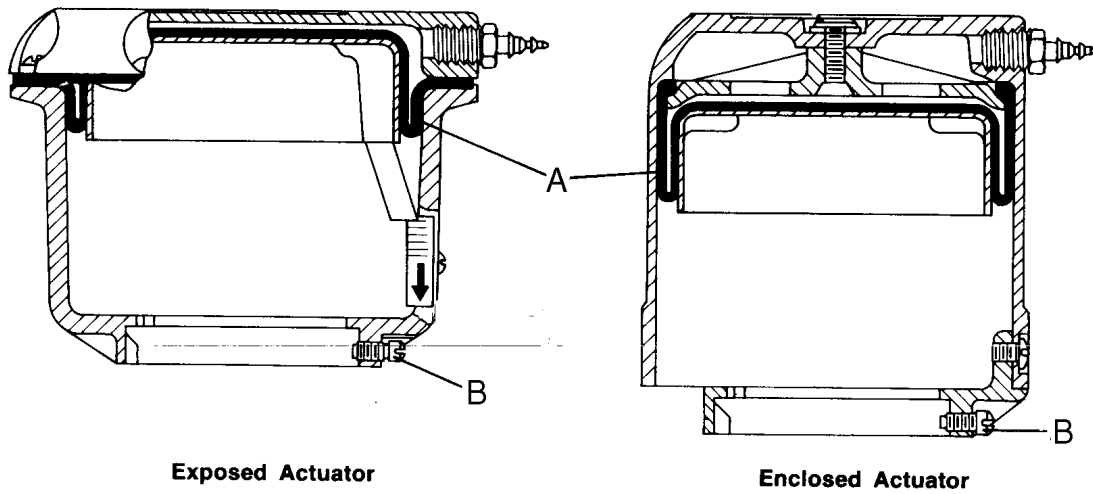

Fig. 6: V-3000 Series Pneumatic Valve Actuators

Table 1: Repair Parts

Item	Description	Shipping Weight lb.*	Code Number
A	Diaphragm:		
	For Exposed Actuator	.06	V-3000-600
	For Enclosed Actuator	.09	V-3000-601
B	Set Screw	.01	V-3100-643

*lb. x 0.454 = kg

Notes

JOHNSON
CONTROLS

Controls Group
507 E. Michigan Street
P.O. Box 423
Milwaukee, WI 53202

Printed in U.S.A.