

A MechTronics Controls Company
www.hvacusa.com
 Phone (877) 632-4876

Minimum 90 in-lb Torque

- For damper areas up to 22 sq-ft*

Applications

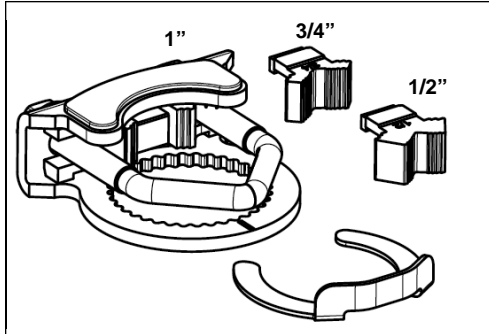

New standard clamp fits standard 1/2" shafts to 1.05" jackshafts.

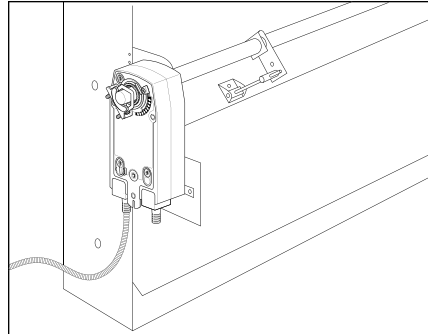

Mount directly to 1.05" jackshafts.

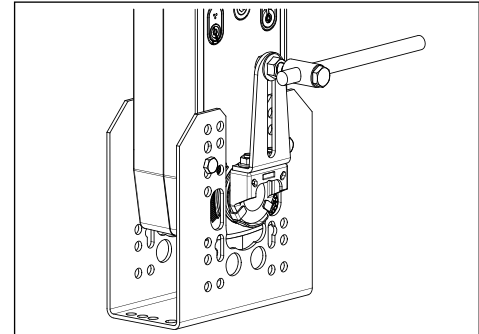

Linkage solutions are available when direct coupling is not possible.

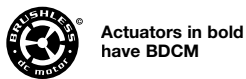

Actuators in bold have BDCM

NFB, NFX Series - At A Glance

	NFB24, NFX24 (p. 105)	NFB24 N4(H), NFX24 N4 (p. 107)	NFB24-S, NFX24-S (p. 105)	NFB24-S N4(H), NFX24-S N4 (p. 107)	NFBUP, NFXUP (p. 109)	NFBUP N4(H), NFXUP N4 (p. 111)	NFBUP-S, NFXUP-S (p. 109)	NFBUP-S N4(H), NFXUP-S N4 (p. 111)	NFB24-SR, NFX24-SR (p. 113)	NFB24-SR N4(H), NFX24-SR N4 (p. 115)	NFB24-SR-S, NFX24-SR-S (p. 113)	NFB24-SR-S N4(H), NFX24-SR-S N4 (p. 115)	NFB24-MFT, NFX24-MFT (p. 117)	NFB24-MFT N4(H), NFX24-MFT N4 (p. 119)	NFB24-MFT-S, NFX24-MFT-S (p. 117)	NFB24-MFT-S N4(H), NFX24-MFT-S N4 (p. 119)
Torque:	90 in-lb	●	●	●	●	●	●	●	●	●	●	●	●	●	●	●
Power supply:	24 VAC/DC	●	●	●	●	●	●	●	●	●	●	●	●	●	●	●
	120 VAC				●	●	●	●								
	230 VAC								●	●	●	●				
Control signal:	On/Off	●	●	●	●	●	●	●								
	Proportional 2 to 10 VDC										●	●				
	Multi-function**												●	●	●	●
Feedback signal:	2 to 10 VDC										●	●				
	VDC variable**												●	●	●	●
Running time motor:	<75 seconds	●	●	●	●	●	●	●								
	95 seconds constant								●	●	●	●				
	Adj. 40 to 220 seconds***												●	●	●	●
	spring: <20 seconds	●	●	●	●	●	●	●	●	●	●	●	●	●	●	●
Brushless DC Motor									●	●	●	●	●	●	●	●
External direction of rotation switch									●	●	●	●	●	●	●	●
Manual override	●	●	●	●	●	●	●	●	●	●	●	●	●	●	●	●
Appliance rated cable, 18 GA (default)	●	●	●	●	●	●	●	●	●	●	●	●	●	●	●	●
Plenum rated cable, 18 GA (optional)	●								●				●			
Built-in auxiliary switch, Two SPDT			●	●			●	●			●	●			●	●
NEMA 4 rated housing		●				●				●		●		●		●
Installation instructions.....(p. 121-127)																
General wiring.....(p. 129)																
Start-up and checkout.....(p. 130)																
Electrical operations.....(p. 128)																

*Based on 4 in-lb/ft² damper torque loading. Parallel blade. No edge seals. **Default 2 to 10 VDC. ***Default 150 seconds.

A CLOSER LOOK...

- Cut labor costs with simple direct coupling.
- True mechanical spring return – the most reliable fail-safe.
- Mount for clockwise or counterclockwise fail-safe.
- Check damper position easily with clear position indicator.
- Don't worry about actuator burn-out. Belimo is overload-proof throughout rotation.
- Built-in mechanical stop to adjust angle of rotation.
- Manual override crank speeds installation
- Need to change control direction? Do it easily with a simple switch (modulating actuators).
- Incorporated breather membrane optimizes performance in harsh airstream environments.
- Built-in auxiliary switches are easy to use, offers feedback or signal for additional device (-S models).
- Microprocessor-controlled brushless DC motor increases actuator life span and reliability, provides constant running time (modulating actuators).
- Rugged metal on plastic housing withstands rough handling in the mechanical room.
- Standard 3 ft. appliance rated cable and conduit connector eases installation.
- Added flexibility to select clamp, electrical connection, and running time to fit your specific application with Belimo's customized line of actuators (NFX).



The Belimo Difference

- **Customer Commitment.**
Extensive product range. Application assistance.
Same-day shipments. Free technical support. Five year warranty.
- **Low Installation and Life-Cycle Cost.**
Easy installation. Accuracy and repeatability.
Low power consumption. No maintenance.
- **Long Service Life.**
Components tested before assembly. Every product tested before shipment.
30+ years direct coupled actuator design.



M40103 - 09/11 - Subject to change. © Belimo Aircontrols (USA), Inc.

NFB24, NFB24-S, NFX24, NFX24-S

On/Off, Spring Return, 24 V



- Torque min. 90 in-lb, for control of air dampers

Application

For On/Off, fail-safe control of dampers in HVAC systems. Actuator sizing should be done in accordance with the damper manufacturer's specifications. Control is On/Off from an auxiliary contact, or a manual switch.

The actuator is mounted directly to a damper shaft up to 1.05" in diameter by means of its universal clamp. A crank arm and several mounting brackets are available for applications where the actuator cannot be direct coupled to the damper shaft.

Operation

The NFB and NFX series actuators provide true spring return operation for reliable fail-safe application and positive close off on air tight dampers. The spring return system provides constant torque to the damper with, and without, power applied to the actuator.

The NFB and NFX series provides 95° of rotation and is provided with a graduated position indicator showing 0° to 95°.

The actuator may be stalled anywhere in its normal rotation without the need of mechanical end switches.

The NFB24-S and NFX24-S versions are provided with two built-in auxiliary switches. These SPDT switches are provided for safety interfacing or signaling, for example, for fan start-up. The switching function at the fail-safe position is fixed at +10°, the other switch function is adjustable between +10° to +90°. The NFB24, NFB24-S, NFX24 and NFX24-S actuator is shipped at +5° (5° from full fail-safe) to provide automatic compression against damper gaskets for tight shut-off.

Technical Data		NFB24, NFB24-S, NFX24, NFX24-S
Power supply		24 VAC ± 20% 50/60 Hz 24 VDC +20% / -10%
Power consumption	running	6 W
	holding	2.5 W
Transformer sizing		8.5 VA (class 2 power source)
Electrical connection	NFB24...	3 ft, 18 GA appliance cable, 1/2" conduit connector -S models: two 3 ft, 18 gauge appliance cables with 1/2" conduit connectors
	NFX24...	3 ft [1m], 10 ft [3m] or 16 ft [5m] 18 GA appliance or plenum cables, with or without 1/2" conduit connector -S models: two 3 ft [1m], 10 ft [3m] or 16 ft [5m] appliance cables, with or without 1/2" conduit connectors
Overload protection		electronic throughout 0 to 95° rotation
Control		on/off
Torque		90 in-lb [10 Nm] minimum
Direction of rotation	spring	reversible with CW/CCW mounting
Mechanical angle of rotation		95° (adjustable with mechanical end stop, 35° to 95°)
Running time	motor	< 75 seconds
	spring	20 seconds @ -4°F to 122°F [-20°C to 50°C]; < 60 seconds @ -22°F [-30°C]
Position indication		visual indicator, 0° to 95° (0° is full spring return position)
Manual override		5 mm hex crank (3/16" Allen), supplied
Humidity		max. 95% RH non-condensing
Ambient temperature		-22°F to 122°F [-30°C to 50°C]
Storage temperature		-40°F to 176°F [-40°C to 80°C]
Housing		Nema 2, IP54, Enclosure Type2
Housing material		zinc coated metal and plastic casing
Agency listings †		cULus acc. to UL60730-1A/-2-14, CAN/CSA E60730-1:02, CE acc. to 2004/108/EC & 2006/95/EC
Noise level		<50dB(A) motor @ 75 seconds <62dB(A) spring return
Servicing		maintenance free
Quality standard		ISO 9001
Weight		4.15 lbs (1.9 kg); 4.4 lbs (2.0 kg) with switches
† Rated Impulse Voltage 800V, Type of action 1.AA (1.AA.B for -S version), Control Pollution Degree 3.		
NFB24-S, NFX24-S		
Auxiliary switches		2 x SPDT 3A (0.5A) @ 250 VAC, UL approved one set at +10°, one adjustable 10° to 90°

Dimensions (Inches [mm])

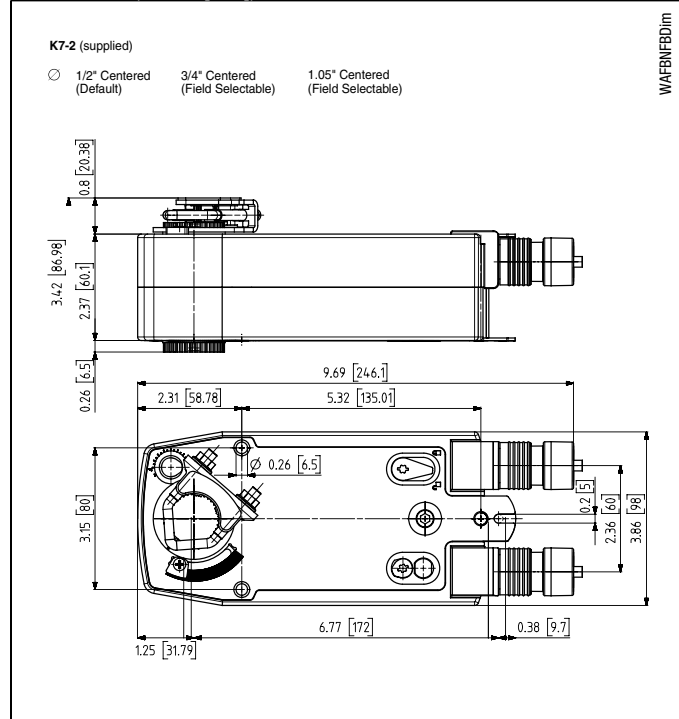

M40103 - 09/11 - Subject to change. © Belimo Aircontrols (USA), Inc.

Accessories

AV 8-25	Shaft extension
IND-AFB	Damper position indicator
KH-AFB	Crank arm
K7-2	Universal clamp for up to 1.05" dia jackshafts
TF-CC US	Conduit fitting
Tool-06	8mm and 10 mm wrench
ZG-100	Universal mounting bracket
ZG-101	Universal mounting bracket
ZG-118	Mounting bracket for Barber Colman® MA 3../4.., Honeywell® Mod III or IV or Johnson® Series 100 replacement or new crank arm type installations
ZG-AFB	Crank arm adaptor kit
ZG-AFB118	Crank arm adaptor kit
ZS-100	Weather shield (metal)
ZS-150	Weather shield (polycarbonate)
ZS-260	Explosion-proof housing
ZS-300	NEMA 4X housing

Note: When using NFB24, NFB24-S, NFX24, NFX24-S actuators, only use accessories listed on this page.

For actuator wiring information and diagrams, refer to Belimo Wiring Guide.

Typical Specification

On/Off spring return damper actuators shall be direct coupled type which require no crank arm and linkage and be capable of direct mounting to a jackshaft up to a 1.05" diameter. The actuators must be designed so that they may be used for either clockwise or counterclockwise fail-safe operation. Actuators shall be protected from overload at all angles of rotation. If required, two SPDT auxiliary switch shall be provided having the capability of one being adjustable. Actuators with auxiliary switches must be constructed to meet the requirements for Double Insulation so an electrical ground is not required to meet agency listings. Actuators shall be cULus Approved and have a 5 year warranty, and be manufactured under ISO 9001 International Quality Control Standards. Actuators shall be as manufactured by Belimo.

Wiring Diagrams
INSTALLATION NOTES

- 1 Provide overload protection and disconnect as required.
- 2 **CAUTION Equipment Damage!**
Actuators may be connected in parallel.
Power consumption and input impedance must be observed.
- 3 Actuators may also be powered by 24 VDC.
- 4 For end position indication, interlock control, fan startup, etc., NFB24-S and NFX24-S incorporates two built-in auxiliary switches: 2 x SPDT, 3A (0.5A) @250 VAC, UL Approved, one switch is fixed at +10°, one is adjustable 10° to 90°.

APPLICATION NOTES

- ◆ Meets cULus requirements without the need of an electrical ground connection.

WARNING Live Electrical Components!

During installation, testing, servicing and troubleshooting of this product, it may be necessary to work with live electrical components. Have a qualified licensed electrician or other individual who has been properly trained in handling live electrical components perform these tasks. Failure to follow all electrical safety precautions when exposed to live electrical components could result in death or serious injury.

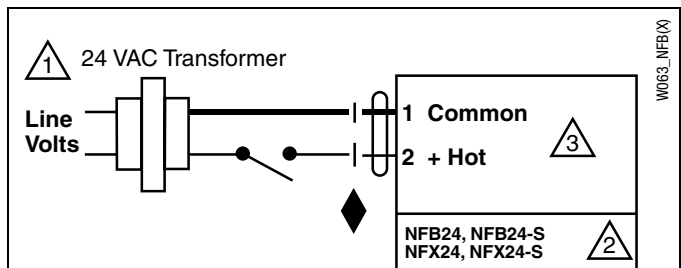
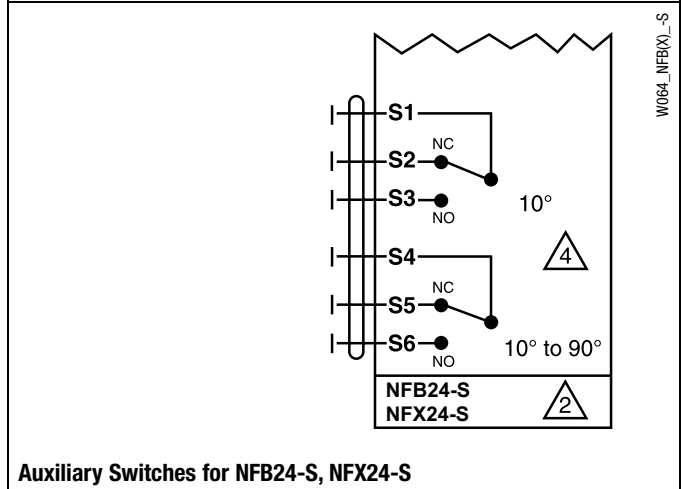
On/Off wiring for NFB24, NFX24

Auxiliary Switches for NFB24-S, NFX24-S

NFB24 N4(H), NFB24-S N4(H), NFX24 N4, NFX24-S N4

NEMA 4, On/Off, Spring Return, 24 V



Technical Data		NFB24 N4(H), NFB24-S N4(H), NFX24 N4, NFX24-S N4
Power supply		24 VAC ± 20% 50/60 Hz 24 VDC +20% / -10%
Power consumption	running	6 W / heater 25 W
	holding	2.5 W
Transformer sizing		8.5 VA (class 2 power source) / heater 25 VA
Electrical connection		3 ft, 18 GA appliance cable, 1/2" conduit connector
	NFB... N4	-S models: two 3 ft, 18 gauge appliance cables with 1/2" conduit connectors
	heater (N4H)	terminal block, 26-16 GA
	NFX... N4	3 ft [1m], 10 ft [3m] or 16 ft [5m] 18 GA appliance or plenum cables, with 1/2" conduit connector
		-S models: Two 3 ft [1m], 10 ft [3m] or 16 ft [5m] appliance cables with 1/2" conduit connectors
Overload protection		electronic throughout 0 to 95° rotation
Control		on/off
Torque		90 in-lb [10 Nm] minimum
Direction of rotation	spring	reversible with CW/CCW mounting inside housing
Mechanical angle of rotation		95° (adjustable with mechanical end stop, 35° to 95°)
Running time	motor	< 75 seconds
	spring	20 seconds @ -4°F to 122°F [-20°C to 50°C]; < 60 seconds @ -22°F [-30°C]
	spring (with heater)	20 seconds @ -4°F to 122°F [-20°C to 50°C]; < 60 seconds @ -49°F [-45°C]
Position indication		visual indicator, 0° to 95° (0° is full spring return position)
Manual override		5 mm hex crank (3/16" Allen), supplied
Humidity		max. 95% RH non-condensing
Ambient temperature		-22°F to 122°F [-30°C to 50°C]
	with heater	-49°F to 122°F [-45°C to 50°C]
Storage temperature		-40°F to 176°F [-40°C to 80°C]
Housing		UL Type 4, NEMA 4, IP66
Housing material		polycarbonate
Agency listings †		cULus acc. to UL60730-1A/-2-14, CAN/CSA E60730-1:02, CE acc. to 2004/108/EC & 2006/95/EC
Noise level		<50dB(A) motor @ 75 seconds ≤62dB(A) spring return
Servicing		maintenance free
Quality standard		ISO 9001
Weight		9.25 lbs (4.2 kg); 9.5 lbs (4.3 kg) with switches 10 lbs (4.5 kg) with heater
† Rated Impulse Voltage 800V, Type of action 1.AA (1.AA.B for -S version), Control Pollution Degree 4.		
NFB24-S N4(H), NFX24-S N4		
Auxiliary switches		2 x SPDT 3A (0.5A) @ 250 VAC, UL approved one set at +10°, one adjustable 10° to 90°

- Torque min. 90 in-lb, for control of air dampers

Application

For On/Off, fail-safe control of dampers in HVAC systems. Actuator sizing should be done in accordance with the damper manufacturer's specifications. Control is On/Off from an auxiliary contact, or a manual switch.

The actuator is mounted directly to a damper shaft up to 1.05" in diameter by means of its universal clamp. A crank arm and several mounting brackets are available for applications where the actuator cannot be direct coupled to the damper shaft.

Operation

The NFB N4(H), NFX N4 series actuators provide true spring return operation for reliable fail-safe application and positive close off on air tight dampers. The spring return system provides constant torque to the damper with, and without, power applied to the actuator.

The NFB N4(H), NFX N4 series provides 95° of rotation and is provided with a graduated position indicator showing 0° to 95°.

The actuator may be stalled anywhere in its normal rotation without the need of mechanical end switches.

The NFB24-S N4(H), NFX24-S N4 version are provided with two built-in auxiliary switches. These SPDT switches are provided for safety interfacing or signaling, for example, for fan start-up. The switching function at the fail-safe position is fixed at +10°, the other switch function is adjustable between +10° to +90°.

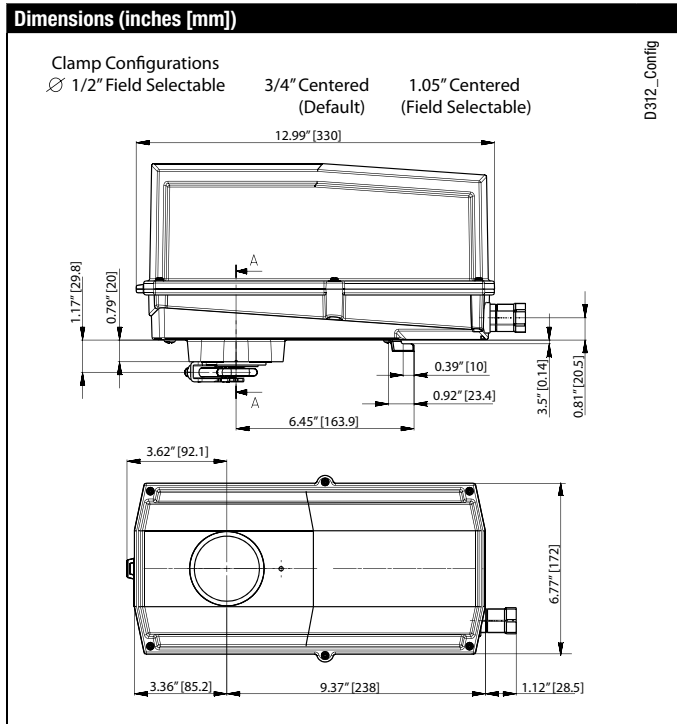

M40103 - 09/11 - Subject to change. © Belimo Aircontrols (USA), Inc.

Accessories

Tool-06	8mm and 10 mm wrench
43442-00001	Gland (needed for additional wires)
11097-00001	Gasket for Gland (needed for additional wires)

NOTE: When using NFB24 N4(H), NFB24-S N4(H), NFX24 N4, NFX24-S N4 actuators, only use accessories listed on this page.
For actuator wiring information and diagrams, refer to Belimo Wiring Guide.

Typical Specification

On/Off spring return damper actuators shall be direct coupled type which require no crank arm and linkage and be capable of direct mounting to a jackshaft up to a 1.05" diameter. The actuators must be designed so that they may be used for either clockwise or counterclockwise fail-safe operation. Actuators shall be protected from overload at all angles of rotation. If required, two SPDT auxiliary switch shall be provided having the capability of one being adjustable. Actuators with auxiliary switches must be constructed to meet the requirements for Double Insulation so an electrical ground is not required to meet agency listings. Actuators shall be cULus Approved and have a 5 year warranty, and be manufactured under ISO 9001 International Quality Control Standards. Actuators shall be as manufactured by Belimo.

Wiring Diagrams
INSTALLATION NOTES

- 1 Provide overload protection and disconnect as required.
- 2 **CAUTION Equipment Damage!**
Actuators may be connected in parallel.
Power consumption and input impedance must be observed.
- 3 Actuators may also be powered by 24 VDC.
- 4 For end position indication, interlock control, fan startup, etc., NFB24-S N4(H), NFX24-S N4 incorporates two built-in auxiliary switches: 2 x SPDT, 3A (0.5A) @250 VAC, UL Approved, one switch is fixed at +10°, one is adjustable 10° to 90°.

APPLICATION NOTES

- ◆ Meets cULus requirements without the need of an electrical ground connection.

WARNING Live Electrical Components!

During installation, testing, servicing and troubleshooting of this product, it may be necessary to work with live electrical components. Have a qualified licensed electrician or other individual who has been properly trained in handling live electrical components perform these tasks. Failure to follow all electrical safety precautions when exposed to live electrical components could result in death or serious injury.

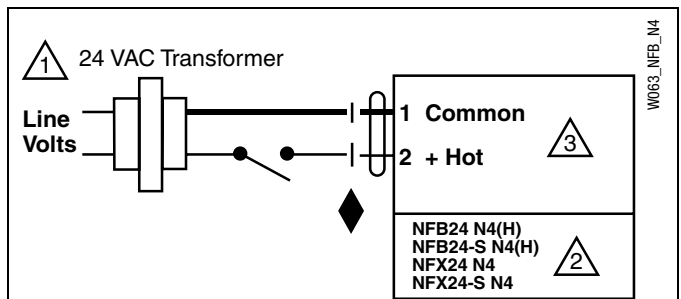
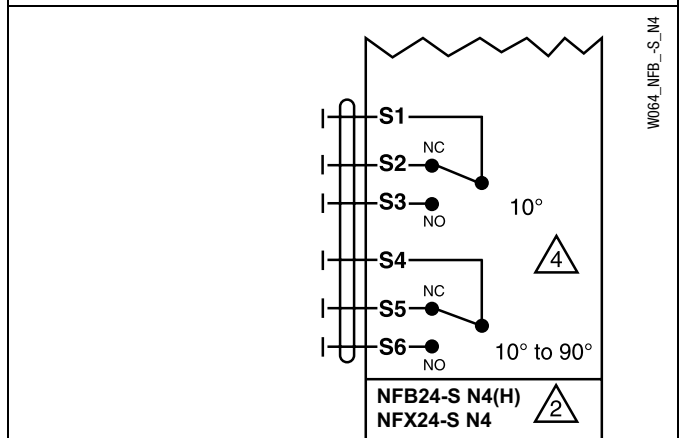
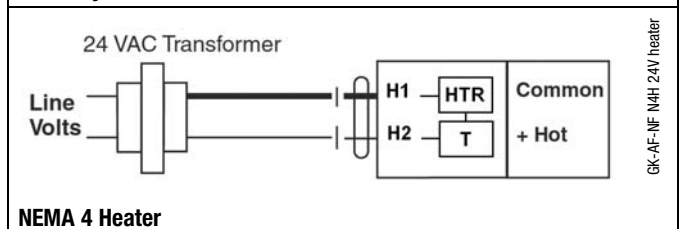
On/Off Wiring

Auxiliary Switches

NEMA 4 Heater

NFBUP, NFBUP-S, NFXUP, NFXUP-S

On/Off, Spring Return, 24 to 240 VAC



Technical Data		NFBUP, NFBUP-S, NFXUP, NFXUP-S
Power supply		24...240 VAC -20% / +10%, 50/60 Hz 24...125 VDC ±10%
Power consumption	running	6 W
	holding	2.5 W
Transformer sizing		6 VA @ 24 VAC (class 2 power source) 6.5 VA @ 120 VAC 9.5 VA @ 240 VAC
Electrical connection		
	NFBUP...	3 ft, 18 GA appliance cable, 1/2" conduit connector -S models: Two 3 ft, 18 gauge appliance cables with 1/2" conduit connectors
	NFXUP...	3 ft [1m], 10 ft [3m] or 16 ft [5m] 18 GA appliance cable, with or without 1/2" conduit connector -S models: two 3 ft [1m], 10 ft [3m] or 16 ft [5m] appliance cables with or without 1/2" conduit connectors
Overload protection		electronic throughout 0 to 95° rotation
Control		on/off
Torque		90 in-lb [10 Nm] minimum
Direction of rotation	spring	reversible with CW/CCW mounting
Mechanical angle of rotation		95° (adjustable with mechanical end stop, 35° to 95°)
Running time	motor	< 75 seconds
	spring	20 seconds @ -4°F to 122°F [-20°C to 50°C]; < 60 seconds @ -22°F [-30°C]
Position indication		visual indicator, 0° to 95° (0° is full spring return position)
Manual override		5 mm hex crank (3/16" Allen), supplied
Humidity		max. 95% RH non-condensing
Ambient temperature		-22°F to 122°F [-30°C to 50°C]
Storage temperature		-40°F to 176°F [-40°C to 80°C]
Housing		Nema 2, IP54, Enclosure Type2
Housing material		zinc coated metal and plastic casing
Agency listings †		cULus acc. to UL60730-1A/-2-14, CAN/CSA E60730-1:02, CE acc. to 2004/108/EC & 2006/95/EC
Noise level		<50dB(A) motor @ 75 seconds ≤62dB(A) spring return
Servicing		maintenance free
Quality standard		ISO 9001
Weight		4.15 lbs (1.9 kg), 4.4 lbs (2.0 kg) with switches
† Rated Impulse Voltage 4kV, Type of action 1.AA (1.AA.B for -S version), Control Pollution Degree 3.		
NFBUP-S, NFXUP-S		
Auxiliary switches		2 x SPDT 3A (0.5A) @ 250 VAC, UL approved one set at +10°, one adjustable 10° to 90°

Torque min. 90 in-lb, for control of air dampers

Application

For On/Off, fail-safe control of dampers in HVAC systems. Actuator sizing should be done in accordance with the damper manufacturer's specifications. Control is On/Off from an auxiliary contact, or a manual switch.

The actuator is mounted directly to a damper shaft up to 1.05" in diameter by means of its universal clamp. A crank arm and several mounting brackets are available for applications where the actuator cannot be direct coupled to the damper shaft.

Operation

The NFB and NFX series actuators provide true spring return operation for reliable fail-safe application and positive close off on air tight dampers. The spring return system provides constant torque to the damper with, and without, power applied to the actuator.

The NFB and NFX series provides 95° of rotation and is provided with a graduated position indicator showing 0° to 95°.

The actuator may be stalled anywhere in its normal rotation without the need of mechanical end switches.

The NFBUP-S and NFXUP-S versions are provided with two built-in auxiliary switches. These SPDT switches provide safety interfacing or signaling, for example, for fan start-up. The switching function at the fail-safe position is fixed at +10°, the other switch function is adjustable between +10° to +90°. The NFBUP, NFBUP-S, NFXUP and NFXUP-S actuator is shipped at +5° (5° from full fail-safe) to provide automatic compression against damper gaskets for tight shut-off.

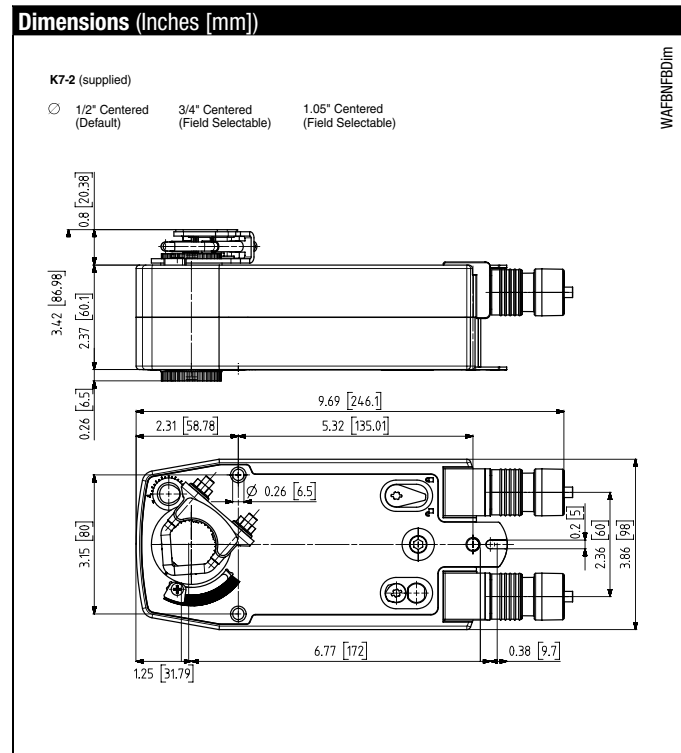

M40103 - 09/11 - Subject to change. © Belimo Aircontrols (USA), Inc.

Accessories

AV 8-25	Shaft extension
IND-AFB	Damper position indicator
K7-2	Universal clamp for up to 1.05" dia jackshafts
KH-AFB	Crank arm
TF-CC US	Conduit fitting
Tool-06	8mm and 10 mm wrench
ZG-100	Universal mounting bracket
ZG-101	Universal mounting bracket
ZG-118	Mounting bracket for Barber Colman® MA 3../4.., Honeywell® Mod III or IV or Johnson® Series 100 replacement or new crank arm type installations
ZG-AFB	Crank arm adaptor kit
ZG-AFB118	Crank arm adaptor kit
ZS-100	Weather shield (metal)
ZS-150	Weather shield (polycarbonate)
ZS-260	Explosion-proof housing
ZS-300	NEMA 4X housing

Note: When using NFBUP, NFBUP-S, NFXUP, NFXUP-S actuators, only use accessories listed on this page.

For actuator wiring information and diagrams, refer to Belimo Wiring Guide.

Typical Specification

On/Off spring return damper actuators shall be direct coupled type which require no crank arm and linkage and be capable of direct mounting to a jackshaft up to a 1.05" diameter. The actuators must be designed so that they may be used for either clockwise or counterclockwise fail-safe operation. Actuators shall be protected from overload at all angles of rotation. If required, two SPDT auxiliary switch shall be provided having the capability of one being adjustable. Actuators with auxiliary switches must be constructed to meet the requirements for Double Insulation so an electrical ground is not required to meet agency listings. Actuators shall be cULus Approved and have a 5 year warranty, and be manufactured under ISO 9001 International Quality Control Standards. Actuators shall be as manufactured by Belimo.

Wiring Diagrams
INSTALLATION NOTES

- 1 Provide overload protection and disconnect as required.
- 2 **CAUTION Equipment Damage!**
Actuators may be connected in parallel.
Power consumption and input impedance must be observed.
- 3 No ground connection is required.
- 4 For end position indication, interlock control, fan startup, etc., NFBUP-S and NFXUP-S incorporates two built-in auxiliary switches: 2 x SPDT, 3A (0.5A) @250 VAC, UL Approved, one switch is fixed at +10°, one is adjustable 10° to 90°.

APPLICATION NOTES

- ◆ Meets cULus requirements without the need of an electrical ground connection.

WARNING Live Electrical Components!

During installation, testing, servicing and troubleshooting of this product, it may be necessary to work with live electrical components. Have a qualified licensed electrician or other individual who has been properly trained in handling live electrical components perform these tasks. Failure to follow all electrical safety precautions when exposed to live electrical components could result in death or serious injury.

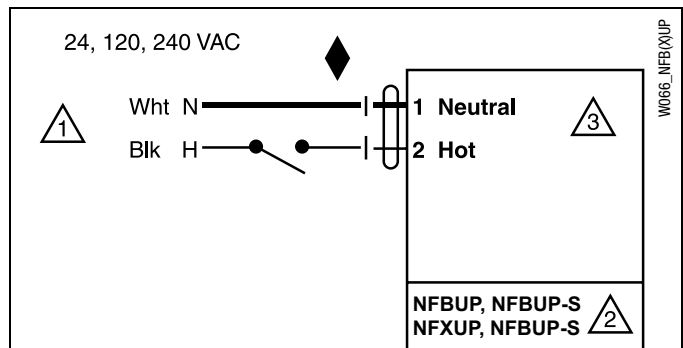
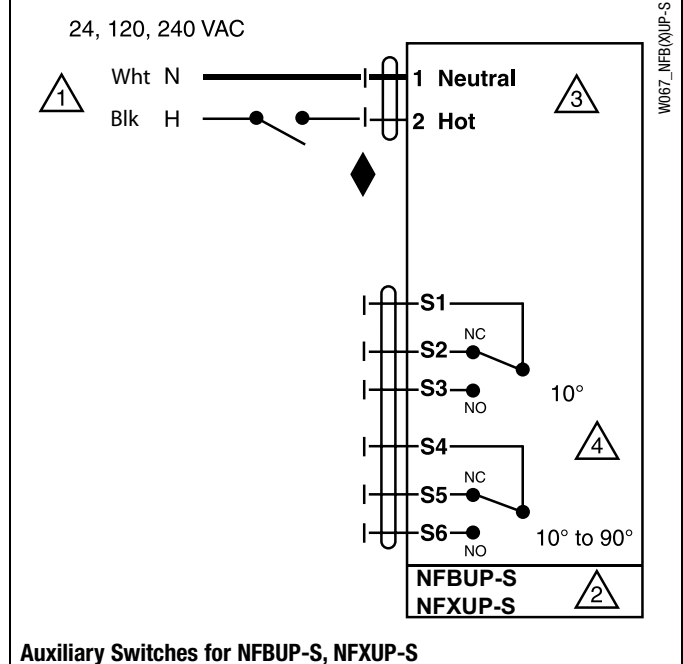
On/Off wiring for NFBUP, NFXUP

Auxiliary Switches for NFBUP-S, NFXUP-S

NFBUP N4(H), NFBUP-S N4(H), NFXUP N4, NFXUP-S N4

NEMA 4, On/Off, Spring Return, 24 to 240 VAC



Technical Data		NFBUP N4(H), NFBUP-S N4(H), NFXUP N4, NFXUP-S N4
Power supply		24...240 VAC -20% / +10%, 50/60 Hz 24...125 VDC ±10%
Power consumption	running holding	6 W / heater 25 W 2.5 W
Transformer sizing		6 VA @ 24 VAC (class 2 power source) 6.5 VA @ 120 VAC / heater 25 VA @ 120 VAC 9.5 VA @ 240 VAC
Electrical connection	NFBUP... N4	3 ft, 18 GA appliance cable, 1/2" conduit connector -S models: Two 3 ft, 18 gauge appliance cables with 1/2" conduit connectors
	heater (N4H)	terminal block, 18-16 GA
	NFXUP... N4	3 ft [1m], 10 ft [3m] or 16 ft [5m] 18 GA appliance cable, with or without 1/2" conduit connector -S models: two 3 ft [1m], 10 ft [3m] or 16 ft [5m] appliance cables with or without 1/2" conduit connectors
Overload protection		electronic throughout 0 to 95° rotation
Control		on/off
Torque		90 in-lb [10 Nm] minimum
Direction of rotation	spring	reversible with CW/CCW mounting inside housing
Mechanical angle of rotation		95° (adjustable with mechanical end stop, 35° to 95°)
Running time	motor spring	< 75 seconds 20 seconds @ -4°F to 122°F [-20°C to 50°C]; < 60 seconds @ -22°F [-30°C]
	spring (with heater)	20 seconds @ -4°F to 122°F [-20°C to 50°C]; < 60 seconds @ -49°F [-45°C]
Position indication		visual indicator, 0° to 95° (0° is full spring return position)
Manual override		5 mm hex crank (3/16" Allen), supplied
Humidity		max. 95% RH non-condensing
Ambient temperature		-22°F to 122°F [-30°C to 50°C]
	with heater	-49°F to 122°F [-45°C to 50°C]
Storage temperature		-40°F to 176°F [-40°C to 80°C]
Housing		UL Type 4, NEMA 4, IP66
Housing material		polycarbonate
Agency listings †		cULus acc. to UL60730-1A/-2-14, CAN/CSA E60730-1:02, CE acc. to 2004/108/EC & 2006/95/EC
Noise level		<50dB(A) motor @ 75 seconds <62dB(A) spring return
Servicing		maintenance free
Quality standard		ISO 9001
Weight		9.25 lbs (4.2 kg), 9.5 lbs (4.3 kg) with switches 10 lbs (4.5 kg) with heater
† Rated Impulse Voltage 4kV, Type of action 1.AA (1.AA.B for -S version), Control Pollution Degree 4.		
NFBUP-S N4(H), NFXUP-S N4		
Auxiliary switches		2 x SPDT 3A (0.5A) @ 250 VAC, UL approved one set at +10°, one adjustable 10° to 90°

Torque min. 90 in-lb, for control of air dampers

Application

For On/Off, fail-safe control of dampers in HVAC systems. Actuator sizing should be done in accordance with the damper manufacturer's specifications. Control is On/Off from an auxiliary contact, or a manual switch.

The actuator is mounted directly to a damper shaft up to 1.05" in diameter by means of its universal clamp. A crank arm and several mounting brackets are available for applications where the actuator cannot be direct coupled to the damper shaft.

Operation

The NFB N4(H), NFX N4 series actuators provide true spring return operation for reliable fail-safe application and positive close off on air tight dampers. The spring return system provides constant torque to the damper with, and without, power applied to the actuator.

The NFB N4(H), NFX N4 series provides 95° of rotation and is provided with a graduated position indicator showing 0° to 95°.

The actuator may be stalled anywhere in its normal rotation without the need of mechanical end switches.

The NFBUP-S N4(H), NFXUP-S N4 version are provided with two built-in auxiliary switches. These SPDT switches provide safety interfacing or signaling, for example, for fan start-up. The switching function at the fail-safe position is fixed at +10°, the other switch function is adjustable between +10° to +90°.

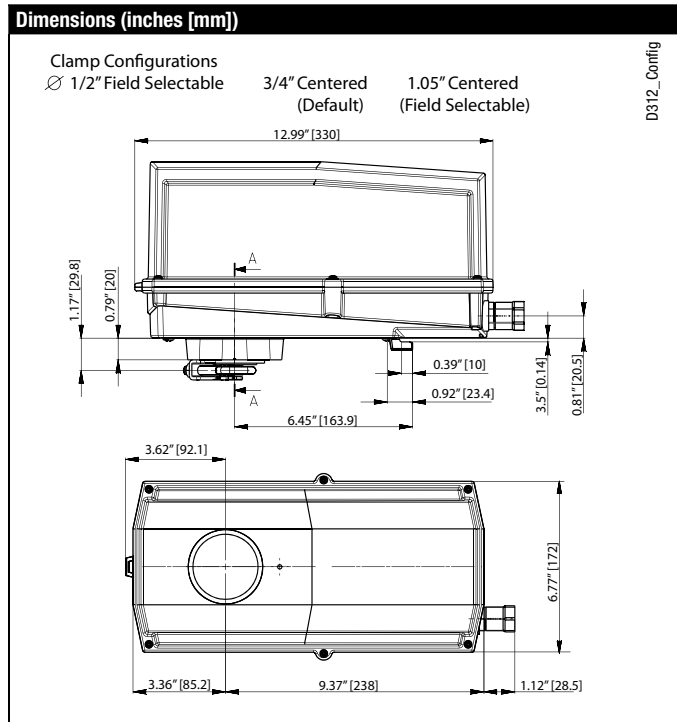

M40103 - 09/11 - Subject to change. © Belimo Aircontrols (USA), Inc.

Accessories

Tool-06	8mm and 10 mm wrench
43442-00001	Gland (needed for additional wires)
11097-00001	Gasket for Gland (needed for additional wires)

NOTE: When using NFBUP N4(H), NFBUP-S N4(H), NFXUP N4, NFXUP-S N4 actuators, only use accessories listed on this page.

For actuator wiring information and diagrams, refer to Belimo Wiring Guide.

Typical Specification

On/Off spring return damper actuators shall be direct coupled type which require no crank arm and linkage and be capable of direct mounting to a jackshaft up to a 1.05" diameter. The actuators must be designed so that they may be used for either clockwise or counterclockwise fail-safe operation. Actuators shall be protected from overload at all angles of rotation. If required, two SPDT auxiliary switch shall be provided having the capability of one being adjustable. Actuators with auxiliary switches must be constructed to meet the requirements for Double Insulation so an electrical ground is not required to meet agency listings. Actuators shall be cULus Approved and have a 5 year warranty, and be manufactured under ISO 9001 International Quality Control Standards. Actuators shall be as manufactured by Belimo.

Wiring Diagrams
INSTALLATION NOTES

1 Provide overload protection and disconnect as required.

2 CAUTION Equipment Damage!
Actuators may be connected in parallel.
Power consumption and input impedance must be observed.

3 No ground connection is required.

4 For end position indication, interlock control, fan startup, etc., NFBUP-S N4(H), NFXUP-S N4 incorporates two built-in auxiliary switches: 2 x SPDT, 3A (0.5A) @250 VAC, UL Approved, one switch is fixed at +10°, one is adjustable 10° to 90°.

APPLICATION NOTES

◆ Meets cULus requirements without the need of an electrical ground connection.

⚠ WARNING Live Electrical Components!
During installation, testing, servicing and troubleshooting of this product, it may be necessary to work with live electrical components. Have a qualified licensed electrician or other individual who has been properly trained in handling live electrical components perform these tasks. Failure to follow all electrical safety precautions when exposed to live electrical components could result in death or serious injury.

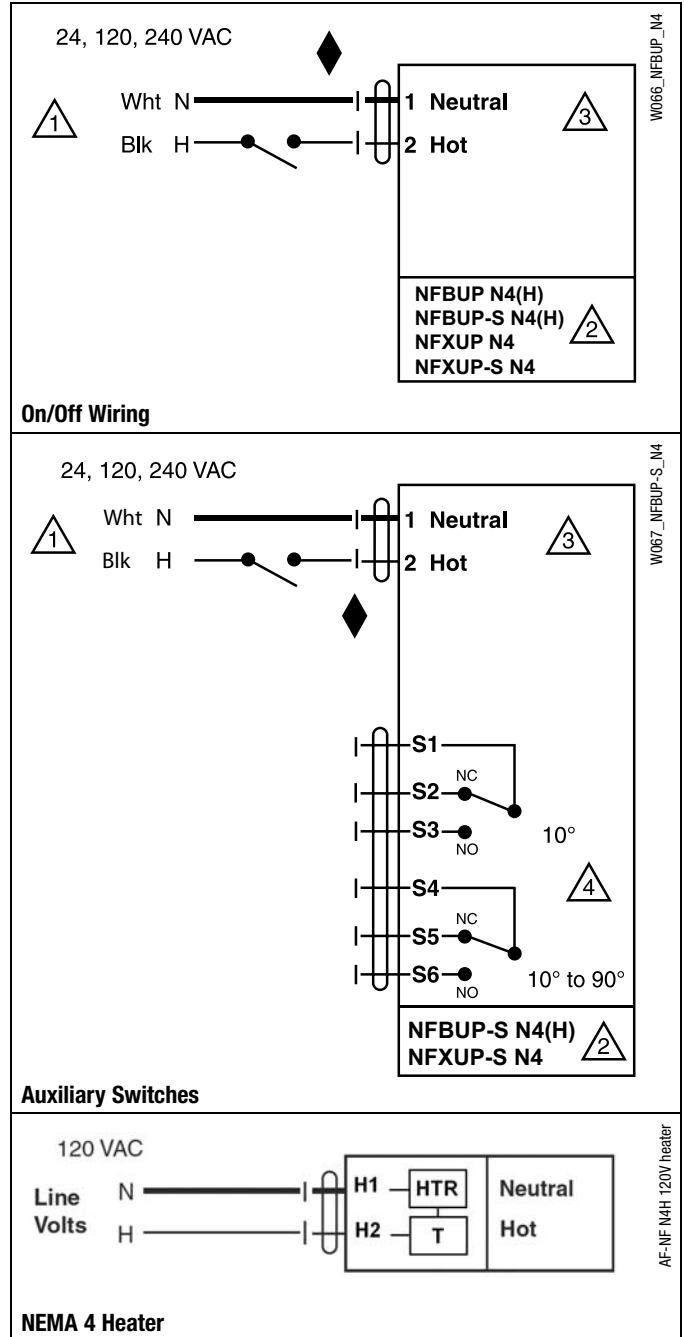

NFB24-SR, NFB24-SR-S, NFX24-SR, NFX24-SR-S

Proportional, Spring Return, 24 V, for 2 to 10 VDC or 4 to 20 mA Control Signal



Technical Data		NFB24-SR, NFB24-SR-S, NFX24-SR, NFX24-SR-S
Power supply		24 VAC ±20%, 50/60 Hz 24 VDC +20% / -10%
Power consumption	running	3.5 W
	holding	2.5 W
Transformer sizing		6 VA (class 2 power source)
Electrical connection	NFB...	3 ft, 18 GA appliance cable, 1/2" conduit connector -S models: two 3 ft, 18 gauge appliance cables with 1/2" conduit connectors
	NFX...	3 ft [1m], 10 ft [3m] or 16 ft [5m] 18 GA appliance or plenum cables, with or without 1/2" conduit connector -S models: Two 3 ft [1m], 10 ft [3m] or 16 ft [5m] appliance cables, with or without 1/2" conduit connectors
Overload protection		electronic throughout 0 to 95° rotation
Operating range Y		2 to 10 VDC, 4 to 20mA
Input impedance		100 kΩ for 2 to 10 VDC (0.1 mA)
		500 Ω for 4 to 20 mA
Feedback output U		2 to 10 VDC (max. 0.5 mA)
Torque		90 in-lb [10 Nm] minimum
Direction of rotation	spring	reversible with CW/CCW mounting
	motor	reversible with built-in switch
Mechanical angle of rotation		95° (adjustable with mechanical end stop, 35° to 95°)
Running time	spring	< 20 seconds @ -4°F to 122°F [-20°C to 50°C]; < 60 seconds @ -22°F [-30°C]
	motor	95 seconds
Position indication		visual indicator, 0° to 95° (0° is full spring return position)
Manual override		5 mm hex crank (3/16" Allen), supplied
Humidity		max. 95% RH non-condensing
Ambient temperature		-22°F to 122°F [-30°C to 50°C]
Storage temperature		-40°F to 176°F [-40°C to 80°C]
Housing		Nema 2, IP54, Enclosure Type2
Housing material		zinc coated metal and plastic casing
Agency listings†		cULus acc. to UL60730-1A/-2-14, CAN/CSA E60730-1:02, CE acc. to 2004/108/EC & 2006/95/EC
Noise level		≤40dB(A) motor @ 95 seconds ≤62dB(A) spring return
Servicing		maintenance free
Quality standard		ISO 9001
Weight		4.15 lbs (1.9 kg); 4.4 lbs (2.0 kg) with switches
† Rated Impulse Voltage 800V, Type of action 1.AA (1.AA.B for -S version), Control Pollution Degree 3.		
NFB24-SR-S, NFX24-SR-S		
Auxiliary switches		2 x SPDT 3A (0.5A) @ 250 VAC, UL approved one set at +10°, one adjustable 10° to 90°

Torque min. 90 in-lb, for control of air dampers

Application

For proportional modulation of dampers in HVAC systems. Actuator sizing should be done in accordance with the damper manufacturer's specifications.

The actuator is mounted directly to a damper shaft up to 1.05" in diameter by means of its universal clamp. A crank arm and several mounting brackets are available for applications where the actuator cannot be direct coupled to the damper shaft.

The actuator operates in response to a 2 to 10 VDC, or with the addition of a 500Ω resistor, a 4 to 20 mA control input from an electronic controller or positioner. A 2 to 10 VDC feedback signal is provided for position indication. Not to be used for a master-slave application.

Operation

The NFB and NFX series actuators provide true spring return operation for reliable fail-safe application and positive close-off on air tight dampers. The spring return system provides constant torque to the damper with, and without, power applied to the actuator.

The NFB and NFX series provides 95° of rotation and is provided with a graduated position indicator showing 0° to 95°.

The NFB24-SR and NFX24-SR uses a brushless DC motor which is controlled by an Application Specific Integrated Circuit (ASIC) and a microprocessor. The microprocessor provides the intelligence to the ASIC to provide a constant rotation rate and to know the actuator's exact fail-safe position. The ASIC monitors and controls the brushless DC motor's rotation and provides a digital rotation sensing function to prevent damage to the actuator in a stall condition. The actuator may be stalled anywhere in its normal rotation without the need of mechanical end switches.

The NFB24-SR-S and NFX24-SR-S versions are provided with two built-in auxiliary switches. These SPDT switches provide safety interfacing or signaling, for example, for fan start-up. The switching function at the fail-safe position is fixed at +10°, the other switch function is adjustable between +10° to +90°. The NFB24-SR, NFB24-SR-S, NFX24-SR and NFX24-SR-S actuator is shipped at +5° (5° from full fail-safe) to provide automatic compression against damper gaskets for tight shut-off.

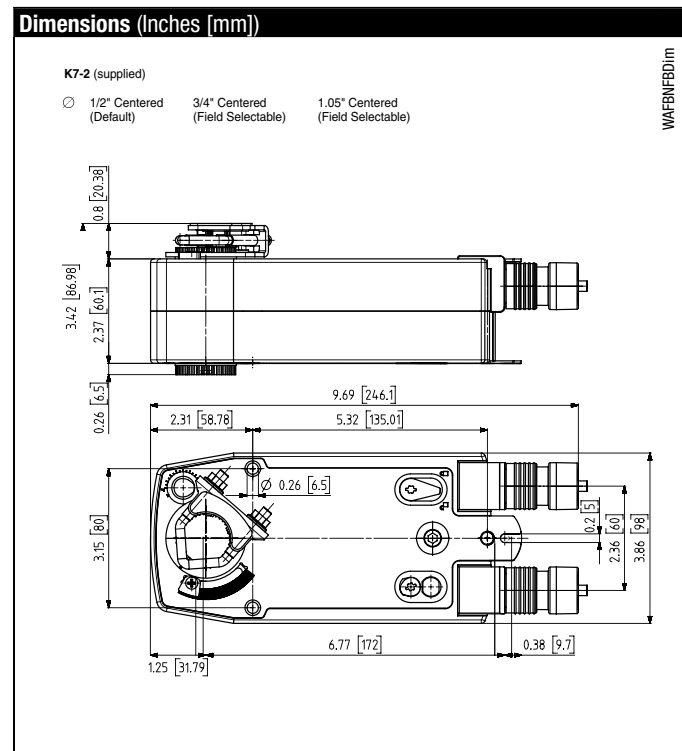

M40103 - 09/11 - Subject to change. © Belimo Aircontrols (USA), Inc.

Accessories

AV 8-25	Shaft extension
IND-AFB	Damper position indicator
KH-AFB	Crank arm
K7-2	Universal clamp for up to 1.05" dia jackshafts
TF-CC US	Conduit fitting
Tool-06	8mm and 10 mm wrench
ZG-100	Universal mounting bracket
ZG-101	Universal mounting bracket
ZG-118	Mounting bracket for Barber Colman® MA 3../4.., Honeywell® Mod III or IV or Johnson® Series 100 replacement or new crank arm type installations
ZG-AFB	Crank arm adaptor kit
ZG-AFB118	Crank arm adaptor kit
ZS-100	Weather shield (metal)
ZS-150	Weather shield (polycarbonate)
ZS-260	Explosion-proof housing
ZS-300	NEMA 4X housing

NOTE: When using NFB24-SR, NFB24-SR-S, NFX24-SR and NFX24-SR-S actuators, only use accessories listed on this page.
For actuator wiring information and diagrams, refer to Belimo Wiring Guide.

Typical Specification

Spring return control damper actuators shall be direct coupled type which require no crank arm and linkage and be capable of direct mounting to a jackshaft up to a 1.05" diameter. The actuator must provide proportional damper control in response to a 2 to 10 VDC or, with the addition of a 500Ω resistor, a 4 to 20 mA control input from an electronic controller or positioner. The actuators must be designed so that they may be used for either clockwise or counterclockwise fail-safe operation. Actuators shall use a brushless DC motor controlled by a microprocessor and be protected from overload at all angles of rotation. Run time shall be constant, and independent of torque. A 2 to 10 VDC feedback signal shall be provided for position feedback. Actuators shall be cULus Approved and have a 5 year warranty, and be manufactured under ISO 9001 International Quality Control Standards. Actuators shall be as manufactured by Belimo.

Wiring Diagrams

INSTALLATION NOTES

- 1 Provide overload protection and disconnect as required.
- 2 **CAUTION Equipment Damage!**
Actuators may be connected in parallel. Power consumption and input impedance must be observed.
- 3 Up to 4 actuators may be connected in parallel. With 4 actuators wired to one 500 Ω resistor. Power consumption must be observed.
- 4 Actuator may also be powered by 24 VDC.
- 5 For end position indication, interlock control, fan startup, etc., NFB24-SR-S and NFX24-SR-S incorporates two built-in auxiliary switches: 2 x SPDT, 3A (0.5A) @250 VAC, UL Approved, one switch is fixed at +10°, one is adjustable 10° to 90°.
- 6 Only connect common to neg. (-) leg of control circuits

APPLICATION NOTES

- ◆ The ZG-R01 500 Ω resistor converts the 4 to 20 mA control signal to 2 to 10 VDC.

WARNING Live Electrical Components!
During installation, testing, servicing and troubleshooting of this product, it may be necessary to work with live electrical components. Have a qualified licensed electrician or other individual who has been properly trained in handling live electrical components perform these tasks. Failure to follow all electrical safety precautions when exposed to live electrical components could result in death or serious injury.

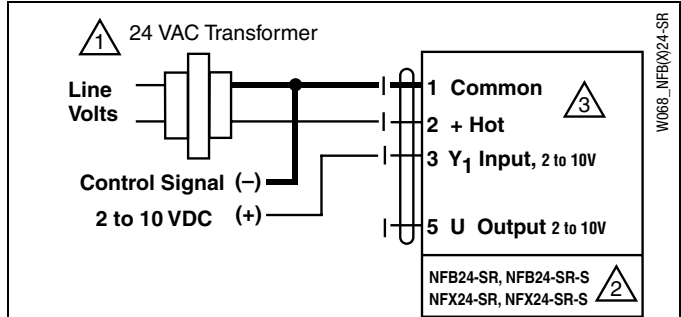

2 to 10 VDC control of NFB24-SR and NFX24-SR

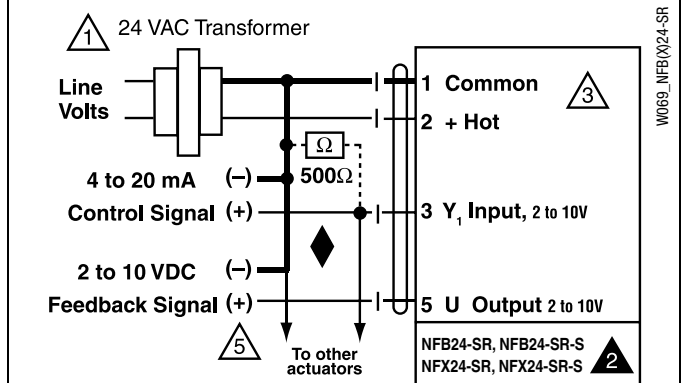

4 to 20 mA control of NFB24-SR and NFX24-SR with 2 to 10 VDC feedback output

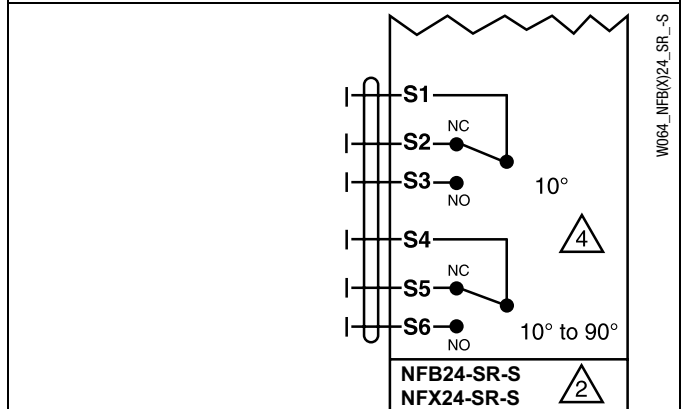

Auxiliary switches for NFB24-SR-S, NFX24-SR-S

NFB24-SR N4(H), NFB24-SR-S N4(H), NFX24-SR N4, NFX24-SR-S N4

NEMA 4, Proportional, Spring Return, 24 V, for 2 to 10 VDC or 4 to 20 mA Control Signal



Technical Data		NFB24-SR N4(H), NFB24-SR-S N4(H), NFX24-SR N4, NFX24-SR-S N4
Power supply		24 VAC ±20%, 50/60 Hz 24 VDC +20% / -10%
Power consumption	running holding	3.5 W / heater 25 W 2.5 W
Transformer sizing		6 VA (class 2 power source) / heater 25 VA
Electrical connection	NFB... N4	3 ft, 18 GA appliance cable, 1/2" conduit connector -S models: two 3 ft, 18 gauge appliance cables with 1/2" conduit connectors
	heater (N4H)	terminal block, 26-16 GA
	NFX... N4	3 ft [1m], 10 ft [3m] or 16 ft [5m] 18 GA appliance or plenum cables, with 1/2" conduit connector -S models: two 3 ft [1m], 10 ft [3m] or 16 ft [5m] appliance cables with 1/2" conduit connectors
Overload protection		electronic throughout 0 to 95° rotation
Operating range Y		2 to 10 VDC, 4 to 20mA
Input impedance		100 kΩ for 2 to 10 VDC (0.1 mA) 500 Ω for 4 to 20 mA
Feedback output U		2 to 10 VDC (max. 0.5 mA)
Torque		90 in-lb [10 Nm] minimum
Direction of rotation	spring motor	reversible with CW/CCW mounting inside housing reversible with built-in switch
Mechanical angle of rotation		95° (adjustable with mechanical end stop, 35° to 95°)
Running time	motor spring	95 seconds < 20 seconds @ -4°F to 122°F [-20°C to 50°C]; < 60 seconds @ -22°F [-30°C]
	spring (with heater)	< 20 seconds @ -4°F to 122°F [-20°C to 50°C]; < 60 seconds @ -49°F [-45°C]
Position indication		visual indicator, 0° to 95° (0° is full spring return position)
Manual override		5 mm hex crank (3/16" Allen), supplied
Humidity		max. 95% RH non-condensing
Ambient temperature		-22°F to 122°F [-30°C to 50°C]
	with heater	-49°F to 122°F [-45°C to 50°C]
Storage temperature		-40°F to 176°F [-40°C to 80°C]
Housing		UL Type 4, NEMA 4, IP66
Housing material		polycarbonate
Agency listings†		cULus acc. to UL60730-1A/-2-14, CAN/CSA E60730-1:02, CE acc. to 2004/108/EC & 2006/95/EC
Noise level		≤40dB(A) motor @ 95 seconds ≤62dB(A) spring return
Servicing		maintenance free
Quality standard		ISO 9001
Weight		9.25 lbs (4.2 kg); 9.5 lbs (4.3 kg) with switches 10 lbs (4.5 kg) with heater

† Rated Impulse Voltage 800V, Type of action 1.AA (1.AA.B for -S version), Control Pollution Degree 4.

NFB24-SR-S N4(H), NFB24-SR-S N4	
Auxiliary switches	2 x SPDT 3A (0.5A) @ 250 VAC, UL approved one set at +10°, one adjustable 10° to 90°

Torque min. 90 in-lb, for control of air dampers

Application

For proportional modulation of dampers in HVAC systems. Actuator sizing should be done in accordance with the damper manufacturer's specifications.

The actuator is mounted directly to a damper shaft up to 1.05" in diameter by means of its universal clamp. A crank arm and several mounting brackets are available for applications where the actuator cannot be direct coupled to the damper shaft.

The actuator operates in response to a 2 to 10 VDC, or with the addition of a 500Ω resistor, a 4 to 20 mA control input from an electronic controller or positioner. A 2 to 10 VDC feedback signal is provided for position indication. Not to be used for a master-slave application.

Operation

The NFB N4(H), NFX N4 series actuators provide true spring return operation for reliable fail-safe application and positive close-off on air tight dampers. The spring return system provides constant torque to the damper with, and without, power applied to the actuator.

The NFB N4(H), NFX N4 series provides 95° of rotation and is provided with a graduated position indicator showing 0° to 95°.

The NFB24-SR N4(H), NFX24-SR N4 uses a brushless DC motor which is controlled by an Application Specific Integrated Circuit (ASIC) and a microprocessor. The microprocessor provides the intelligence to the ASIC to provide a constant rotation rate and to know the actuator's exact fail-safe position. The ASIC monitors and controls the brushless DC motor's rotation and provides a digital rotation sensing function to prevent damage to the actuator in a stall condition. The actuator may be stalled anywhere in its normal rotation without the need of mechanical end switches.

The NFB24-SR-S N4(H), NFX24-SR-S N4 version are provided with two built-in auxiliary switches. These SPDT switches provide safety interfacing or signaling, for example, for fan start-up. The switching function at the fail-safe position is fixed at +10°, the other switch function is adjustable between +10° to +90°.

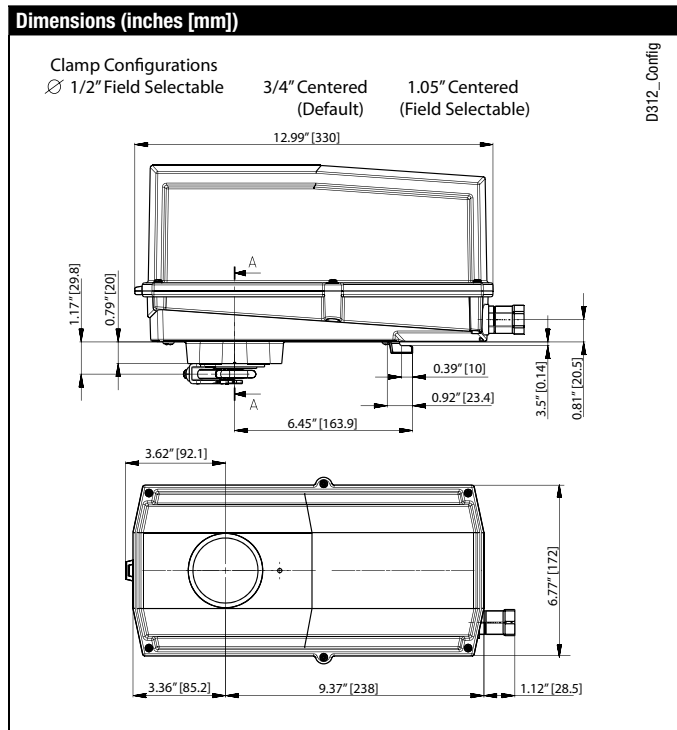

M40103 - 09/11 - Subject to change. © Belimo Aircontrols (USA), Inc.

Accessories

Tool-06	8mm and 10 mm wrench
43442-00001	Gland (needed for additional wires)
11097-00001	Gasket for Gland (needed for additional wires)

NOTE: When using NFB24-SR N4(H), NFB24-SR-S N4(H), NFX24-SR N4, NFX24-SR-S N4 actuators, only use accessories listed on this page.
For actuator wiring information and diagrams, refer to Belimo Wiring Guide.

Typical Specification

Spring return control damper actuators shall be direct coupled type which require no crank arm and linkage and be capable of direct mounting to a jackshaft up to a 1.05" diameter. The actuator must provide proportional damper control in response to a 2 to 10 VDC or, with the addition of a 500 Ω resistor, a 4 to 20 mA control input from an electronic controller or positioner. The actuators must be designed so that they may be used for either clockwise or counterclockwise fail-safe operation. Actuators shall use a brushless DC motor controlled by a microprocessor and be protected from overload at all angles of rotation. Run time shall be constant, and independent of torque. A 2 to 10 VDC feedback signal shall be provided for position feedback. Actuators shall be cULus Approved and have a 5 year warranty, and be manufactured under ISO 9001 International Quality Control Standards. Actuators shall be as manufactured by Belimo.

Wiring Diagrams

INSTALLATION NOTES

- 1 Provide overload protection and disconnect as required.
- 2 **CAUTION Equipment Damage!**
Actuators may be connected in parallel. Power consumption and input impedance must be observed.
- 3 Up to 4 actuators may be connected in parallel. With 4 actuators wired to one 500 Ω resistor. Power consumption must be observed.
- 4 Actuator may also be powered by 24 VDC.
- 5 For end position indication, interlock control, fan startup, etc., NFB24-SR-S N4(H), NFX24-SR-S N4 incorporates two built-in auxiliary switches: 2 x SPDT, 3A (0.5A) @250 VAC, UL Approved, one switch is fixed at +10°, one is adjustable 10° to 90°.
- 6 Only connect common to neg. (-) leg of control circuits

APPLICATION NOTES

- ◆ The ZG-R01 500 Ω resistor converts the 4 to 20 mA control signal to 2 to 10 VDC.

WARNING Live Electrical Components!
During installation, testing, servicing and troubleshooting of this product, it may be necessary to work with live electrical components. Have a qualified licensed electrician or other individual who has been properly trained in handling live electrical components perform these tasks. Failure to follow all electrical safety precautions when exposed to live electrical components could result in death or serious injury.

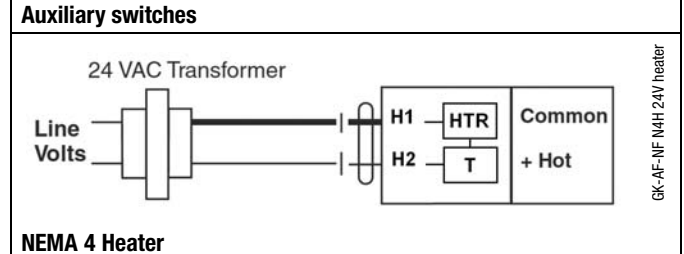
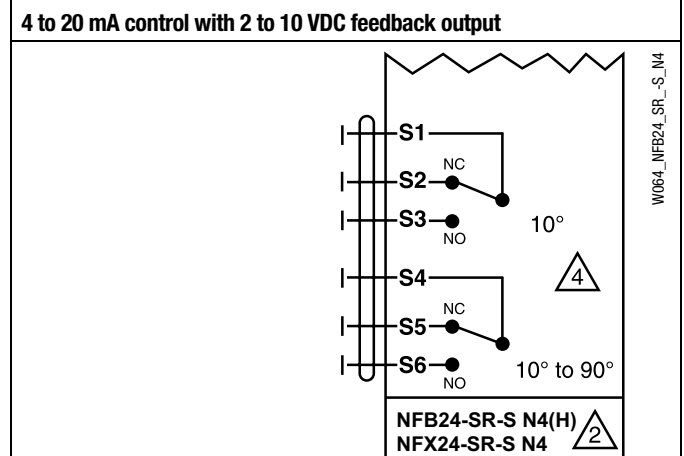
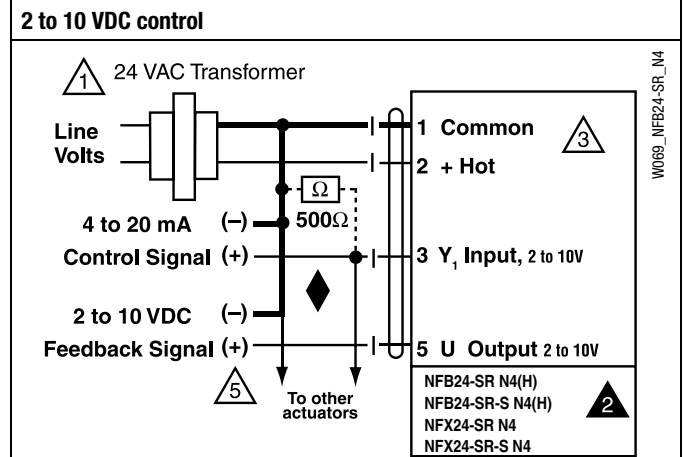
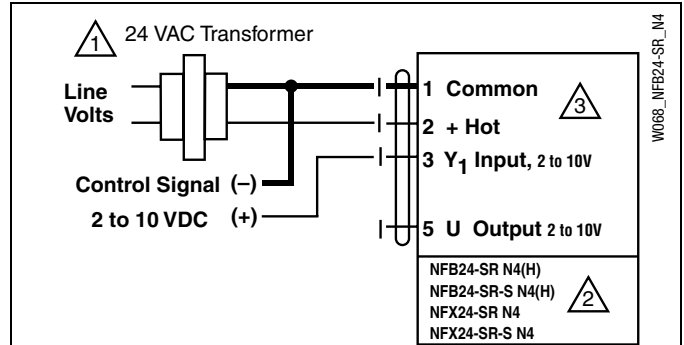

NFB24-MFT, NFB24-MFT-S, NFX24-MFT, NFX24-MFT-S

Proportional, Spring Return, Multi-Function Technology®



MFT



Technical Data		NFB24-MFT, NFB24-MFT-S, NFX24-MFT, NFX24-MFT-S
Power supply		24 VAC ±20%, 50/60 Hz 24 VDC +20% / -10%
Power consumption	running	6.5 W
	holding	3 W
Transformer sizing		9 VA (class 2 power source)
Electrical connection		
	NFB...	3 ft, 18 GA appliance cable, 1/2" conduit connector -S models: two 3 ft, 18 gauge appliance cables with 1/2" conduit connectors
	NFX...	3 ft [1m], 10 ft [3m] or 16 ft [5m] 18 GA appliance or plenum cables, with or without 1/2" conduit connector -S models: Two 3 ft [1m], 10 ft [3m] or 16 ft [5m] appliance cables with or without 1/2" conduit connectors
Overload protection		electronic throughout 0 to 95° rotation
Operating range Y*		2 to 10 VDC, 4 to 20mA (default) variable (VDC, PWM, floating point, on/off)
Input impedance		100 kΩ for 2 to 10 VDC (0.1 mA) 500 Ω for 4 to 20 mA 1500 Ω for PWM, floating point, on/off
Feedback output U*		2 to 10 VDC (max. 0.5 mA)
Torque		90 in-lb [10 Nm] minimum
Direction of rotation*	spring motor	reversible with CW/CCW mounting reversible with built-in switch
Mechanical angle of rotation*		95° (adjustable with mechanical end stop, 35° to 95°)
Running time	spring	< 20 sec @ -4°F to 122°F [-20°C to 50°C]; < 60 sec @ -22°F [-30°C]
	motor*	150 seconds (default), variable (40 to 220 secs)
Angle of Rotation Adaptation*		off (Default)
Override control*		min position = 0% mid. position = 50% max. position = 100%
Position indication		visual indicator, 0° to 95° (0° is full spring return position)
Manual override		5 mm hex crank (3/16" Allen), supplied
Humidity		max. 95% RH non-condensing
Ambient temperature		-22°F to 122°F [-30°C to 50°C]
Storage temperature		-40°F to 176°F [-40°C to 80°C]
Housing		Nema 2, IP54, Enclosure Type2
Housing material		zinc coated metal and plastic casing
Agency listings†		cULus acc. to UL60730-1A/-2-14, CAN/CSA E60730-1:02, CE acc. to 2004/108/EC & 2006/95/EC
Noise level		≤40dB(A) motor @ 150 seconds, run time dependent ≤62dB(A) spring return
Servicing		maintenance free
Quality standard		ISO 9001
Weight		4.2 lbs (1.9 kg), 4.4 lbs (2.0 kg) with switches
*Variable when configured with MFT options.		
† Rated Impulse Voltage 800V, Type of action 1.AA.B for -S version), Control Pollution Degree 3.		
♦ Programmed for 40 sec motor run time. At 150 sec motor run time, transformer sizing is 6.5 VA and power consumption is 4.5 W running / 3 W holding.		
NFB24-MFT-S, NFX24-MFT-S		
Auxiliary switches		2 x SPDT 3A (0.5A) @ 250 VAC, UL approved one set at +10°, one adjustable 10° to 90°

- Torque min. 90 in-lb
- Control 2 to 10 VDC (DEFAULT)
- Feedback 2 to 10 VDC (DEFAULT)

Application

For proportional modulation of dampers and control valves in HVAC systems. The NFB24-MFT and NFX24-MFT provides mechanical spring return operation for reliable fail-safe application.

Default/Configuration

Default parameters for 2 to 10 VDC applications of the NFB24-MFT and NFX24-MFT actuator are assigned during manufacturing. If required, custom versions of the actuator can be ordered. The parameters noted in the Technical Data table are variable.

These parameters can be changed by three means:

- Pre-set configurations from Belimo
- Custom configurations from Belimo
- Configurations set by the customer using the MFT PC tool (version 3.4 or higher) software application.
- Handheld ZTH-GEN

Operation

The NFB24-MFT, NFX24-MFT actuator provides 95° of rotation and is provided with a graduated position indicator showing 0° to 95°. The actuator will synchronize the 0° mechanical stop or the damper or valves mechanical stop and use this point for its zero position during normal control operations.

The actuator uses a brushless DC motor which is controlled by an Application Specific Integrated Circuit (ASIC) and a microprocessor. The microprocessor provides the intelligence to the ASIC to provide a constant rotation rate and to know the actuator's exact position. The ASIC monitors and controls the brushless DC motor's rotation and provides a Digital Rotation Sensing (DRS) function to prevent damage to the actuator in a stall condition. The position feedback signal is generated with out the need for mechanical feedback potentiometers using DRS. The actuator may be stalled anywhere in its normal rotation without the need of mechanical end switches.

The NFB24-MFT, NFB24-MFT-S, NFX24-MFT and NFX24-MFT-S is mounted directly to control shafts up to 1.05" diameter by means of its universal clamp and anti-rotation bracket. A crank arm and several mounting brackets are available for damper applications where the actuator cannot be direct coupled to the damper shaft. The spring return system provides minimum specified torque to the application during a power interruption. The NFB24-MFT, NFB24-MFT-S, NFX24-MFT and NFX24-MFT-S actuator is shipped at +5° (5° from full fail-safe) to provide automatic compression against damper gaskets for tight shut-off.

NOTE: Refer to Multi-Function Technology documentation.

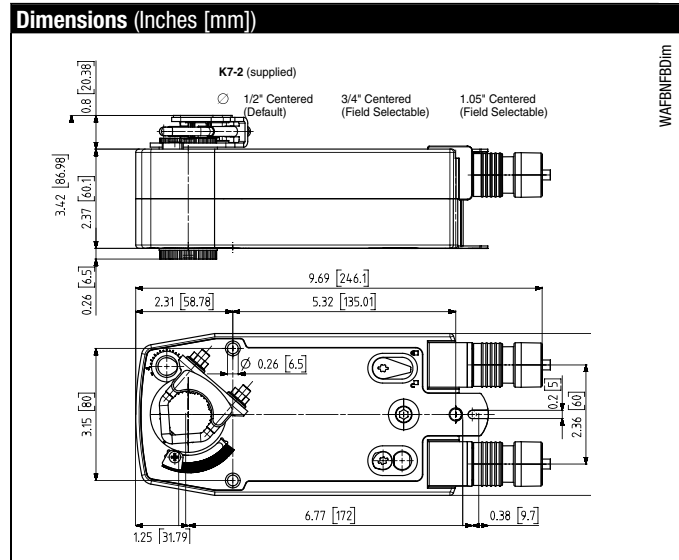

M40103 - 09/11 - Subject to change. © Belimo Aircontrols (USA), Inc.

Accessories

AV 8-25	Shaft extension
IND-AFB	Damper position indicator
KH-AFB	Crank arm
K7-2	Universal clamp for up to 1.05" dia jackshafts
TF-CC US	Conduit fitting
Tool-06	8mm and 10 mm wrench
ZG-100	Universal mounting bracket
ZG-101	Universal mounting bracket
ZG-118	Mounting bracket for Barber Colman® MA 3./4., Honeywell® Mod III or IV or Johnson® Series 100 replacement or new crank arm type installations
ZG-AFB	Crank arm adaptor kit
ZG-AFB118	Crank arm adaptor kit
ZS-100	Weather shield (metal)
ZS-150	Weather shield (polycarbonate)
ZS-260	Explosion-proof housing
ZS-300	NEMA 4X housing

NOTE: When using NFB24-MFT, NFB24-MFT-S, NFX24-MFT and NFX24-MFT-S actuators, only use accessories listed on this page. For actuator wiring information and diagrams, refer to Belimo Wiring Guide.

Typical Specification

Spring return control damper actuators shall be direct coupled type which require no crank arm and linkage and be capable of direct mounting to a jackshaft up to a 1.05" diameter. The actuator must provide proportional damper control in response to a 2 to 10 VDC or, with the addition of a 500Ω resistor, a 4 to 20 mA control input from an electronic controller or positioner. The actuators must be designed so that they may be used for either clockwise or counterclockwise fail-safe operation. Actuators shall use a brushless DC motor controlled by a microprocessor and be protected from overload at all angles of rotation. Run time shall be constant, and independent of torque. A 2 to 10 VDC feedback signal shall be provided for position feedback. Actuators shall be cULus Approved and have a 5 year warranty, and be manufactured under ISO 9001 International Quality Control Standards. Actuators shall be as manufactured by Belimo.

Wiring Diagrams

INSTALLATION NOTES

- 1 Provide overload protection and disconnect as required.
- 2 **CAUTION Equipment Damage!** Actuators may be connected in parallel if not mechanically mounted to the same shaft. Power consumption and input impedance must be observed.
- 3 Actuators may also be powered by 24 VDC.
- 4 Position feedback cannot be used with Triac sink controller. The actuator internal common reference is not compatible.
- 5 Control signal may be pulsed from either the Hot (source) or the Common (sink) 24 VAC line.
- 8 Contact closures A & B also can be triacs.
- 9 For triac sink the common connection from the actuator must be connected to the hot connection of the controller.

APPLICATION NOTES

◆ Meets UL requirements without the need of an electrical ground connection.

◆ The ZG-R01 500 Ω resistor may be used.

WARNING Live Electrical Components!

During installation, testing, servicing and troubleshooting of this product, it may be necessary to work with live electrical components. Have a qualified licensed electrician or other individual who has been properly trained in handling live electrical components perform these tasks. Failure to follow all electrical safety precautions when exposed to live electrical components could result in death or serious injury.

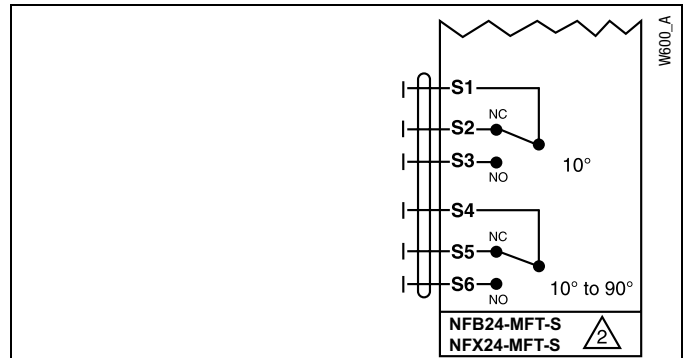

Auxiliary Switches for NFB24-MFT-S, NFX24-MFT-S

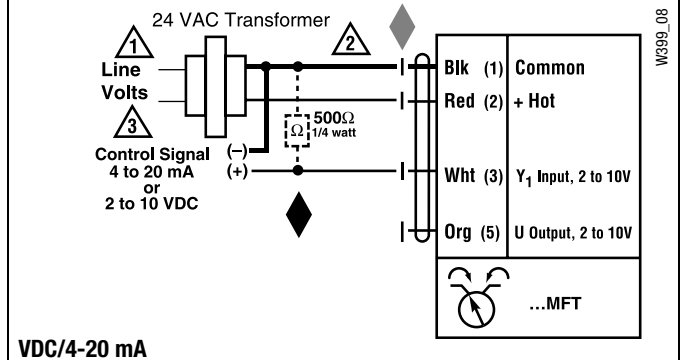

VDC/4-20 mA

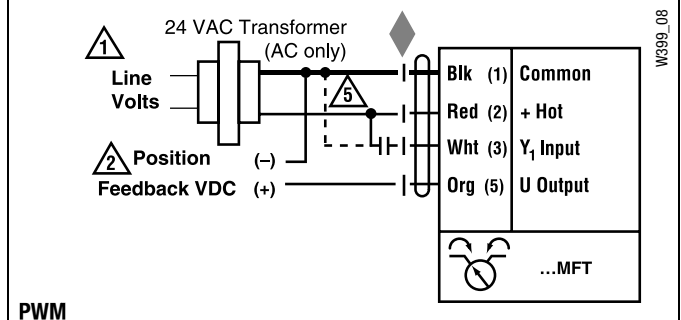

PWM

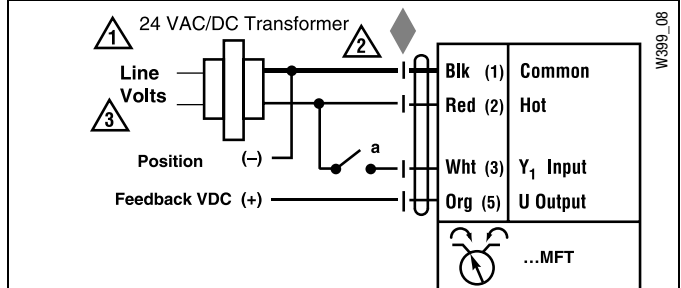

On/Off control

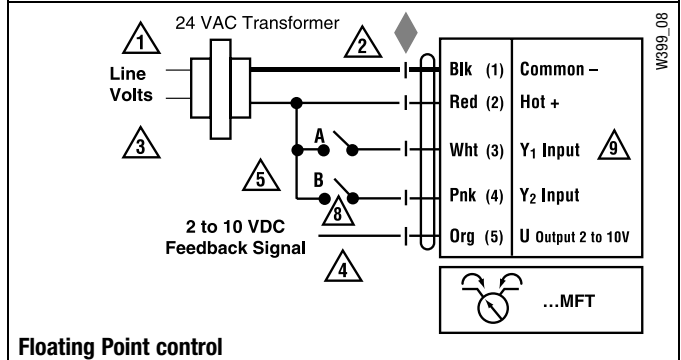

Floating Point control

NFB24-MFT N4(H), NFB24-MFT-S N4(H), NFX24-MFT N4, NFX24-MFT-S N4



NEMA 4, Proportional, Spring Return, Multi-Function Technology®



MFT



Technical Data		NFB24-MFT N4(H), NFB24-MFT-S N4(H), NFX24-MFT N4, NFX24-MFT-S N4
Power supply		24 VAC ±20%, 50/60 Hz 24 VDC +20% / -10%
Power consumption	running holding	6.5 W / heater 25 W 3 W
Transformer sizing		9 VA (class 2 power source) / heater 25 VA
Electrical connection	NFB... N4	3 ft, 18 GA appliance cable, 1/2" conduit connector -S models: two 3 ft, 18 gauge appliance cables with 1/2" conduit connectors
	heater (N4H)	terminal block, 26-16 GA
	NFX... N4	3 ft [1m], 10 ft [3m] or 16 ft [5m] 18 GA appliance or plenum cables, with 1/2" conduit connector -S models: two 3 ft [1m], 10 ft [3m] or 16 ft [5m] appliance cables with 1/2" conduit connectors
Overload protection		electronic throughout 0 to 95° rotation
Operating range Y*		2 to 10 VDC, 4 to 20mA (default) variable (VDC, PWM, floating point, on/off)
Input impedance		100 kΩ for 2 to 10 VDC (0.1 mA) 500 Ω for 4 to 20 mA 1500 Ω for PWM, floating point, on/off
Feedback output U*		2 to 10 VDC (max. 0.5 mA)
Torque		90 in-lb [10 Nm] minimum
Direction of rotation*	spring motor	reversible with CW/CCW mounting inside housing reversible with built-in switch
Mechanical angle of rotation*		95° (adjustable with mechanical end stop, 35° to 95°)
Running time	motor* spring	150 seconds (default), variable (40 to 220 secs) < 20 sec @ -4°F to 122°F [-20°C to 50°C]; < 60 sec @ -22°F [-30°C]
	spring (with heater)	< 20 sec @ -4°F to 122°F [-20°C to 50°C]; < 60 sec @ -49°F [-45°C]
Angle of rotation adaptation*		off (Default)
Override control*		min position = 0% mid. position = 50% max. position = 100%
Position indication		visual indicator, 0° to 95° (0° is full spring return position)
Manual override		5 mm hex crank (3/16" allen), supplied
Humidity		max. 95% RH non-condensing
Ambient temperature		-22°F to 122°F [-30°C to 50°C]
	with heater	-49°F to 122°F [-45°C to 50°C]
Storage temperature		-40°F to 176°F [-40°C to 80°C]
Housing		UL Type 4, NEMA 4, IP66
Housing material		polycarbonate
Agency listings†		cULus acc. to UL60730-1A/-2-14, CAN/CSA E60730-1:02, CE acc. to 2004/108/EC & 2006/95/EC
Noise level		≤40dB(A) motor @ 150 seconds, run time dependent ≤62dB(A) spring return
Servicing		maintenance free
Quality standard		ISO 9001
Weight		9.3 lbs (4.2 kg), 9.5 lbs (4.3 kg) with switches 10 lbs (4.5 kg) with heater

*Variable when configured with MFT options.

† Rated Impulse Voltage 800V, Type of action 1.AA (1.AA.B for -S version), Control Pollution Degree 4.

♦ Programmed for 40 sec motor run time. At 150 sec motor run time, transformer sizing is 6.5 VA and power consumption is 4.5 W running / 3 W holding.

NFB24-MFT-S N4(H), NFX24-MFT-S N4

Auxiliary switches 2 x SPDT 3A (0.5A) @ 250 VAC, UL approved one set at +10°, one adjustable 10° to 90°

- Torque min. 90 in-lb
- Control 2 to 10 VDC (DEFAULT)
- Feedback 2 to 10 VDC (DEFAULT)

Application

For proportional modulation of dampers and control valves in HVAC systems. The NFB24-MFT N4(H) and NFX24-MFT N4 provides mechanical spring return operation for reliable fail-safe application.

Default/Configuration

Default parameters for 2 to 10 VDC applications of the NFB24-MFT N4(H) and NFX24-MFT N4 actuator are assigned during manufacturing. If required, custom versions of the actuator can be ordered. The parameters noted in the Technical Data table are variable.

These parameters can be changed by three means:

- Pre-set configurations from Belimo
- Custom configurations from Belimo
- Configurations set by the customer using the MFT PC tool (version 3.4 or higher) software application.
- Handheld ZTH-GEN

Operation

The NFB24-MFT N4(H), NFX24-MFT N4 actuator provides 95° of rotation and is provided with a graduated position indicator showing 0° to 95°. The actuator will synchronize the 0° mechanical stop or the damper or valves mechanical stop and use this point for its zero position during normal control operations.

The actuator uses a brushless DC motor which is controlled by an Application Specific Integrated Circuit (ASIC) and a microprocessor. The microprocessor provides the intelligence to the ASIC to provide a constant rotation rate and to know the actuator's exact position. The ASIC monitors and controls the brushless DC motor's rotation and provides a Digital Rotation Sensing (DRS) function to prevent damage to the actuator in a stall condition. The position feedback signal is generated with out the need for mechanical feedback potentiometers using DRS. The actuator may be stalled anywhere in its normal rotation without the need of mechanical end switches.

The NFB24-MFT N4(H), NFB24-MFT-S N4(H), NFX24-MFT N4 and NFX24-MFT-S N4 is mounted directly to control shafts up to 1.05" diameter by means of its universal clamp and anti-rotation bracket. A crank arm and several mounting brackets are available for damper applications where the actuator cannot be direct coupled to the damper shaft. The spring return system provides minimum specified torque to the application during a power interruption.

NOTE: Refer to Multi-Function Technology documentation.

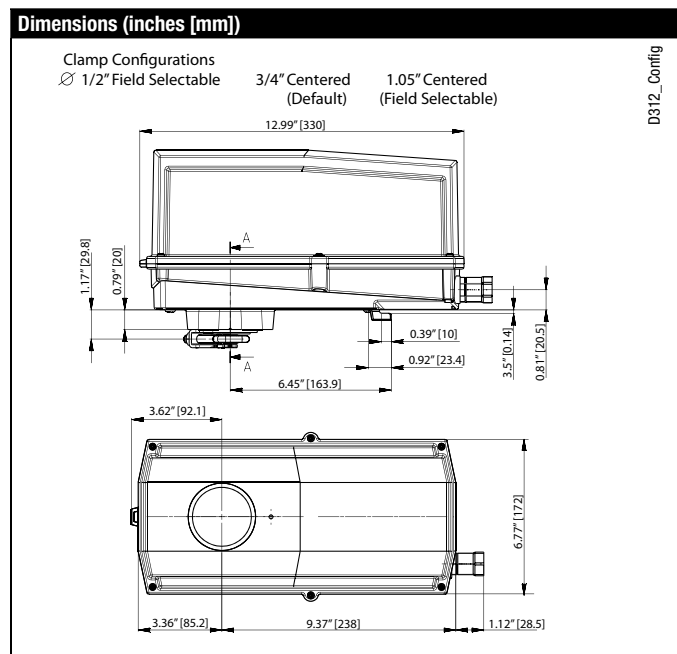

M40103 - 09/11 - Subject to change. © Belimo Aircontrols (USA), Inc.

Accessories

Tool-06	8mm and 10 mm wrench
43442-00001	Gland (needed for additional wires)
11097-00001	Gasket for Gland (needed for additional wires)

NOTE: When using NFB24-MFT N4(H), NFB24-MFT-S N4(H), NFX24-MFT N4, NFX24-MFT-S N4 actuators, only use accessories listed on this page.
For actuator wiring information and diagrams, refer to Belimo Wiring Guide.

Typical Specification

Spring return control damper actuators shall be direct coupled type which require no crank arm and linkage and be capable of direct mounting to a jackshaft up to a 1.05" diameter. The actuator must provide proportional damper control in response to a 2 to 10 VDC or, with the addition of a 500 Ω resistor, a 4 to 20 mA control input from an electronic controller or positioner. The actuators must be designed so that they may be used for either clockwise or counterclockwise fail-safe operation. Actuators shall use a brushless DC motor controlled by a microprocessor and be protected from overload at all angles of rotation. Run time shall be constant, and independent of torque. A 2 to 10 VDC feedback signal shall be provided for position feedback. Actuators shall be cULus Approved and have a 5 year warranty, and be manufactured under ISO 9001 International Quality Control Standards. Actuators shall be as manufactured by Belimo.

Wiring Diagrams

INSTALLATION NOTES

- 1 Provide overload protection and disconnect as required.
- 2 **CAUTION Equipment Damage!** Actuators may be connected in parallel if not mechanically mounted to the same shaft. Power consumption and input impedance must be observed.
- 3 Actuators may also be powered by 24 VDC.
- 4 Position feedback cannot be used with Triac sink controller. The actuator internal common reference is not compatible. Control signal may be pulsed from either the Hot (source) or the Common (sink) 24 VAC line.
- 5 Contact closures A & B also can be triacs.
- 8 A & B should both be closed for triac source and open for triac sink.
- 9 For triac sink the common connection from the actuator must be connected to the hot connection of the controller.

APPLICATION NOTES

- ◆ Meets UL requirements without the need of an electrical ground connection.
- ◆ The ZG-R01 500 Ω resistor may be used.

WARNING Live Electrical Components!

During installation, testing, servicing and troubleshooting of this product, it may be necessary to work with live electrical components. Have a qualified licensed electrician or other individual who has been properly trained in handling live electrical components perform these tasks. Failure to follow all electrical safety precautions when exposed to live electrical components could result in death or serious injury.

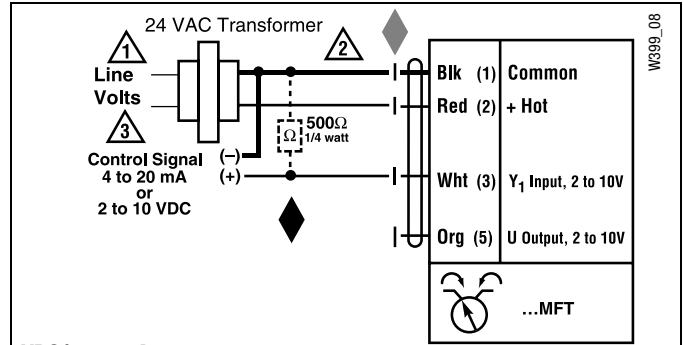

VDC/4-20 mA

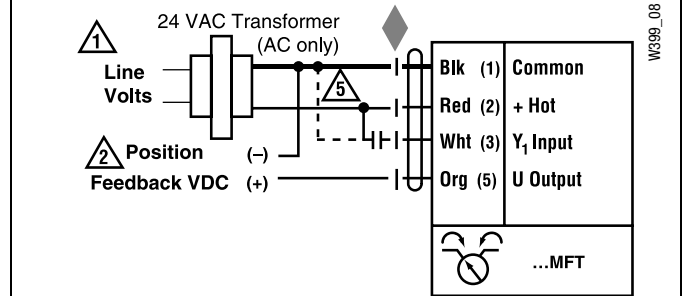

PWM

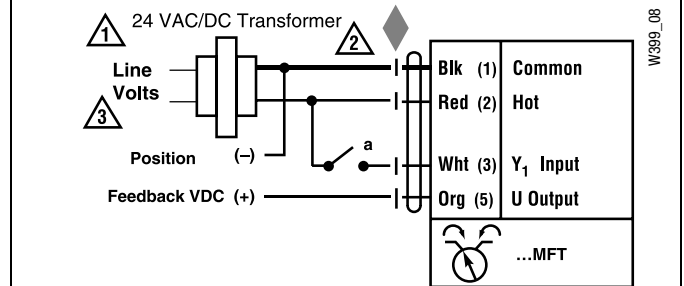

On/Off Control

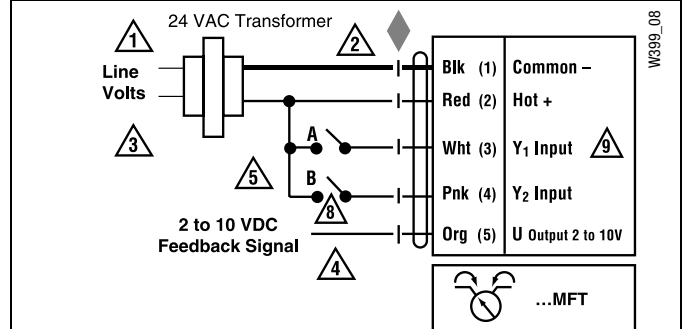

Floating Point Control

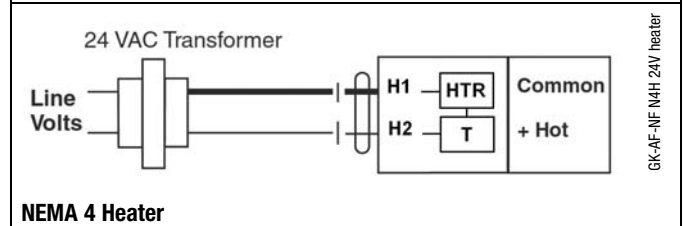

NEMA 4 Heater

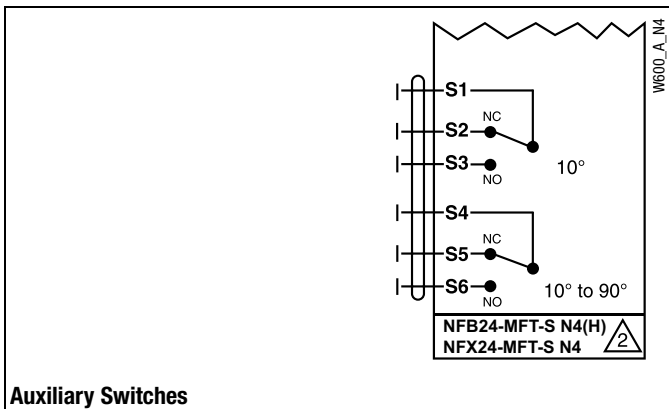

Auxiliary Switches

Installation Instructions

Quick-Mount Visual Instructions for Mechanical Installation



Quick-Mount Visual Instructions

1. Rotate the damper to its failsafe position.
If the shaft rotates counterclockwise, mount the "CCW" side of the actuator out.
If it rotates clockwise, mount the actuator with the "CW" side out.
2. If the universal clamp is not on the correct side of the actuator, move it to the correct side for ease of installation.
3. Slide the actuator onto the shaft and tighten the nuts on the V-bolt with a 10mm wrench to 6-8 ft-lb of torque.
4. Slide the anti-rotation strap under the actuator so that it engages the slot at the base of the actuator. Secure the strap to the duct work with #8 self-tapping screws.

NOTE: Read the "Standard Mounting" instructions, on the next page, for more detailed information.

Dimensions (Inches [mm])

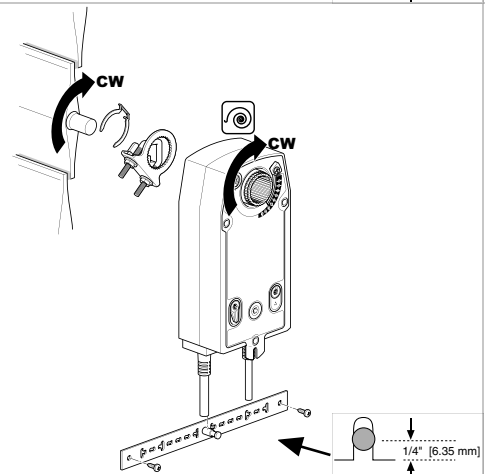
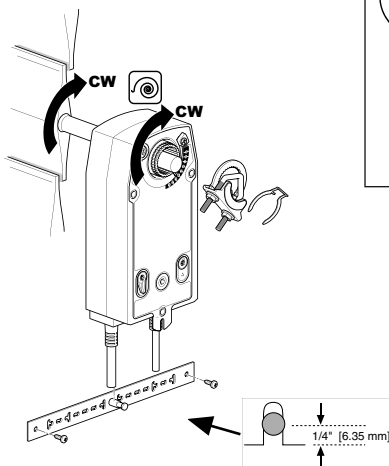
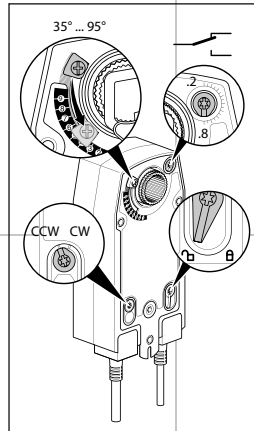
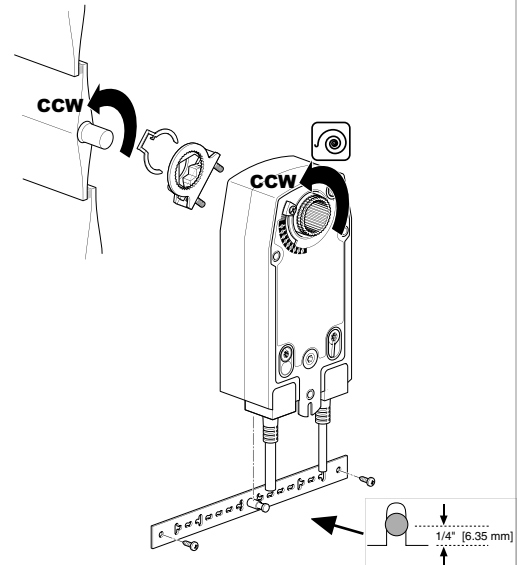
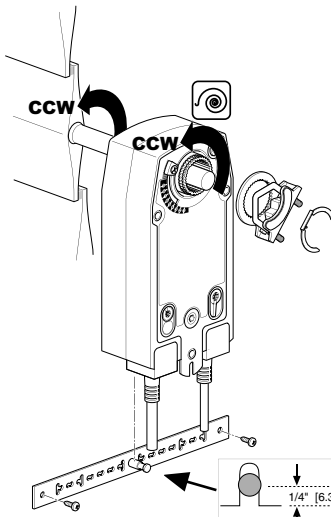
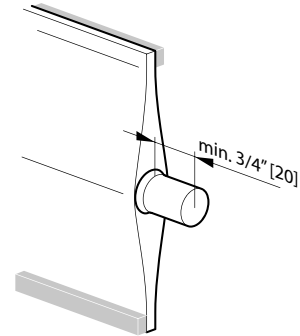
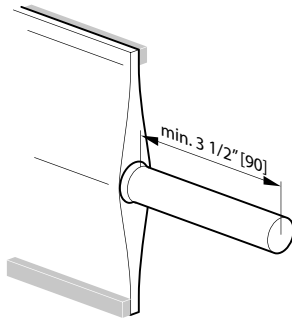

M40103 - 09/11 - Subject to change. © Belimo Aircontrols (USA), Inc.

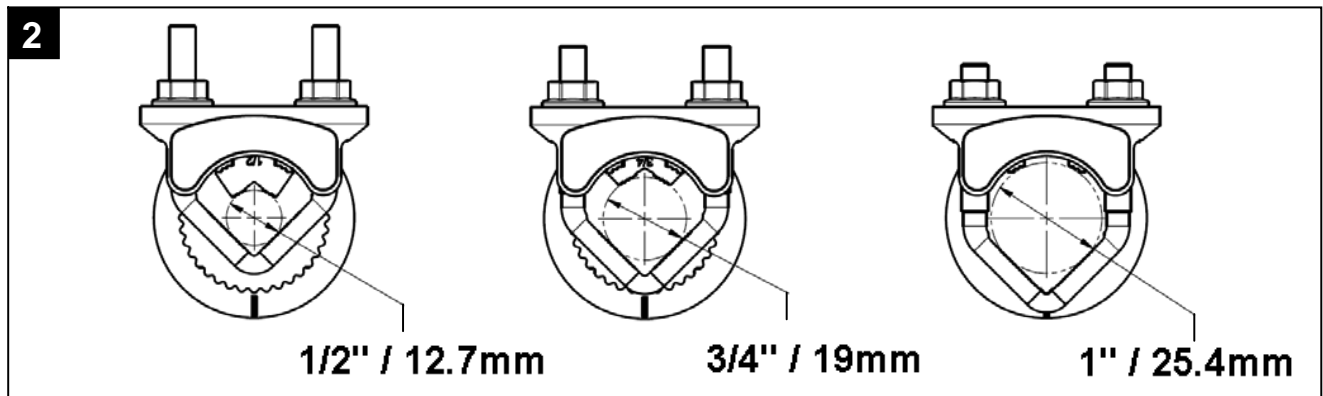
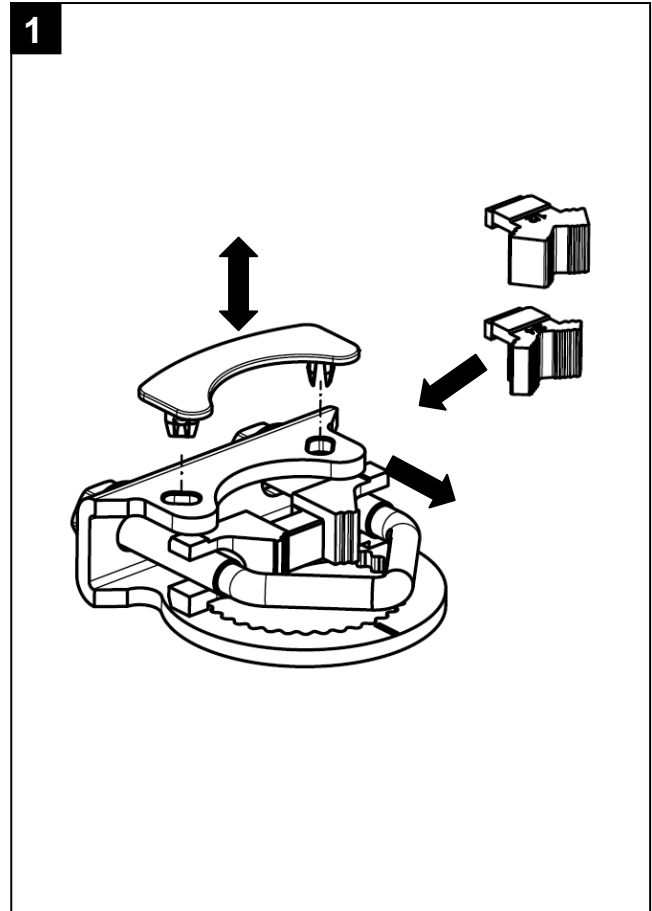
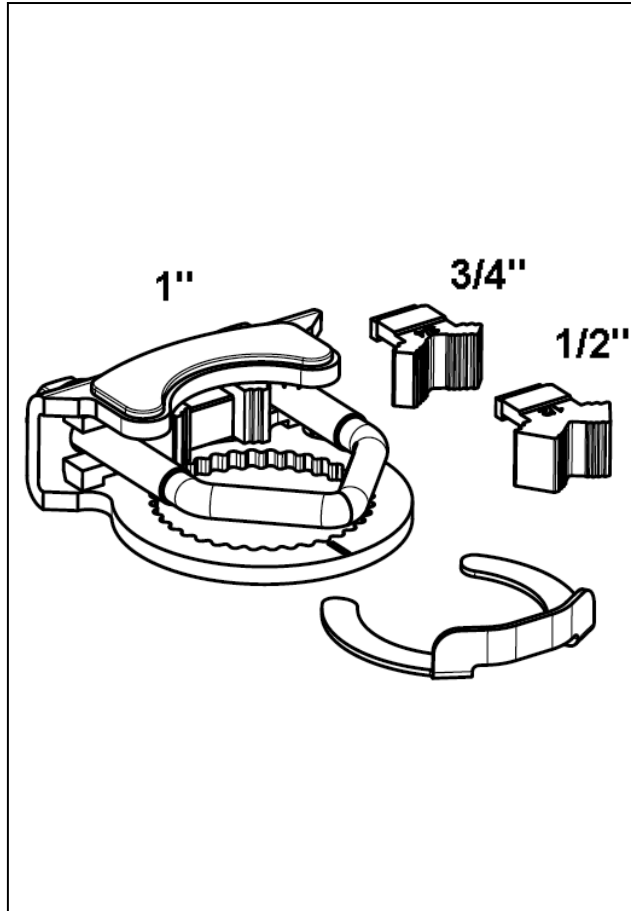

1/2"	3/4"	1"
1/2"	3/4"	1"
mm	mm	mm
12.7	19	25.4
inch	inch	inch
1/2	3/4	1
mm	mm	mm
10 ... 19	10 ... 22	19 ... 26.7
inch	inch	inch
2/5 ... 3/4	2/5 ... 3/4	3/4 ... 1.05
mm	mm	mm
---	10	12 ... 18
inch	inch	inch
---	3/8	1/2 ... 11/16
mm	mm	mm
14 ... 20	14 ... 25.4	---
inch	inch	---
9/16 ... 3/4	9/16 ... 1	---

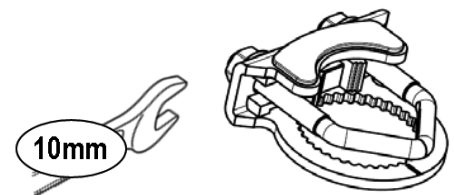

9 Nm / 80 in-lb

M40103 - 09/11 - Subject to change. © Belimo Aircontrols (USA), Inc.

Determining Torque Loading and Actuator Sizing

Damper torque loadings, used in selecting the correct size actuator, should be provided by the damper manufacturer. If this information is not available, the following general selection guidelines can be used.

Damper Type	Torque Loading
Opposed blade, without edge seals, for non-tight close-off applications	3 in-lb/sq. ft.
Parallel blade, without edge seals, for non-tight close-off applications	4 in-lb/sq. ft.
Opposed blade, with edge seals, for tight close-off applications	5 in-lb/sq. ft.
Parallel blade, with edge seals, for tight close-off applications	7 in-lb/sq. ft.

The above torque loadings will work for most applications with 1000 FPM face velocity. For applications between this criteria and 2500 FPM, the torque loading should be increased by a multiplier of 1.5. If the application calls for higher criteria up to 3000 FPM, use a multiplier of 2.0.

Torque Loading Chart

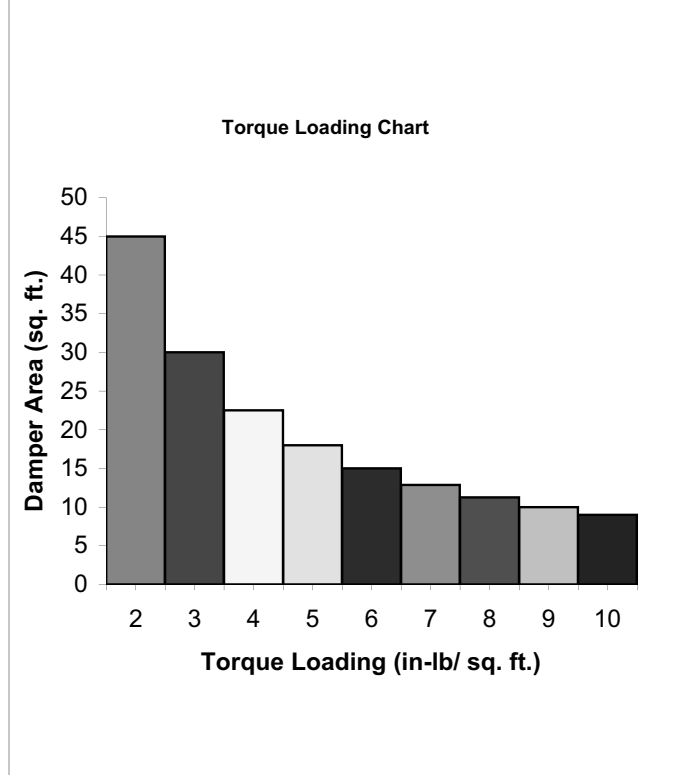

General Information

Belimo actuators should be mounted indoors in a dry, relatively clean environment free from corrosive fumes. If the actuator is to be mounted outdoors, a protective enclosure must be used to shield the actuator.

For new construction work, **order dampers with extended shafts**. Instruct the installing contractor to allow space for mounting and service of the Belimo actuator on the shaft. The damper shaft must extend at least 3 1/2" from the duct. If the shaft extends less than 3-1/2" or if an obstruction blocks access, the shaft can be extended with the AV 8-25 shaft extension accessory or the actuator may be mounted in its short shaft configuration.

Mechanical Operation

The actuator is mounted directly to a damper shaft up to 1.05" in diameter by means of its universal clamp. A crank arm and several mounting brackets are available for applications where the actuator cannot be direct coupled to the damper shaft. The NFB, NFX series actuators provide true spring return operation for reliable fail-safe application and positive close-off on air tight dampers. The spring return system provides constant torque to the damper with, and without, power applied to the actuator. The NFB...-S, NFX...-S versions are provided with two built-in auxiliary switches. These SPDT switches are provided for safety interfacing or signaling, for example, for fan start-up. The switching function at the fail-safe position is fixed at +10°, the other switch function is adjustable between +10° to +90°.

Automatic Airtight Dampers/Manual Override

The NFB, NFX series provides 95° of rotation and is provided with a graduated position indicator showing 0° to 95°.

The NFB, NFX has a unique built in manual positioning mechanism which allows the setting of any damper position within its 95° of rotation. A pre-tensioned spring automatically tightens the damper when power is applied to the actuator, compensating for damper seal deterioration.

The actuator is shipped at +5° (5° from full fail-safe) to provide automatic compression against damper gaskets for tight shut-off. When power is applied, the manual mechanism is released and the actuator drives toward the full fail-safe position.

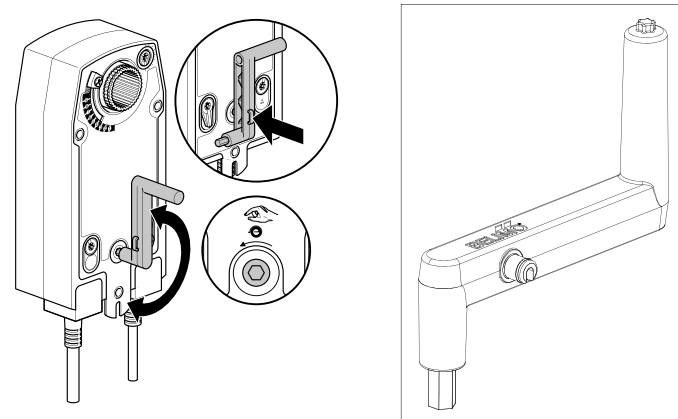

Standard Mounting

NOTE: The NFB, NFX...series actuator is shipped with the manual override adjusted for a +5° position at the universal clamp (not at full fail-safe, 0°). This allows for automatic compression of damper blade seals when the actuator is in use, providing tight shut-off. This assumes that the damper is to have tight shut-off at the fail-safe position. If tight close-off is desired at the opposite direction from fail-safe, the manual override should be released so the actuator can go to the full fail-safe position. See the manual override instructions.

1. Manually move the damper to the fail-safe position (usually closed). If the shaft rotated counterclockwise (↺), this is a CCW installation. If the shaft rotated clockwise (↻), this is a CW installation. In a CCW installation, the actuator side marked "CCW" faces out, while in a CW installation, the side marked "CW" faces out. All other steps are identical.
2. The actuator is usually shipped with the universal clamp mounted to the "CCW" side of the actuator. To test for adequate shaft length, slide the actuator over the shaft with the side marked "CCW" (or the "CW" side if this is the side with the clamp). If the shaft extends at least 1/8" through the clamp, mount the actuator as follows. If not, go to the *Short Shaft Installation* section.
3. If the clamp is not on the correct side as determined in step #1, re-mount the clamp as follows. If it is on the correct side, proceed to step #5. Look at the

universal clamp. If you are mounting the actuator with the "CCW" side out, position the clamp so that the pointer section of the tab is pointing to 0° (see Figure C) and the spline pattern of the clamp mates with spline of the actuator. Slip the clamp over the spline. (Use the same procedure if the "CW" side is out.) If your application requires a mechanical minimum position, read the *Rotation Limiting, Mechanical Minimum Damper Position* section.

4. Lock the clamp to the actuator using the retaining clip.
5. Verify that the damper is still in its full fail-safe position.
6. Slide the actuator over the shaft.
7. Position the actuator in the desired location.
8. Tighten the two nuts on the clamp using a 10mm wrench or socket using 6-8 ft-lb of torque.
9. Slip the stud of the anti rotation strap into the slot at the base of the actuator. The stud should be positioned approximately 1/16 of an inch from the closed end of the slot. Bend the strap as needed to reach the duct. Attach the strap to the duct with #8 self tapping screws.

Short Shaft Installation

If the shaft extends at least 3/4" from the duct, follow these steps:

1. Determine the best orientation for the universal clamp on the back of the actuator. The best location would be where you have the easiest access to the V bolt nuts on the clamp.
2. Engage the clamp to the actuator as close as possible to the determined location.
3. Lock the clamp in place using the remaining retainer clip.
4. Verify that the damper is still in its full fail-safe position.
5. Slide the actuator over the shaft.
6. Position the actuator in the desired location.
7. Tighten the two nuts on the clamp using a 10mm wrench or socket using 6-8 ft-lb of torque.
8. Slip the stud of the anti-rotation strap into the slot at the base of the actuator. The stud should be positioned approximately 1/16 of an inch from the closed end of the slot. Bend the strap as needed to reach the duct. Attach the strap to the duct with #8 self tapping screws.
9. If damper position indication is required, use the optional IND-AFB pointer. See **Figure A**.

Jackshaft Installation

The NFB, NFX... series actuator is designed for use with jackshafts up to 1.05" in diameter. In most applications, the NFB, NFX actuator may be mounted in the same manner as a standard damper shaft application. If more torque is required than one NFB, NFX actuator can provide, refer to AFB, AFX or AF series actuators.

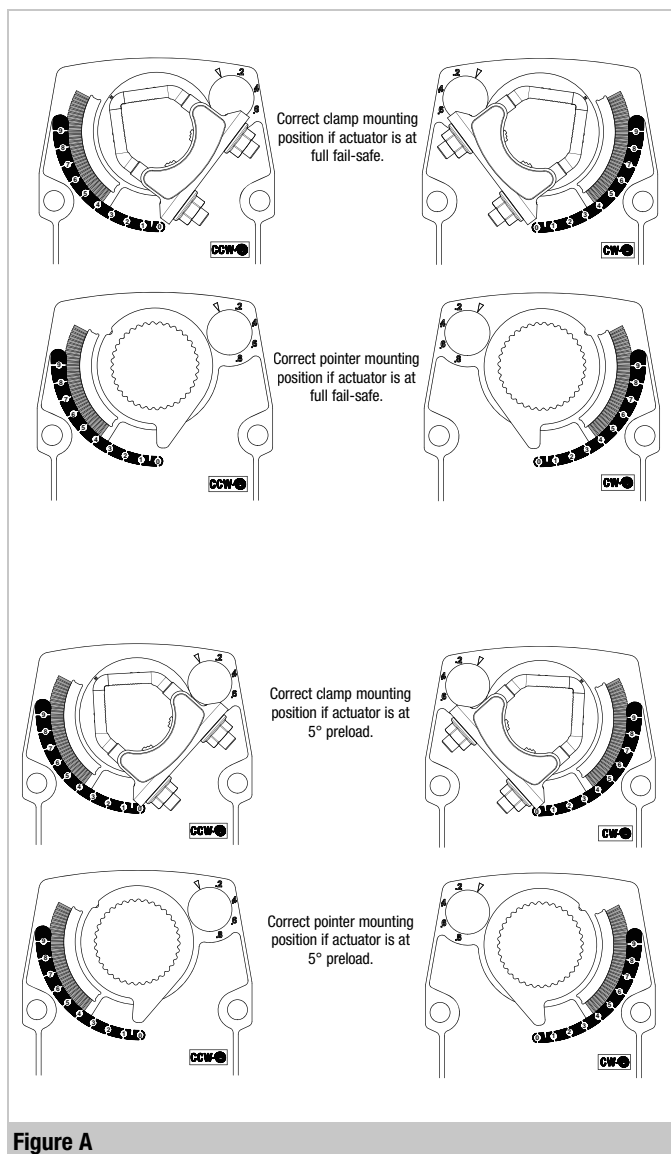

Figure A

Rotation Limitation

The angle of rotation limiter, which is built into the actuator, is used in conjunction with the tab on the universal clamp or IND-AFB position indicator. In order to function properly, the clamp or indicator must be mounted correctly.

See **Figure A**.

The rotation limiter may not work in certain mounting orientations using the ZG-118 mounting bracket. Limiting the damper rotation must be accomplished by adjusting the crank arm linkage.

The built-in rotation limiter may be used in 2 ways to control the rotational output of the NFB, NFX series actuator. One use is in the application where a damper has a designed rotation less than 90°. An example would be a 45° or 60° rotating damper. The other application would be to set a minimum damper position which can be easily set or changed without having to remove the actuator from the damper.

Damper Rotation Limiting

1. Determine the amount of damper rotation required.
2. Locate the Angle of Rotation Limiter on the actuator **Figure B**.
3. Position the limiter to the desired position, making sure the locating “teeth” on the limiter are engaged into the locating holes on the actuator.
4. Fasten the limiter by screwing the attached screw.
5. Test the damper rotation either manually with the manual crank or apply power and if required, a control signal. Re-adjust if necessary.

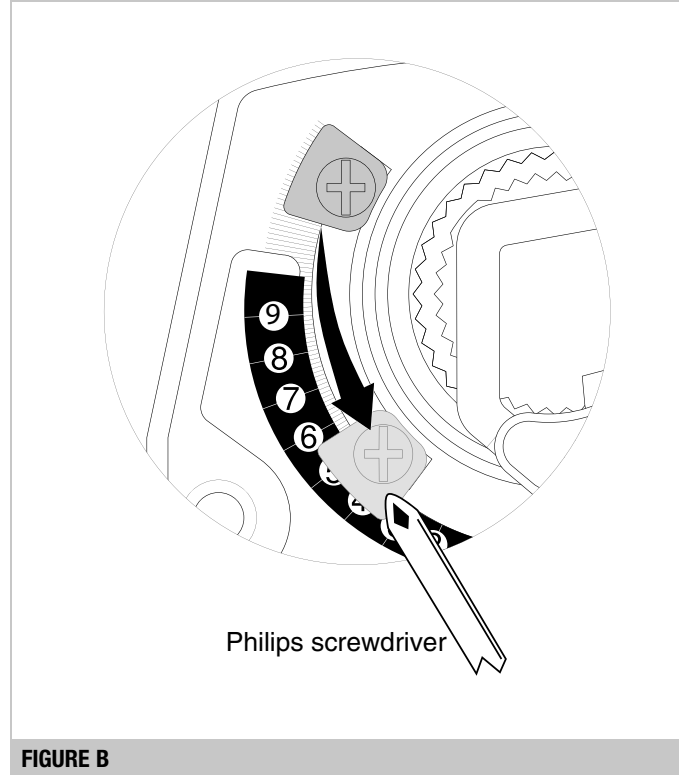
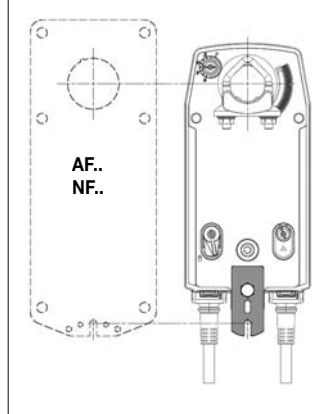
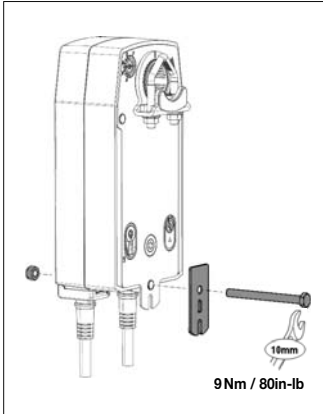

FIGURE B

Z-AF For Replacing AF and NF Actuators



Manual Override

The NFB, NFX series actuators can be manually positioned to ease installation or for emergency positioning.

1. The manual override will only work if no power is available to the actuator.
2. Insert the manual crank (shipped with the actuator) into the hexagon hole located on either side of the actuator. An illustration, located on the label, shows the location.
3. Turn the crank in the direction shown on the label (clockwise on the "CW" side, counterclockwise on the "CCW" side). It will take approximately 23 revolutions to rotate the full 95° of rotation.
4. To lock the actuator in the required position, flip the switch to the locked position that is located to the right of the crank on the CCW side of the actuator (left of the crank on the CW side).
5. The manual override may be disengaged in 2 ways.
 - Flip the switch to the unlocked position and the actuator will go to its fail-safe position.
 - Apply power to wire 1 and 2. The actuator will automatically disengage the override function and will go to the "on" position in the case of the On/Off versions. Or, in the case of the proportional versions, go to the 0 signal position and then go to the position corresponding to the control signal. The actuator will now work normally.

CCW Side Example:

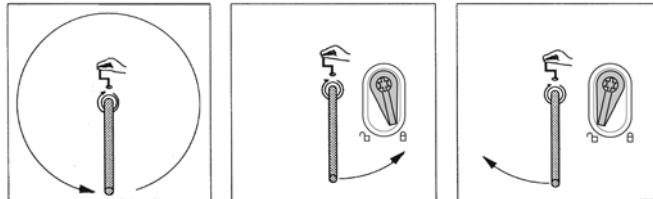

Winding the damper actuator

- insert crank handle
- turn handle in direction of arrow

Locking the damper actuator

- Flip the lock switch to the position pointing to the "locked" symbol

Unlocking the damper actuator (2 options)

- Flip the lock switch to the position pointing to the "unlocked" symbol.
- Remote control by supplying power to the unit for > than 3 sec.

Testing the installation Without Power

The actuator/damper installation may be tested without power at the actuator. Refer to the manual positioning section of the instructions. Move the damper to its full non-fail-safe position using the manual crank. Disengage the manual position mechanism and have the damper go to full fail-safe position. Correct any mechanical problems and retest.

Auxiliary Switches

The NFB, NFX series actuators may be ordered with 2 built-in SPDT auxiliary switches used for safety interfacing or signaling, for example, for fan start-up. The switch position near the fail-safe position is fixed at 10°. The other is adjustable between 10° and 90° of rotation. The crank that is supplied with the actuator is used to change the switch position.

SWITCH RATING

Voltage	Resistive Load	Inductive Load
120 VAC	3A	1.03A
250 VAC	3A	0.5A

Two methods may be used to adjust the switching point of the adjustable switch.

Method 1 - See Figure F

1. The actuator must be in its fail-safe position.
2. Insert the crank handle into the torx shaped hole located in the center of the adjustable switch pointer.
3. Gently rotate the crank until the switch pointer is at the desired switch point in degrees as shown.

NFB, NFX... Series

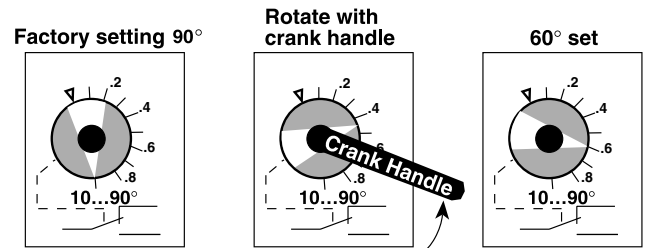

FIGURE F

Method 2 - See Figure G

1. Position the damper to the point at which you want the switch to activate. This may be done by using the manual override or by providing the appropriate proportional signal to NFB24, NFX24... modulating type actuator. The position of the switch pointer is not important during this step
2. Insert the crank into the torx shaped hole located in the center of the adjustable switch pointer.
3. Gently rotate the switch pointer to just past the switch point indicating arrow as shown.

NFB, NFX... Series

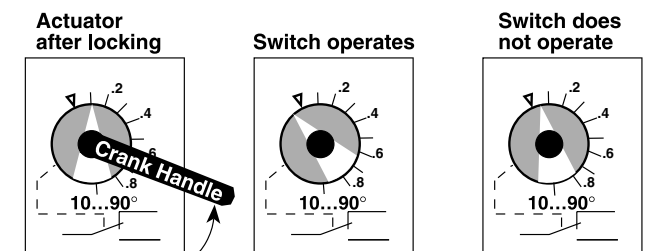

FIGURE G

KH-AFB Crank arm

Including Retaining Ring

CAUTION: The retaining clip supplied with the clamp is **not** used to mount the KH-AFB crank arm.

The KH-AFB crank arm is used in non-direct coupled mounting applications. The KH-AFB may also be used to simultaneously direct couple to a damper shaft and provide an additional crank arm connection to a second damper.

KH-AFB For round shafts up to 3/4" or square shafts up to 5/8"

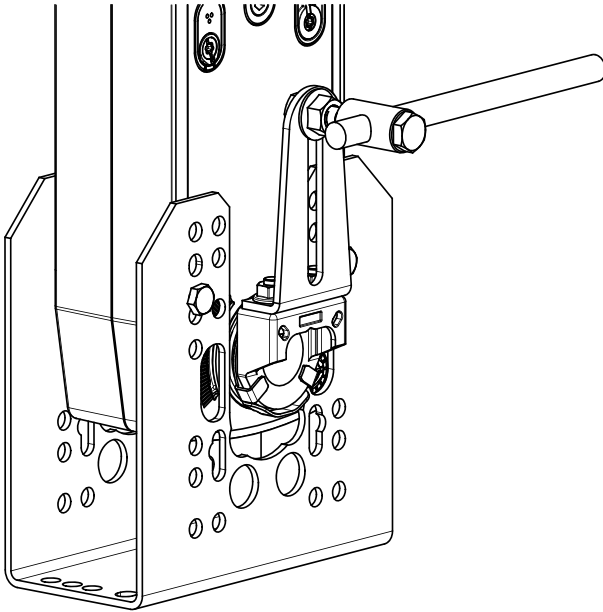
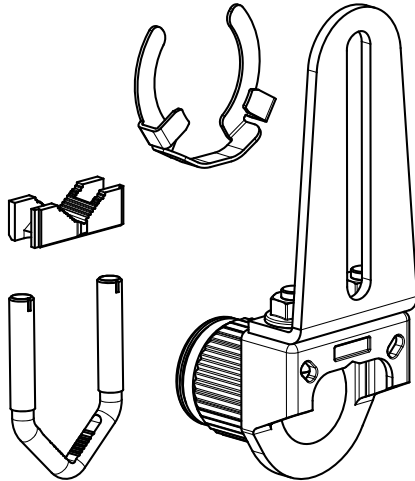

KH-AFB non-direct mounting with ZG-118 mounting bracket

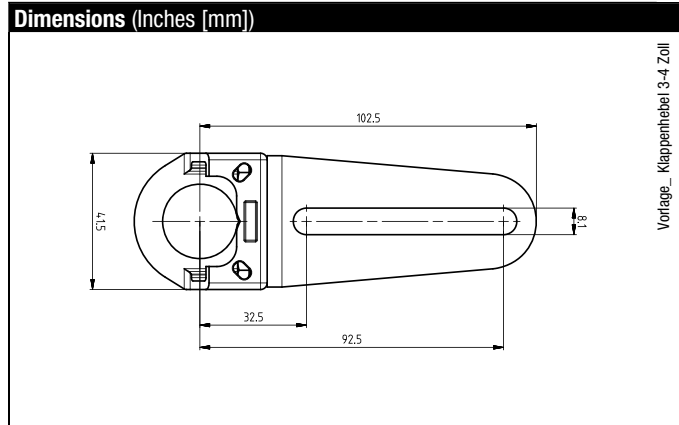

General

The NFB, NFX series actuators utilize both DC Motors and brushless DC motor technology. The NFB, NFX uses this motor in conjunction with an Application Specific Integrated Circuit (ASIC). In the On/Off versions of the NFB and NFX, the ASIC monitors and controls the actuator's rotation and a digital rotation sensing function to prevent damage to the actuator. The NFB24, NFX24... modulates type actuators incorporate a built in microprocessor. The microprocessor provides the intelligence to the ASIC to provide a constant rotation rate and knows the actuator's exact zero position.

Brushless DC Motor Operation

Belimo's brushless DC motor spins by reversing the poles of stationary electromagnets housed inside of a rotating permanent magnet. The electromagnetic poles are switched by a special ASIC circuit developed by Belimo. Unlike the conventional DC motor, there are no brushes to wear or commutators to foul.

Overload Protection

The NFB, NFX series actuators are protected from overload at all angles of rotation. The ASIC circuit constantly monitors the rotation of the DC motor inside the actuator and stops the pulses to the motor when it senses a stall condition. The DC motor remains energized and produces full rated torque to the load. This helps ensure that dampers are fully closed and that edge and blade seals are always properly compressed.

Motor Position Detection

Belimo brushless DC motors eliminate the need for potentiometers for positioning in modulating type actuators. Inside the motor are three "Hall Effect" sensors. These sensors detect the spinning rotor and send pulses to the microprocessor which counts the pulses and calculates the position to within 1/3 of a revolution of the motor.

Control Accuracy and Stability

-SR and MFT NF actuators have built-in brushless DC motors which provide better accuracy and longer service life.

The NFB24-MFT, NFX24-MFT actuators are designed with a unique non-symmetrical deadband. The actuator follows an increasing or decreasing control signal with a 80 mV resolution. If the signal changes in the opposite direction, the actuator will not respond until the control signal changes by 200 mV. This allows these actuators to track even the slightest deviation very accurately, yet allowing the actuator to "wait" for a much larger change in control signal due to control signal instability.

NF Actuator responds to an 80 mV signal when not changing direction from stop

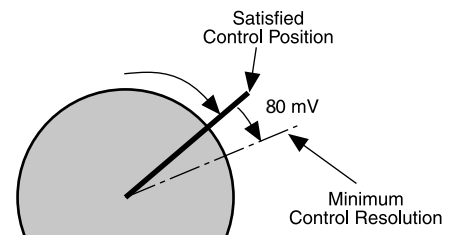

NF Actuator responds to a 200 mV signal when reversing direction from stop position.

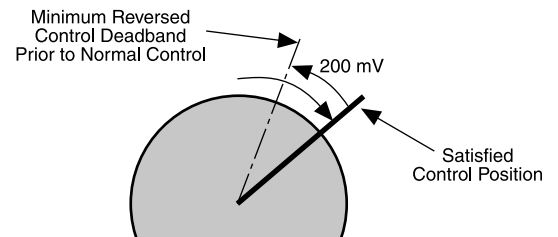

Note: Resolution is a percentage of operating range. 1% in one direction, 2.5% when changing direction. 2-10 VDC control example shown above.

Installation Instructions

General Wiring Instructions



WARNING The wiring technician must be trained and experienced with electronic circuits. Disconnect power supply before attempting any wiring connections or changes. Make all connections in accordance with wiring diagrams and follow all applicable local and national codes. Provide disconnect and overload protection as required. Use copper, twisted pair, conductors only. If using electrical conduit, the attachment to the actuator must be made with flexible conduit.

Always read the controller manufacturer's installation literature carefully before making any connections. Follow all instructions in this literature. If you have any questions, contact the controller manufacturer and/or Belimo.

Transformers

The NFB24, NFX24...actuators require a 24 VAC class 2 transformer and draws a maximum of 10 VA per actuator. The actuator enclosure cannot be opened in the field, there are no parts or components to be replaced or repaired.

- EMC directive: 2004/108/EC
- Software class A: Mode of operation type 1
- Low voltage directive: 2006/95/EC

CAUTION: It is good practice to power electronic or digital controllers from a separate power transformer than that used for actuators or other end devices. The power supply design in our actuators and other end devices use half wave rectification. Some controllers use full wave rectification. When these two different types of power supplies are connected to the same power transformer and the DC commons are connected together, a short circuit is created across one of the diodes in the full wave power supply, damaging the controller. Only use a single power transformer to power the controller and actuator if you know the controller power supply uses half wave rectification.

Multiple Actuators, One Transformer

Multiple actuators may be powered from one transformer provided the following rules are followed:

1. The TOTAL current draw of the actuators (VA rating) is less than or equal to the rating of the transformer.
2. Polarity on the secondary of the transformer is strictly followed. *This means that all No. 1 wires from all actuators are connected to the common leg on the transformer and all No. 2 wires from all actuators are connected to the hotleg.* Mixing wire No. 1 & 2 on one leg of the transformer will result in erratic operation or failure of the actuator and/or controls.

Multiple Actuators, Multiple Transformers

Multiple actuators positioned by the same control signal may be powered from multiple transformers provided the following rules are followed:

1. The transformers are properly sized.
2. All No. 1 wires from all actuators are tied together and tied to the negative leg of the control signal. See wiring diagram.

Wire Length for NFB..., NFX... Actuators

Keep power wire runs below the lengths listed in the **Figure H**. If more than one actuator is powered from the same wire run, divide the allowable wire length by the number of actuators to determine the maximum run to any single actuator.

Example: 3 actuators, 16 Ga wire
 $350 \text{ Ft} \div 3 \text{ Actuators} = 117 \text{ Ft. Maximum wire run}$

MAXIMUM WIRE LENGTH FOR 10VA			
Wire Size	Max. Feet.	Wire Size	Max. Feet
12 Ga	900 Ft.	18 Ga	220 Ft.
14 Ga	550 Ft.	20 Ga	120 Ft.
16 Ga	350 Ft.	22 Ga	60 Ft.

FIGURE H

Wire Type and Wire Installation Tips

For most installations, 18 or 16 Ga. cable works well with the NFB24, NFX24...actuators. Use code-approved wire nuts, terminal strips or solderless connectors where wires are joined. It is good practice to run control wires unspliced from the actuator to the controller. If splices are unavoidable, make sure the splice can be reached for possible maintenance. Tape and/or wire-tie the splice to reduce the possibility of the splice being inadvertently pulled apart.

The NFB24, NFX24... proportional actuators have a digital circuit that is designed to ignore most unwanted input signals (pickup). In some situations the pickup may be severe enough to cause erratic running of the actuator. For example, a large inductive load (high voltage AC wires, motors, etc.) running near the power or control wiring may cause excessive pickup. To solve this problem, make one or more of the following changes:

1. Run the wire in metallic conduit.
2. Re-route the wiring away from the source of pickup.
3. Use shielded wire (Belden 8760 or equal). Ground the shield to an earth ground. **Do not** connect it to the actuator common.

Initialization of the NFB24-MFT, NFX24-MFT

When power is initially applied, the actuator will first release its manual preload position (This assumes a manual position has been set). The actuator will then rotate to the full fail-safe position. At this point the microprocessor recognizes that the actuator is at full fail-safe and uses this position as the base for all of its position calculations. The microprocessor will retain the initialized zero during short power failures of up to 20 seconds. The NFB24-MFT and NFX24-MFT will also return to its position prior to the 20-second-or-less power loss. For power failures greater than 20 seconds, the actuator would naturally return to its full fail-safe position prior to the microprocessor losing its memory. The actuator will also re-initialize if the manual position mechanism is used.

NFB24-MFT, NFX24-MFT + P-100... Electrical Check-Out Procedure				
STEP	Procedure	Expected Response	Gives Expected Response Go To Step...	Does Not Give Expected Response Go To Step...
1.	Control signal is applied to actuator.	Actuator will move to its "Control Signal" position.	Actuator operates properly Step 7.	No response at all Step 2. Operation is reversed Step 3. Does not drive toward "Control Signal Position" Step 4.
2.	Check power wiring. Correct any problems. See Note 1.	Power supply rating should be the total power requirement of the actuator(s). Minimum voltage of 19.2 VAC or 21.6 VDC.	Power wiring corrected, actuator begins to drive Step 1.	Power wiring corrected, actuator still does not drive Step 4.
3.	Turn reversing switch to the correct position. Make sure the switch is turned all the way left or right.	Actuator will move to its "Control Signal" position.	Actuator operates properly Step 7.	Does not drive toward "Control Signal Position" Step 4.
4.	Make sure the control signal positive (+) is connected to Wire No. 3 and control signal negative (-) is connected to wire No. 1. Most control problems are caused by reversing these two wires. Verify that the reversing switch is all the way CCW or CW.	Drives to "Control Signal" position.	Actuator operates properly Step 7.	Step 5.
5.	Check input signal with a digital volt meter (DVM). Make sure the input is within the range of the actuator. NOTE: The input signal must be above the 2 VDC or 4 mA to have the actuator move.	Input voltage or current should be $\pm 1\%$ of what controller's adjustment or programming indicates.	Controller output (actuator input) is correct. Input Polarity Correct Step 6.	Reprogram, adjust repair or replace controller as needed Step 1.
6.	Check damper torque requirement.	Torque requirement is actuator's minimum torque.	Defective Actuator. Replace Actuator - See Note 2.	Recalculate actuator requirement and correct installation.
7.	Actuator works properly. Test controller by following controller manufacturer's instructions.			

- NOTE 1** Check that the transformer(s) are sized properly.
- If a common transformer is used, make sure that polarity is observed on the secondary. This means connect all No. 1 wires to one leg of the transformer and all No. 2 wires to the other leg of the transformer.
 - If multiple transformers are used with one control signal, make sure all No. 1 wires are tied together and tied to control signal negative (-).
 - Controllers and actuators must have separate 24 VAC/VDC power sources.
- NOTE 2** If failure occurs within 5 years from original purchase date, notify Belimo and give details of the application.

M40103 - 09/11 - Subject to change. © Belimo Aircontrols (USA), Inc.