

Electric Spring Return Actuators

Description

The M9220-xxx-3 Series Actuators are direct mount, spring return electric actuators that operate with these available power options:

- AC 24 V at 50/60 Hz or DC 24 V (AGx, BGx, GGx, HGx)
- AC 120 V at 60 Hz (BAx)
- AC 230 V at 50/60 Hz (BDx)

These bidirectional actuators do not require a damper linkage, and are easily installed on dampers with 1/2 to 3/4 in. or 12 to 19 mm round shafts, or 3/8 and 1/2 in. or 10, 12, and 14 mm square shafts using the standard shaft clamp included with the actuator. An optional M9220-600 Jackshaft Coupler Kit is available for 3/4 to 1-1/16 in. or 19 to 27 mm round shafts, or 5/8 and 3/4 in. or 16, 18, and 19 mm square shafts.

A single M9220-xxx-3 Series Electric Spring Return Actuator provides a running and spring return torque of 177 lb-in (20 N·m). Two or three models mounted in tandem deliver twice or triple the torque. Integral line voltage auxiliary switches are available on the xxC models to indicate end-stop position, or to perform switching functions within the selected rotation range. Refer to the *M9220-xxx-3 Series Electric Spring Return Actuators Product Bulletin (LIT-12011057)* for important product application information.

Repair Information

If the M9220 Electric Actuator fails to operate within its specifications, replace the unit. For a replacement actuator, contact the nearest Johnson Controls® representative.

Features

- simple direct coupling reduces installation and commissioning time while improving reliability by eliminating damper linkages
- reversible mounting design enables the actuator to spring return in either direction
- removable coupler adapts to a shorter damper shaft
- electronic stall detection throughout entire rotation range extends the life of the actuator by deactivating the actuator motor when an overload condition is detected
- integral 48 in. (1.2 m) halogen-free cables with colored and numbered conductors simplify field wiring
- integral auxiliary switches (xxC Models) provide one fixed and one adjustable switch point with line voltage capability
- NEMA 2 (IP54) rated aluminum enclosure protects the internal components of the actuator from dirt and moisture
- easy-to-use locking manual override with auto release and crank storage allows for manual positioning of the actuator hub
- integral connectors for 3/8 in. flexible metal conduit simplifies installation and field wiring

Applications

The M9220-xxx-3 Series Electric Spring Return Actuators provide reliable control of dampers and valves in Heating, Ventilating, and Air Conditioning (HVAC) Systems. The M9220-xxx-3 Series Actuators are available for use with on/off, floating, and proportional controllers.



M9220 Series Electric Spring Return Actuator

hvacUSA.com
 A MechTronics Controls Company
www.hvacusa.com
 Phone (877) 632-4876

Selection Charts

M9220 Series Electric Spring Return Actuators

Code Number	Control Type	Torque / Voltage / Timing	Auxiliary Switches	Comments
M9220-AGA-3	On-Off, Floating	AC 24 V 50/60 Hz 177 lb-in (20 Nm) 150 Seconds	None	48 in. (1.2 m) Halogen-Free Cable with 18 AWG (0.75 mm ²) Wire Leads
M9220-AGC-3			2-SPDT	
M9220-BAA-3	On-Off	AC 120 V 60 Hz 177 lb-in (20 Nm) 24 to 57 Seconds	None	
M9220-BAC-3			2-SPDT	
M9220-BDA-3	On-Off	AC 230 V 50/60 Hz 177 lb-in (20 Nm) 24 to 57 Seconds	None	
M9220-BDC-3			2-SPDT	
M9220-BGA-3	On-Off	AC 24 V 50/60 Hz 177 lb-in (20 Nm) 24 to 57 Seconds	None	
M9220-BGC-3			2-SPDT	
M9220-GGA-3	DC 0(2)...10 V Proportional	AC 24 V 50/60 Hz 177 lb-in (20 Nm) 150 Seconds	None	
M9220-GGC-3			2-SPDT	
M9220-HGA-3	DC 0...20 V with Programmable Start and Span		None	
M9220-HGC-3			2-SPDT	

M9220 Series Electric Spring Return Actuators (Continued)

Accessories for M9220 Series Electric Actuators

Code Number	Description
DMPR-KR003 ¹	Sleeve Pin Kit for Johnson Controls round dampers with a 5/16 in. (8 mm) diameter shaft
DMPR-KC003 ¹	Square Head Blade Pin Extension without Bracket for Johnson Controls CD-1300 direct-mount applications
DMPR-KC011	Hex Head Blade Pin Extension without Bracket
DMPR-KC012	Hex Head Blade Pin Extension with Bracket
DMPR-KC210	Damper Jackshaft 1" Diameter, 1 Panel
DMPR-KC211	Damper Jackshaft 1" Diameter, 2 Panel
DMPR-KC212	Damper Jackshaft 1" Diameter, 3 Panel
DMPR-KC213	Damper Jackshaft ½" Diameter, 1 Panel
DMPR-KC214	Damper Jackshaft ½" Diameter, 2 Panel
M9000-519	Valve Linkage Kit for mounting M9220 actuators to 2-1/2 in. to 4 in. VG1xA5 Series flange body ball valves.
M9000-153	Crank Arm
M9000-170	Remote Mounting Kit, Horizontal. Kit includes Mounting Bracket, M9000-153 Crank Arm, Ball Joint, and Mounting Bolts.
M9000-171	Remote Mounting Kit, Vertical. Kit includes Mounting Bracket, M9000-153 Crank Arm, Ball Joint, and Mounting Bolts.
M9000-200	Commissioning Tool provides a control signal to drive on/off, floating, proportional, or resistive actuators.
M9000-53x	Valve Linkage Kit for mounting M9220 actuators to 2-1/2 to 6 in. VG2000 Series globe valves
M9000-604	Replacement Anti-rotation Bracket Kit (with Screws) for M9220-xxx-3 Series Proportional Electric Spring Return Actuators
M9220-600	1 in. (25 mm) Jackshaft Coupler Kit (with Locking Clip) for Mounting M9220-xxx-3 Series Proportional Electric Spring Return Actuators on Dampers with 3/4 to 1-1/16 in. or 19 to 27 mm Round Shafts, or 5/8 and 3/4 in. or 16, 18, and 19 mm Square Shafts
M9220-601	Replacement Coupler Kit (with Locking Clip) for Mounting M9220-xxx-3 Series Proportional Electric Spring Return Actuators on Dampers with 1/2 to 3/4 in. or 12 to 19 mm Round Shafts, or 3/8 and 1/2 in. or 10, 12, and 14 mm Square Shafts
M9220-602	Replacement Locking Clips for M9220-xxx-3 Series Proportional Electric Spring Return Actuators (Five per Bag)
M9220-603	Adjustable Stop Kit for M9220-xxx-3 Series Proportional Electric Spring Return Actuators
M9220-604	Replacement Manual Override Cranks for M9220-xxx-3 Series Proportional Electric Spring Return Actuators (Five per Bag)
M9220-610	Replacement Shaft Gripper, 10 mm Square Shaft with Locking Clip
M9220-612	Replacement Shaft Gripper, 12 mm Square Shaft with Locking Clip
M9220-614	Replacement Shaft Gripper, 14 mm Square Shaft with Locking Clip

1. Furnished with the damper and may be ordered separately.

Technical Specifications

M9220 Series Electric Spring Return Actuators (Part 1 of 2)		
Power Requirements	AGx, GGx, and HGx:	AC 24 V (AC 19.2...30 V) at 50/60 Hz: Class 2, 15.6 VA Running, 7.7 VA Holding Position; DC 24 V (DC 21.6...26.4 V): Class 2, 7.5 W Running, 2.9 W Holding Position
	BAx:	Nominal AC 120 V at 60 Hz: 0.25 A Running, 0.13 A Holding Position
	BDx:	Nominal AC 230 V at 50/60 Hz: 0.15 A Running, 0.09 A Holding Position
	BGx:	AC 24 V (AC 19.2...30 V) at 50/60 Hz: Class 2, 24.6 VA Running, 7.7 VA Holding Position; DC 24 V (DC 21.6...26.4 V): Class 2, 17.6 W Running, 2.8 W Holding Position
Transformer Sizing Requirements	AGx, GGx, and HGx:	20 VA Minimum per Actuator
	BGx:	25 VA Minimum per Actuator
Control Type	AGx:	On-Off, and Floating
	Bxx:	On-Off
	GGx:	DC 0(2)...10 VDC or DC 0(4)...20 mA proportional with external 500 Ohm resistor
	HGx:	DC 0...10 VDC or DC 0...20 mA proportional with adjustable start and span
Input Signal	AGx:	AC 24 V at 50/60 Hz or DC 24 V
	BAx:	AC 120 V at 60 Hz
	BDx:	AC 230 V at 50/60 Hz
	BGx:	AC 24 V at 50/60 Hz
	GGx	DC 0(2)...10 V or DC 0(4)...20 mA with 500 ohm resistor
	HGx:	DC 0...20 V
Input Signal Adjustments	AGx:	Switch Selectable Direct or Reverse Action
	GGx:	Factory Set at DC 0(2)...10 V, CW Rotation with Signal Increase; Selectable DC 0(2)...10 V or DC 0(4)...20 mA with Field Furnished 500 ohm, 0.25 W minimum resistor; Switch Selectable Direct or Reverse Action with Signal Increase
	HGx:	Factory Set DC 0...10 V, CW Rotation with Signal Increase; Selectable DC 0...10 V or DC 0...20 mA with Field Furnished 500 ohm, 0.25 W minimum resistor; Start Point Programmable DC 0...10 V; Span Programmable DC 2...10 V; Switch Selectable Direct or Reverse Action with Signal Increase
Input Impedance	GGx:	Voltage Input: 200,000 ohms;
	HGx:	Current Input: 500 ohms with Field Furnished 500 ohm Resistor

M9220 Series Electric Spring Return Actuators (Continued)

M9220 Series Electric Spring Return Actuators (Part 2 of 2)		
Feedback Signal	GGx:	DC 0(2)...10 V for Desired Rotation Range up to 90°; Corresponds to Rotation Limits, 500 mA maximum
	HGx:	DC 0...20 V for Desired Rotation Range up to 90°; Corresponds to Rotation Limits, 500 mA maximum
Auxiliary Switch Rating	xxC:	Two Single-Pole, Double-Throw (SPDT), Double-Insulated Switches with Gold Flash Contacts: AC 24 V, 50 VA Pilot Duty; AC 120 V, 5.8 A Resistive, 1/4 hp, 275 VA Pilot Duty; AC 240 V, 5.0 A Resistive, 1/4 hp, 275 VA Pilot Duty
Spring Return		Direction is Selectable with Mounting Position of Actuator: Side A, Actuator Face Away from Damper for CCW Spring Return; Side B, Actuator Face Away from Damper for CW Spring Return
Torque Rating	All Models	177 lb-in (20 N·m) for a Single Actuator; 354 lb-in (40 N·m) for Two Models Mounted in Tandem 531 lb-in (60 N·m) for Three Models Mounted in Tandem
Cycle Life	AGx, GGx, and HGx:	60,000 Full Stroke Cycles; 1,500,000 Repositions at Rated Torque
	BGx:	60,000 Full Stroke Cycles at Rated Torque (Maximum Cycle Rate for Life Testing: 15 Cycles Per Hour to Avoid Over Heating the Motor)
Audible Noise Rating AGx, GGx, HGx	Running	<40 dBA at 39-13/32 in. (1 m)
	Holding	<20 dBA at 39-13/32 in. (1 m)
	Spring Return	<55 dBA at 39-13/32 in. (1 m)
Audible Noise Rating Bxx	Running	<66 dBA at 39-13/32 in. (1 m)
	Holding	<18 dBA at 39-13/32 in. (1 m)
	Spring Return	<66 dBA at 39-13/32 in. (1 m)
Rotation Range	All Models	Adjustable from 30 to 90° CW or CCW with Optional M9220-603 Adjustable Stop Kit; Mechanically Limited to 90°
Rotation Time Running	AGx, GGx, and HGx:	150 Seconds for 0 to 177 lb-in (0 to 20 N·m) at All Operating Conditions; Independent of Load
	BGx:	24 to 67 Seconds for 0 to 177 lb-in (0 to 20 N·m) at All Operating Conditions; 35 Seconds Nominal at Full Rated Load
Rotation Time Spring Return	AGx, GGx, and HGx:	20 Seconds for 0 to 177 lb-in (0 to 20 N·m) at Room Temperature
	BGx:	11 to 15 Seconds for 0 to 177 lb-in (0 to 20 N·m) at Room Temperature; 35 Seconds Maximum for 0 to 177 lb-in (0 to 20 N·m) at -22°F (-30°C) 160 Seconds Maximum for 0 to 177 lb-in (0 to 20 N·m) at -40°F (-40°C)
Electrical Connection	Actuator	48 in. (1.2 m) Halogen-Free Cable with 18 AWG (0.75 mm ²) Wire Leads
	Aux Switch	48 in. (1.2 m) Halogen-Free Cable with 18 AWG (0.75 mm ²) Wire Leads
Conduit Connectors		Integral Connectors for 3/8 in. (10 mm) Flexible Metal Conduit
Mechanical Connection	Standard Shaft Clamp Included with Actuator	1/2 to 3/4 in. or 12 to 19 mm Diameter Round Shafts, or 3/8 and 1/2 in. or 10, 12, and 14 mm Square Shafts
	Optional M9220-600 Jackshaft Coupler Kit	3/4 to 1-1/16 in. or 19 to 27 mm Diameter Round Shafts, or 5/8 and 3/4 in. or 16, 18, and 19 mm Square Shafts
Enclosure Rating		NEMA 2 (IP54) for All Mounting Orientations, Aluminum Enclosure
Ambient Operating Rating		-40 to 131°F (-40 to 55°C); 90% RH Maximum, Noncondensing
Ambient Storage Rating		-85 to 185°F (-65 to 85°C); 95% RH Maximum, Noncondensing
Shipping Weight	xGx:	6.4 lb (2.9 kg)
	BAx and BDx:	7.6 lb (3.5 kg)
Agency Compliance	North America	UL Listed, File E27734, CCN XAPX (United States) and XAPX7 (Canada)
	European Union	CE Mark, EMC Directive 89/336/EEC (M9220-xGA-3 Models)
	Australia	C-Tick Mark, Australia/NZ Emissions Compliant (M9220-xGx-3 and M9220-BDx Models)

M9220 Series Electric Spring Return Actuators (Continued)

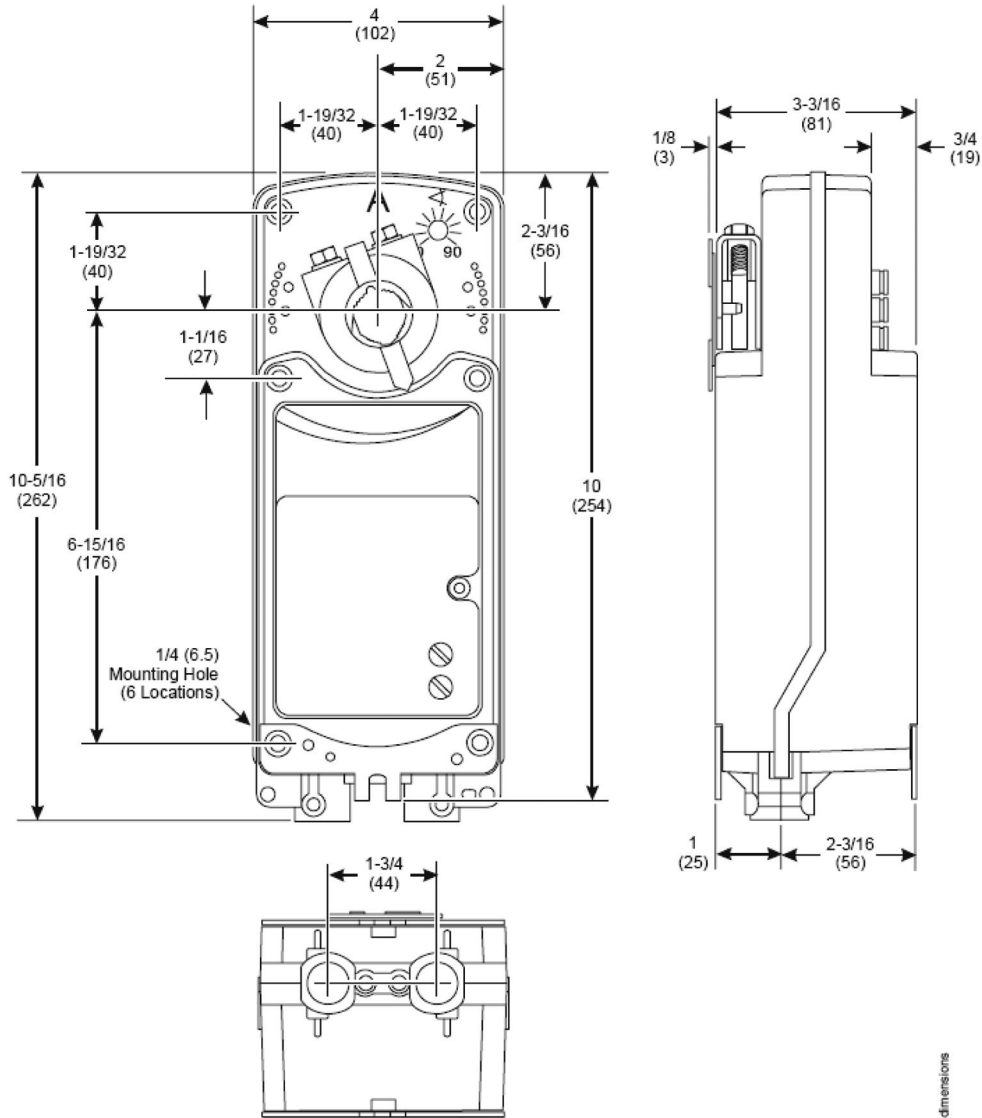

M9220-xxx-3 Series
Electric Spring Return Actuator Dimensions, in. (mm)

dimensions