

General Instructions

APPLICATION

Thermistors offer high accuracy and interchangeability over a wide temperature range. The ET series can be used in the following applications:

- Space
- Duct
- Immersion
- Averaging
- Strap-On
- Bead/Bullet
- Outdoor Air

FEATURES

- Offer high accuracy and interchangeability over a wide temperature range.
- Non-polarity sensitive



ET Series Photo

SPECIFICATIONS

	For TAC Vista, I/NET, Continuum, and I/A	1000 Ohm Platinum	1000 Ohm BALCO
Output	1.8K Ohms @ 77° F (25° C) Vista 10K Ohms @ 77° F (25° C) I/Net 10K Ohms @ 77° F (25° C) Continuum 10K Ohms @ 77° F (25° C) with 11K Ohms shunt resistor I/A	1K Ohms @ 32°F (0°C)	1000 Ohms @ 70°F (21°C)
Temperature Range	-40° to 302° F (-40° to 150° C)	-58° to 392°F (-50 to 200°C) -50° to 275°F (-45.5° to 134.8°C)	-40° to 240°F (-40° to 116°C)
Interchangeability	+/- 0.2 C (0° to 70° C)		
Dissipation Constant Stability	3 mW / C		
Accuracy	+/- 0.2° C (0° to 70° C)	+/- 0.06% @ 32°F (0°C) Single Point +/- 1.0 Ohm @ 70°F (Averaging)	+/- 0.1%
Operating Humidity	0 to 90% RH non-condensing		

DIMENSIONS

Room

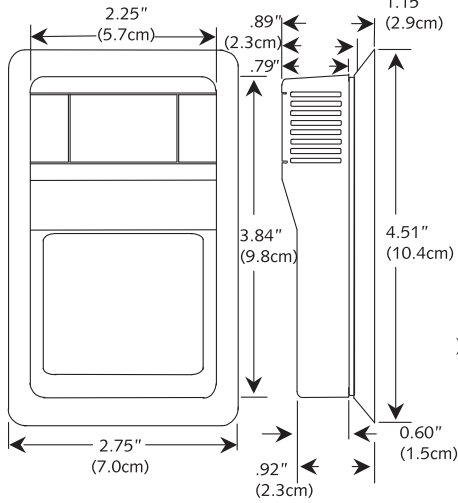

Duct / Averaging

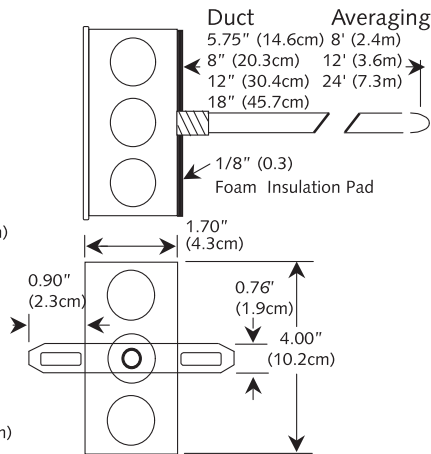

Immersion

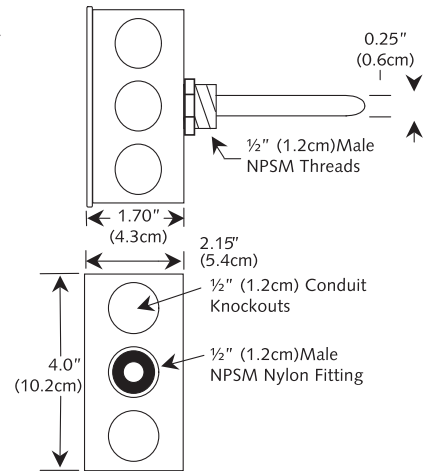

Stainless Plate

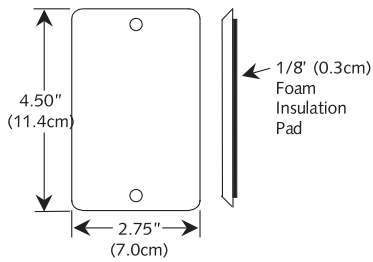

Duct without Box

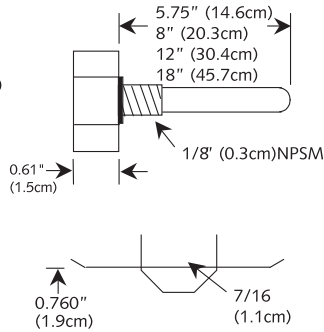

Outside Air

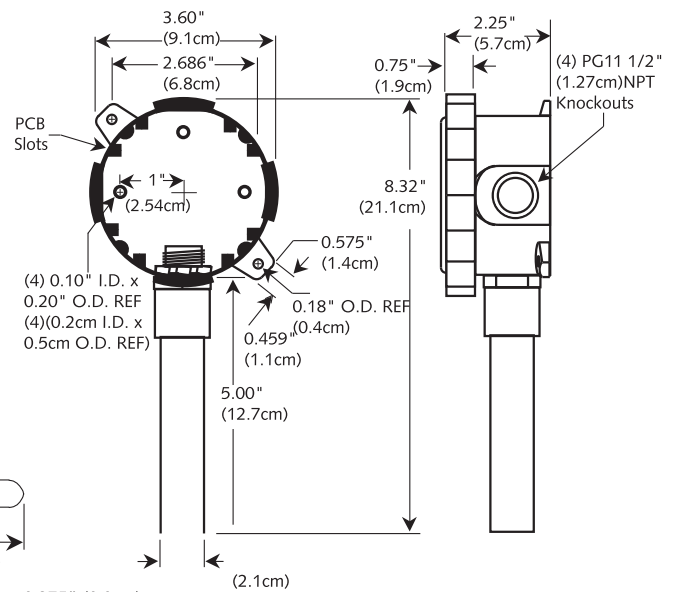

Strap-On

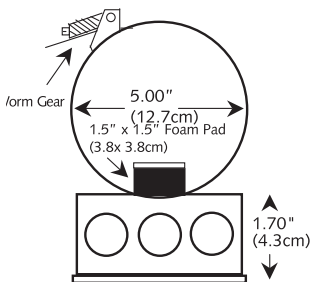

Thermowell

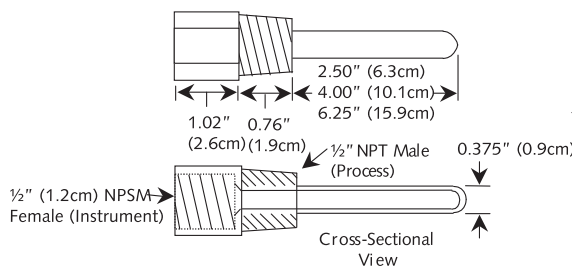

INSTALLATION

ROOM TEMPERATURE SENSORS

This unit is suitable for either drywall mounting or junction box mounting. The room sensor is provided with screw terminal blocks for all connections. Remove the cover from the unit and mount the housing base to the wall using the (2) 6/32" x 1" machine screws. Replace the cover and tighten down, using the (2) 1/16" Allen Screws located on the bottom of the enclosure.

DUCT AND DUCT AVERAGING SENSORS

Duct temperature sensors - drill a 3/8" hole in the duct and insert the probe through the hole until the foam pad is tight to the duct. Now insert (2) screws through the mounting holes in flange and tighten them until the unit is held firmly to the duct. Duct Averaging sensors - Drill a 3/8" hole in the duct and insert the averaging element through the hole until the foam pad is tight to the duct. Now insert the (2) screws through the holes in the mounting flange and tighten until the unit is held firmly to the duct. The sensor should then be strung in a criss-cross pattern throughout the duct using the mounting clips provided, in a pattern that covers the greatest surface area of the duct, to insure that there is no stratification. When bending the copper tubing, be careful that you use a gradual bend and that you DO NOT kink the copper tubing.

IMMERSION TEMPERATURE SENSORS

The TAC Fluid Immersion-type sensors are provided with a 2 1/2", 4", or 6 1/4" insertion length, 304 series stainless steel thermowell. The thermowell has a 1/2" NPT external or process thread and a 1/2" NPT internal or instrument thread. Heat transfer compound may be used but it is not necessary.

STRAP-ON TEMPERATURE SENSORS

The TAC Strap-On sensors, are provided in a NEMA 1 rated junction box with an adjustable 2" to 5" pipe clamp. The unit should be mounted on the bottom side of the pipe to ensure proper heat transfer and a true temperature reading. Heat transfer compound and insulating the sensor will help the overall accuracy of the sensor. By ordering extra straps, and fastening them together, it is possible to make them fit larger pipes.

OUTSIDE AIR TEMPERATURE SENSORS

The TAC Outdoor Air temperature sensors are provided in a weatherproof enclosure. An optional weatherproof Aluminum Bell Box or NEMA 4X Polycarbonate enclosure is also available upon request for an additional charge. All of the mounting hardware is provided with the sensor. Be sure to mount the sensor out of direct sunlight, with the sensor probe pointing downward.

STAINLESS PLATE TEMPERATURE SENSORS

The TAC Stainless Plate temperature sensors are mounted on the back of a 1 Gang stainless steel plate. The foam pad will insulate the sensor from any drafts in the wall. (2) 6/32" x 1" machine screws are provided for junction box mounting. Be sure that the sensor is not mounted on an outside wall, due to the extreme temperature changes from either drafts or heat transfer.

WIRING DIAGRAMS

Diagram for ETR Sensors

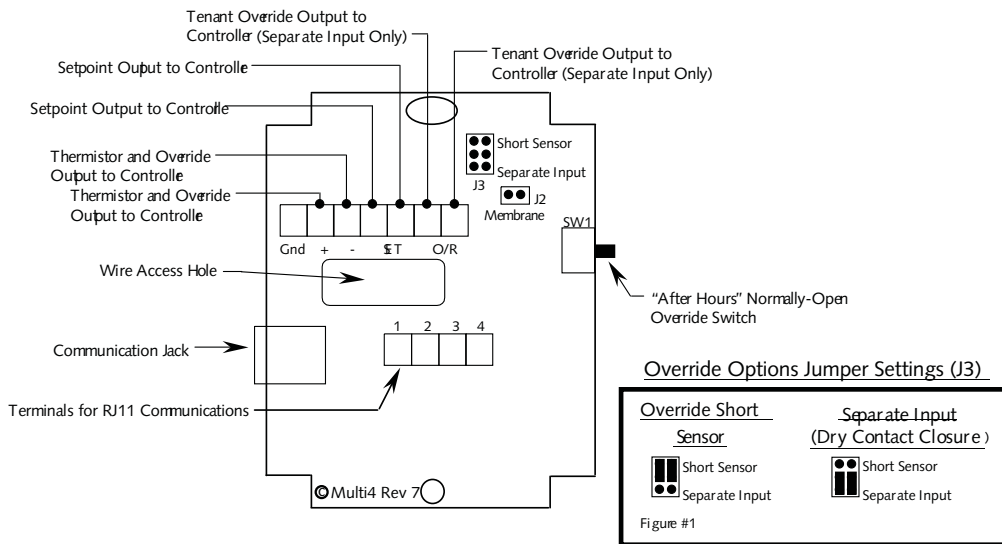
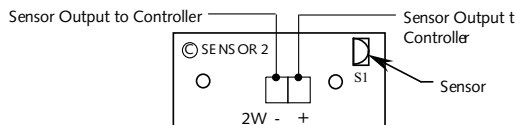

Diagram for ET Sensors Except ETR



ORDERING INFORMATION

Temperature Sensor Description	TAC Vista	I/NET	Continuum	I/A	1000 Ohm Platinum	1000 Ohm BALCO
Room	ETR100	ETR200	ETR500	ETR800	-	-
Room with Setpoint	ETR101	ETR201	ETR501	ETR801	-	-
Room with Override Pushbutton	ETR102	ETR202	ETR502	ETR802	-	-
Room with Setpoint and Override Pushbutton	ETR103	ETR203	ETR503	ETR803	-	-
Wallplate (Stainless Steel)	ETP100	ETP200	ETP500	ETP800		
4" Duct (Galvanized Steel Enclosure)	ETD100-4	ETD200-4	ETD500-4	ETD800-4	ETDPK0-4	ETDBK0-4
6" Duct Galvanized Steel Enclosure)	ETD100-6	ETD200-6	ETD500-6	ETD800-6	ETDPK0-6	ETDBK0-6
8" Duct (Galvanized Steel Enclosure)	ETD100-8	ETD200-8	ETD500-8	ETD800-8	ETDPK0-8	ETDBK0-8
12" Duct (Galvanized Steel Enclosure)	ETD100-12	ETD200-12	ETD500-12	ETD800-12	ETDPK0-12	ETDBK0-12
4" Duct without Enclosure	ETD100-NE-4	ETD200-NE-4	ETD500-NE-4	ETD800-NE-4	ETDPK0-NE-4	ETDBK0-NE-4
6" Duct without Enclosure	ETD100-NE-6	ETD200-NE-6	ETD500-NE-6	ETD800-NE-6	ETDPK0-NE-6	ETDBK0-NE-6
8" Duct without Enclosure	ETD100-NE-8	ETD200-NE-8	ETD500-NE-8	ETD800-NE-8	ETDPK0-NE-8	ETDBK0-NE-8
12" Duct without Enclosure	ETD100-NE-12	ETD200-NE-12	ETD500-NE-12	ETD800-NE-12	ETDPK0-NE-12	ETDBK0-NE-12
2" Immersion (Galvanized Steel Enclosure)	ETI100-2	ETI200-2	ETI500-2	ETI800-2	ETIPK0-2	ETIBK0-2
4" Immersion (Galvanized Steel Enclosure)	ETI100-4	ETI200-4	ETI500-4	ETI800-4	ETIPK0-4	ETIBK0-4
6" Immersion (Galvanized Steel Enclosure)	ETI100-6	ETI200-6	ETI500-6	ETI800-6	ETIPK0-6	ETIBK0-6
8' Averaging (Flexible Copper)	ETA100-8	ETA200-8	ETA500-8	ETA800-8	-	-
12' Averaging (Flexible Copper)	ETA100-12	ETA200-12	ETA500-12	ETA800-12	ETAPK0-12	ETABK0-12
24' Averaging (Flexible Copper)	ETA100-24	ETA200-24	ETA500-24	ETA800-24	ETAPK0-24	ETABK0-24
Outside Air	ETO100	ETO200	ETO500	ETO800	-	-
Strap On	ETS100	ETS200	ETS500	ETS800	-	-
Bead / Bullet	ETB100	ETB200	ETB500	ETB800	-	-

Miscellaneous Options	Code
LCD Display (for room units only)	-LCD
LED Indicator (for room units with override only)	-LED
Thermometer Indicator (for room units only)	-TI
RS232 Communication Jack (for use with I/NET systems only)	-RS232
Four-Pin RJ11 Communication Jack (for use with TAC Vista and Continuum systems only)	-RJ4

Well Type	Part Number
2" Stainless Steel Well	ETI-WELL-2S
4" Stainless Steel Well	ETI-WELL-4S
6" Stainless Steel Well	ETI-WELL-6S

On October 1st, 2009, TAC became the Buildings business of its parent company Schneider Electric. This document reflects the visual identity of Schneider Electric, however there remains references to TAC as a corporate brand in the body copy. As each document is updated, the body copy will be changed to reflect appropriate corporate brand changes.

Copyright 2010, Schneider Electric
All brand names, trademarks and registered trademarks are the property of their respective owners. Information contained within this document is subject to change without notice.

Schneider Electric
1354 Clifford Avenue
P.O. Box 2940
Loves Park, IL 61132-2940

www.schneider-electric.com/buildings

