

AA09

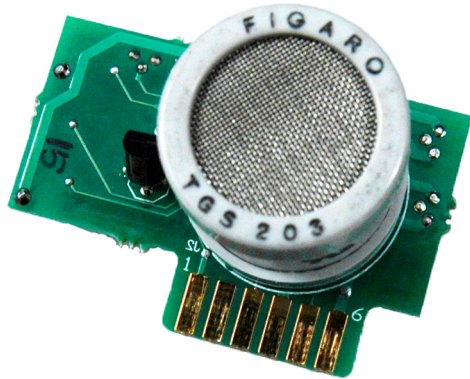

AA09

Replacement CO Sensing Module

INSTALLATION

1. Disconnect power from the unit.
2. Unscrew the transmitter cover.
3. Carefully remove the old sensor module. Module may be hot! If necessary, allow the unit to cool before proceeding.

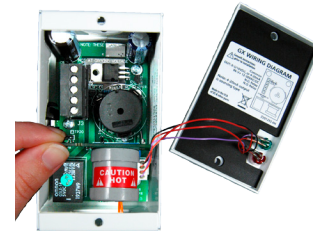

4. Plug the new module firmly into the socket.

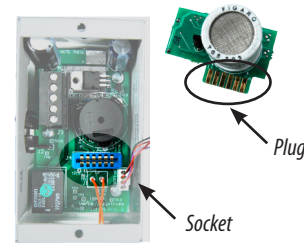

5. Replace cover, and reconnect power to the unit.

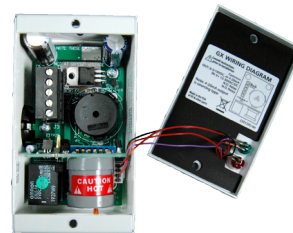

6. Allow 72 hours for the module to stabilize after initial power application.

NOTICE

- This product is not intended for life or safety applications.
- Do not install this product in hazardous or classified locations.
- Read and understand the instructions before installing this product.
- Turn off all power supplying equipment before working on it.
- The installer is responsible for conformance to all applicable codes.

PRODUCT IDENTIFICATION

AA09 Replacement CO Sensor

OPERATION

To assure continued reliable operation of the G Series CO transmitter, replace the AA09 sensor module every 5 years. The AA09 is factory calibrated. No field calibration is required or possible. Verify proper operation by observing LED indicators on the G Series device (see the G Series installation guide for details).

DIMENSIONS

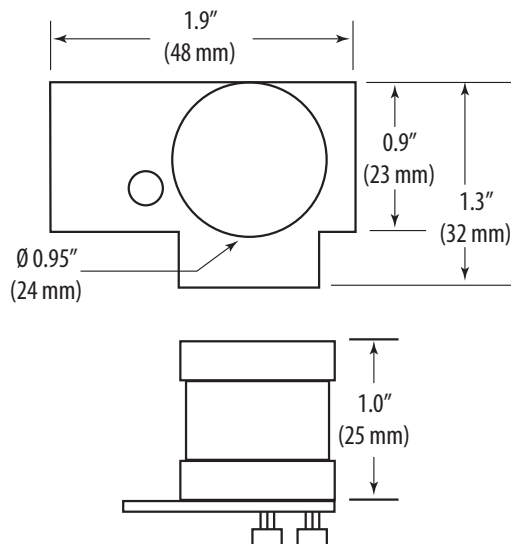

MechTronics
Controls
www.hvacusa.com
Phone (877) 632-4876