

Powermite 599 Series

MZ Series Zone Control Valve and Actuator Assembly Selection

Description

This Technical Bulletin will aid in selecting a Powermite 599 MZ Series zone control valve and actuator assembly. Begin with the graph of water capacity and the chart of close-off pressures to select a valve and actuator according to specifications. Use Table 1 to identify product numbers.

Table 1 shows all the possible combinations of the Powermite 599 Series valves and compatible actuators that can be ordered as complete valve assemblies from the factory.

The dimensions of all valves and the service envelope required for each actuator are included in Tables 2 through 4.

How To Use The Selection Graphs

Use Figure 1, the water capacity graph, to select a valve. Locate the specified flow rate on the vertical axis. Follow across on the horizontal line to the point of intersection with the specified pressure drop. Chose the valve size from the heavy diagonal lines across the graph.

Use Figure 2, the close-off pressure graphs, to select an actuator. First locate the graph for the valve action specified. Locate the bar that represents the valve line size. The top of the bar indicates the maximum close-off pressure for tight close-off.

How To Use The Valve Tables

Table 1 has been organized to help select a valve and actuator combination using additional specifications.

Moving from left to right, identify the valve assembly needed. Continue to the right to match the valve to a desired actuator.

A valve and actuator assembly part number is determined by combining the actuator prefix code with the suffix of the valve product number.

No valve will combine with all actuators. The symbol “—” indicates a combination that is a special order. A shaded space indicates an inappropriate combination.

Valve Tables

1/2- to 1-inch Valves

- Table 1 Two-way and Three-way Zone Valves

Page 4



hvacUSA.com
A MechTronics Controls Company

www.hvacusa.com
Phone (877) 632-4876

Selection Example

Select a two-way, normally closed, female by female NPT threaded valve and actuator assembly for an ANSI 250 piping system that will deliver 20 gpm (4.5 m³/h) chilled water with no more than 5 psi (35 kPa) pressure drop across the fully open valve.

Specification

The valve shall be operated by a 24 Vac powered, three-position control signal, fail-in-place electronic actuator, and must close off tightly against a pump head pressure of 15 psi (1 bar).

Valve Sizing

Use Figure 1, the water capacity graph, to begin valve sizing.

1. Locate 20 gpm (4.5 m³/h) on the vertical axis to find the required flow.
2. Read across the horizontal axis to find 5 psi (35 kPa), the maximum allowable pressure drop across the open valve.

Select a 1-inch (25 mm) 10 Cv (8.5 Kvs) line size valve because the point of intersection falls close to the 1-inch line.

Actuator selection

Use Figure 2, the close-off pressure graph for actuators on two way valves, to choose an actuator.

1. Locate the graph for the actuator on a two-way, NC valve in the upper left of the figure.
2. Locate the bar for 3/4 to 1-inch valves.

Notice that SSB... has the sufficient force to provide tight close-off against more than 15 psi (1 bar) differential.

Product Number Selection

Use Table 1.

Begin at the left and select the specifications necessary.

1. Select a two-way, normally closed, and FxF for female by female NPT threads, according to the specifications.
2. Select the 1-inch line size determined from the sizing example above.
3. The valve part number is 599-01114.
4. Read across the top of the table to Electronic-mechanical, 24 Vac, 3P control signal.
5. The actuator part number is SSB81U.
6. The actuator code number is 254.
7. Read down the column to determine the valve and actuator assembly product number is 254-01114.

NOTE: The valve and actuator can be ordered separately by using the part numbers from steps 2 and 3.

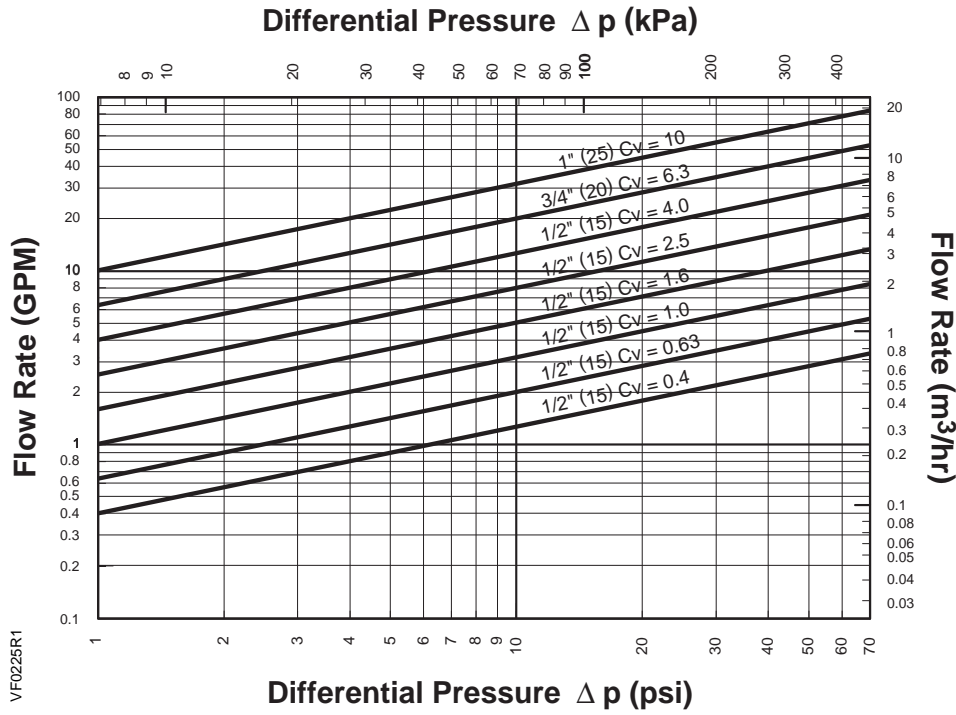

Figure 1. Water Capacity Graph.

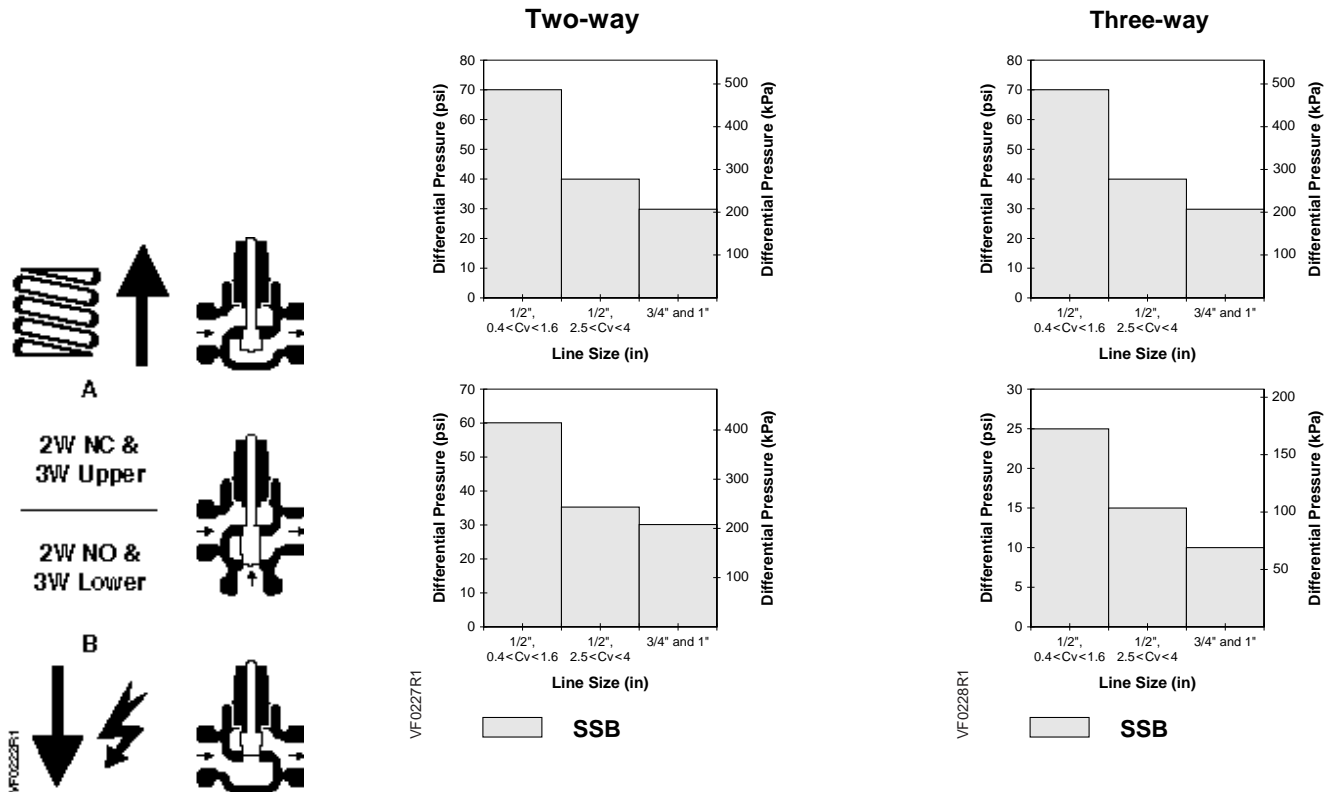

Figure 2. Maximum Available Close-off Pressures.

Table 1. MZ Series 1/2- to 1-inch Valves.

Port	Action	Connection	Flow Rate		Line Size		Type	Electro-Mechanical	
							Description	24V, 0 – 10V NSR	24V, 3P NSR
			Technical Instruction	155-192P25	155-195P25				
			Actuator Assembly	SSB61U	SSB81U				
Cv	Kvs	In	Mm	Valve Body Assembly	Actuator Code 255	Actuator Code 254			
2-Way Technical Instruction 155-198P25	Normally Closed	F x F	0.4	0.34	0.5	15	599-01100	255-01100	254-01100
			0.63	0.54	0.5	15	599-01102	255-01102	254-01102
			1.0	0.85	0.5	15	599-01104	255-01104	254-01104
			1.6	1.37	0.5	15	599-01106	255-01106	254-01106
			2.5	2.14	0.5	15	599-01108	255-01108	254-01108
			4.0	3.42	0.5	15	599-01110	255-01110	254-01110
			6.3	5.38	0.75	20	599-01112	255-01112	254-01112
		10	8.55	1.0	25	599-01114	255-01114	254-01114	
		F x UM	0.4	0.34	0.5	15	599-01101	255-01101	254-01101
			0.63	0.54	0.5	15	599-01103	255-01103	254-01103
			1.0	0.85	0.5	15	599-01105	255-01105	254-01105
			1.6	1.37	0.5	15	599-01107	255-01107	254-01107
			2.5	2.14	0.5	15	599-01109	255-01109	254-01109
			4.0	3.42	0.5	15	599-01111	255-01111	254-01111
	6.3		5.38	0.75	20	599-01113	255-01113	254-01113	
	Normally Open	F x F	0.4	0.34	0.5	15	599-01115	255-01115	254-01115
			0.63	0.54	0.5	15	599-01117	255-01117	254-01117
			1.0	0.85	0.5	15	599-01119	255-01119	254-01119
			1.6	1.37	0.5	15	599-01121	255-01121	254-01121
			2.5	2.14	0.5	15	599-01123	255-01123	254-01123
			4.0	3.24	0.5	15	599-01126	255-01126	254-01126
			6.3	5.38	0.75	20	599-01129	255-01129	254-01129
		10	8.55	1.0	25	599-01131	255-01131	254-01131	
		F x UM	0.4	0.34	0.5	15	599-01116	255-01116	254-01116
			0.63	0.54	0.5	15	599-01118	255-01118	254-01118
			1.0	0.85	0.5	15	599-01120	255-01120	254-01120
			1.6	1.37	0.5	15	599-01122	255-01122	254-01122
			2.5	2.14	0.5	15	599-01124	255-01124	254-01124
4.0			3.42	0.5	15	599-01127	255-01127	254-01127	
AF x UM	2.5	2.14	0.5	15	599-01125	255-01125	254-01125		
	4.0	3.42	0.5	15	599-01128	255-01128	254-01128		
3-Way Technical Instruction 55-199P25	Water Mix	F x F	0.4	0.34	0.5	15	599-01132	255-01132	254-01132
			0.63	0.54	0.5	15	599-01133	255-01133	254-01133
			1.0	0.85	0.5	15	599-01134	255-01134	254-01134
			1.6	1.37	0.5	15	599-01135	255-01135	254-01135
			2.5	2.14	0.5	15	599-01136	255-01136	254-01136
			4.0	3.42	0.5	15	599-01137	255-01137	254-01137
			6.3	5.38	0.75	20	599-01138	255-01138	254-01138
			10	8.55	1.0	25	599-01139	255-01139	254-01139

* AF = Angle Female NPT, F = Female NPT; UM = Union Male connection.

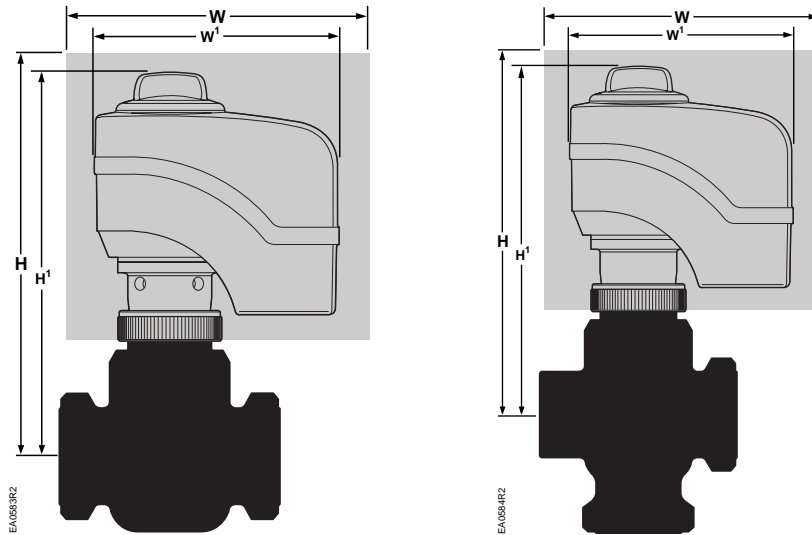

Figure 3.

Table 2. Dimensions of the Actuator and Recommended Service Envelope.
Dimensions in inches (millimeters)

Actuator	Actuator Prefix Code	Valve Line size	Center line to Top of Actuator H1	Service Height H	Width or Diameter of Actuator W1	Service Width W
SSB	254, 255	1/2 (15)	5-1/8 (130)	13-1/8 (330)	3-1/4 (83)	11-1/4 (282)
		3/4 (20)	5-1/8 (130)	13-1/8 (330)	3-1/4 (83)	11-1/4 (282)
		1 (25)	5-3/8 (136)	13-3/8 (335)	3-1/4 (83)	11-1/4 (282)

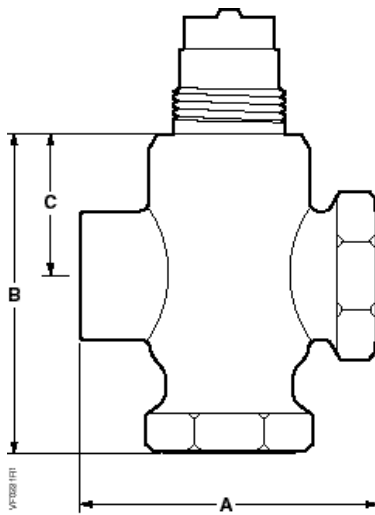
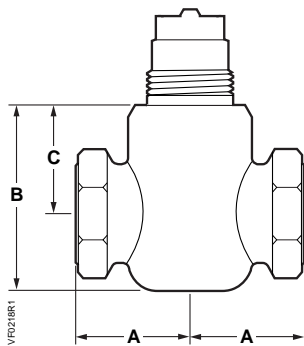

Table 3. Three-way Valve Dimensions.

Valve Size inch (mm)	A	B	C	Weight lb (kg)
1/2 (15)	2-3/4 (70)	2-15/16 (74)	1-5/16 (33)	1.10 (0.50)
3/4 (20)	3-1/4 (83)	3-9/16 (90)	1-5/16 (33)	1.44 (0.65)
1 (25)	3-7/8 (98)	3-15/16 (99)	1-9/16 (39)	2.20 (1.0)



Female NPT x Female NPT

FxF

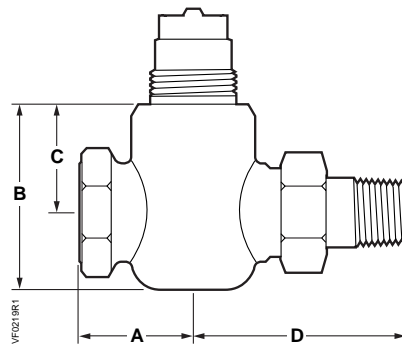

Female NPT x Union Male

FxUM

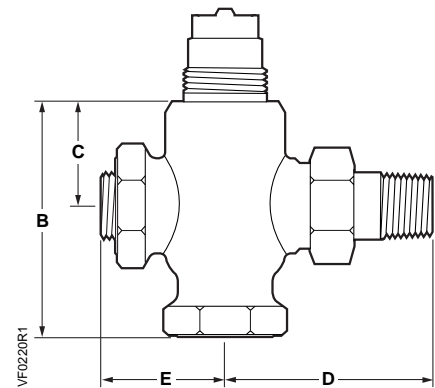

Angle Female x Union Male

AFxUM

Table 4. Two-way Valve Dimensions.

Valve Size inch (mm)	A	B		C	D	E	Weight lb-(kg)		
		FxF & FxUM	AFxUM				FxF	FxUM	AFxUM
1/2 (15)	1-3/8 (35)	2-1/4 (57)	2-15/16 (74) NO Only	1-5/16 (33)	2-5/8 (67)	1-1/2 (38) NO only	0.96 (0.44)	1.14 (0.5)	1.4 (0.6)
3/4 (20)	1-5/8 (41)	2-3/8 (59)	—	1-5/16 (33)	3-1/8 (79)	—	1.13 (.51)	1.45 (.66)	—
1 (25)	1-15/16 (49)	2-3/4 (69)	—	1-9/16 (39)	—	—	1.7 (.77)	—	—

Information in this publication is based on current specifications. The company reserves the right to make changes in specifications and models as design improvements are introduced. Product or company names mentioned herein may be the trademarks of their respective owners.
 © Siemens Industry, Inc.