

Powermite 599

MT Series SSC Electronic Valve Actuator, 24 Vac Floating Control

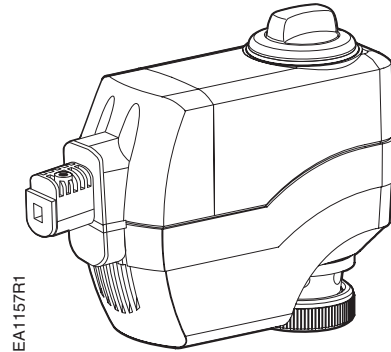

Description The Powermite 599 MT Series SSC81U and SSC81.5U electronic valve actuators require a 24 Vac supply to provide a floating control signal. These actuators control Powermite 599 MT Series valves with a 7/32-inch (5.5 mm) stroke and a threaded valve bonnet that fits the actuators.

-
- Features**
- UL listed for plenum installations
 - Direct-coupled installation without special tools (hand-tightened)
 - Manual override
 - Visual position indication

Application The Powermite 599 MT Series SSC81 electronic actuators and MT Series valves are used in heating and cooling applications. They are used in liquid and steam applications. The SSC81 series accepts plenum cable or 3/8-inch flex conduit connection.

Product Numbers

Table 1. Product Numbers.



Actuator	Operating Mode	Actuator Prefix Code
SSC81U	Non-Spring Return (Fail-in-Place)	259
SSC81.5U	Spring Return (Fail-Safe)	260

Ordering a Valve Plus Actuator Assembly

To order a complete valve plus actuator assembly from the factory, combine the actuator prefix code with the suffix of the valve product number. See *Technical Bulletin TB251, Powermite 599 Series MT Series Terminal Unit Valve and Actuator Assembly Selection* (155-306P25) for selection procedures.

To order an actuator only, use the product number.

Warning/Caution Notations

WARNING:		Personal injury or loss of life may occur if you do not perform a procedure as specified.
CAUTION:		Equipment damage may occur if you do not follow a procedure as specified.

Specifications

Power requirements	Operating voltage	24 Vac \pm 20%
	Frequency	50/60 Hz \pm 2 Hz
	Power supply	Earth ground isolating, Class 2, 24 Vac transformer
		NOTE: Do not power more than 10 actuators with one transformer.
	SSC81U power consumption	0.8 VA
	SSC81.5U power consumption	3 VA at ultra cap load, 2 VA at normal operation
Functional operation	Running time	
	SSC81U	125 s \pm 2% at 60 Hz
	SSC81.5U	125 s \pm 2% at 50/60 Hz
	Spring return, SSC81.5U only (Figure 1,)	\approx 30 s
	Nominal stroke	7/32-inch (5.5 mm)
	Nominal force	67 lb (300N)
	Stroke/signal relationship	Linear
	Capacitor charge time (Figure 1)	max. 180 sec
Spring return (SSC81.5U only)	Non-mechanical, electronic returns to stem up (0 position)	
Agency certification	UL	UL873 Listed
	cUL	Certified to CSA C22.2 No. 24-93
Ambient conditions	Ambient temperature	
	Operation	41°F to 122°F (5°C to 50°C)
	Transport and storage	-13°F to 158°F (-25°C to +70°C)
	Ambient humidity	0 to 90% rh (non-condensing)
	Media temperature	41°F to 248°F (5°C to 120°C)
Physical characteristics	Wiring Connection	Plenum cable or 3/8-inch flex conduit
	Weight	
	SSC81U	1.1 lb (0.5 kg)
	SSC81.5U	1.3 lb (0.6 kg)
	Dimensions	See Figure 10

Service Kits

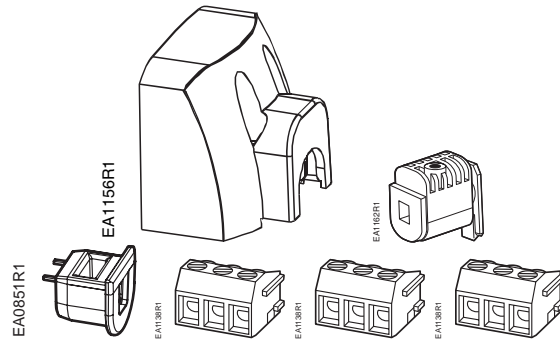

41155648 For actuators with date codes of 031215F or later.
 Kit contains:
 - Terminal cover
 - Cover screws-2 (not shown)
 - Tailpiece
 - Tailpiece screw-1 (not shown)
 - Cable lock
 - Terminal block-3

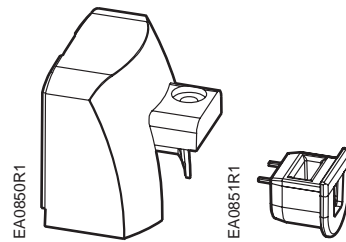

411656088 For actuators with date codes before 031215F.
 Kit contains:
 - Terminal Cover
 - Cable lock
 - Cover screw- 1 (not shown)

Operation

A 24 Vac control signal to terminal Y1 extends the actuator shaft proportionately to the length of time the signal is applied.

A 24 Vac control signal to terminal Y2 retracts the actuator shaft proportionately to the length of time the signal is applied.

In the event of a power failure with no control voltage, the non-spring return SSC81U will hold its last position.

In the event of a power failure, the SSC81.5U returns to the stem up 0 position. The SSC81.5U includes an electronic return mechanism that functions as follows. See Figure 1.

- At power-up (t_0), a capacitor must charge to its maximum capacity (Max, t_c). This will take a maximum of 180 sec, during which time no actuator movement occurs.
- Once the capacitor is fully charged (t_c), normal actuator operation occurs.
- If a subsequent power failure occurs (t_n) of greater than 5 seconds, the capacitor discharges (t_d) and the actuator spring returns to stem up 0 position.

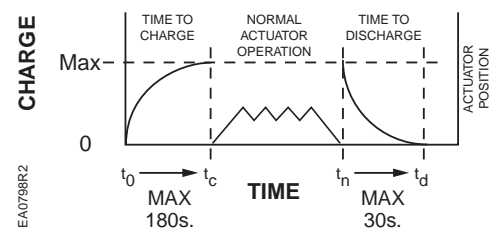

Figure 1. SSC81.5U Electronic Spring Return Mechanism.

Operation, Continued



CAUTION:

A valve must be connected to the actuator before applying power.

If applying power to the actuator when a valve is not connected, the actuator will respond to a control signal and the shaft will extend until it reaches its maximum end stop. Thereafter, it will not respond to any signal. If this occurs:

1. Disconnect power.
2. Turn the manual position indicator (See Figure 8 and Figure 9) on the top of the actuator to the 0 position and verify the actuator shaft completely retracts.
3. Connect a valve to the actuator, reapply power. The actuator will return to normal operation.

Calibration Stroke

The SSC81.5U writes its calibration stroke parameters to nonvolatile memory on the first startup of the actuator. Successive startups bypass the calibration stroke unless the memory is manually cleared. If installing the actuator on a different valve (such as on a replacement valve), manually clear the calibration stroke from memory as follows:

1. Remove the terminal cover using a Phillips head screwdriver.
2. Locate hole on the circuit board shorting bars.
3. Insert and gently twist a flat-blade screwdriver to electrically connect the shorting bars (Figure 2). The SSC81... then performs a new calibration stroke.
4. Secure the terminal cover back in place.

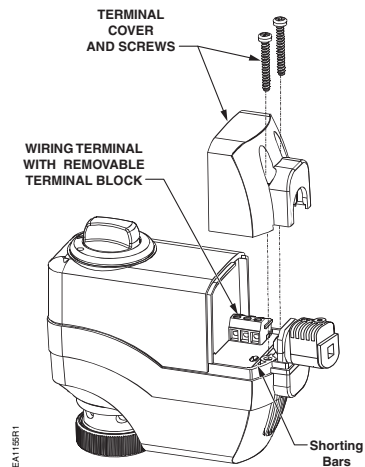

Figure 2. Manually Clearing Calibration Stroke from Memory.

Mounting and Installation

Mount the actuator in one of the allowable positions shown in Figure 3.

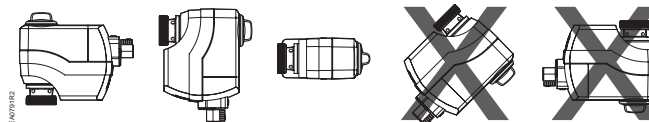

Figure 3. Mounting Position.

When mounting the actuator in a plenum, the proper cable must be attached to meet local codes. Allow 8 inches (200 mm) above the actuator and 8 inches (200 mm) behind the cable for service.

Wiring

Use earth ground isolating, step-down Class 2 transformers. Do not use autotransformers.

Determine supply transformer rating by summing total VA of all actuators used. The maximum rating for a Class 2 step-down transformer is 100 VA.

Do not power more than 10 actuators by one transformer. (Use 0.5 amp fuse on secondary actuator.)

NOTE: Can be wired either neutral or hot switched.



CAUTION:

Terminals must be properly wired for correct function and full life of the actuator.

Wiring Diagrams

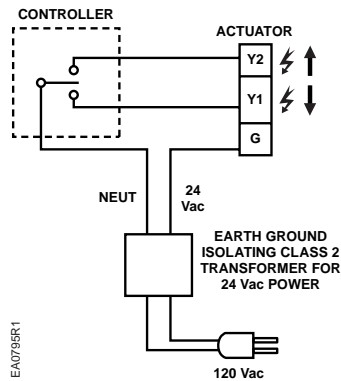

Figure 4. SSC81U Neutral Switching Non-Spring Return.

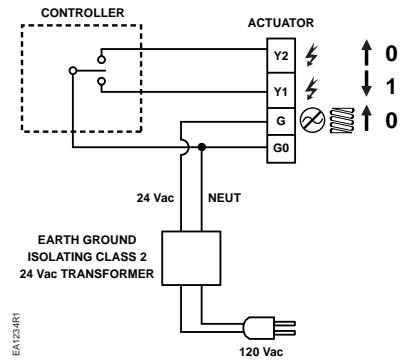

Figure 5. SSC81.5U Neutral Switching Spring Return.

- Y2 Retracts actuator shaft
- Y1 Extends actuator shaft
- G System potential (hot)
- G0 Neutral – (SSC81.5U Only)

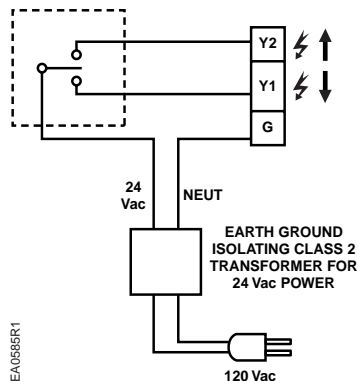

Figure 6. SSC81U Hot Switching Non-Spring Return.

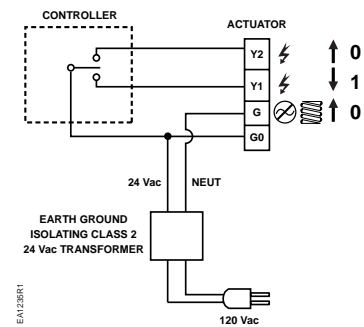

Figure 7. SSC81.5U Hot Switching Spring Return.

- Y2 Retracts actuator shaft
- Y1 Extends actuator shaft
- G Neutral
- G0 System potential (hot) -SSC81.5U Only

Manual Override

For manual positioning, the override knob is in the center of the position indicator. See Figure 8.

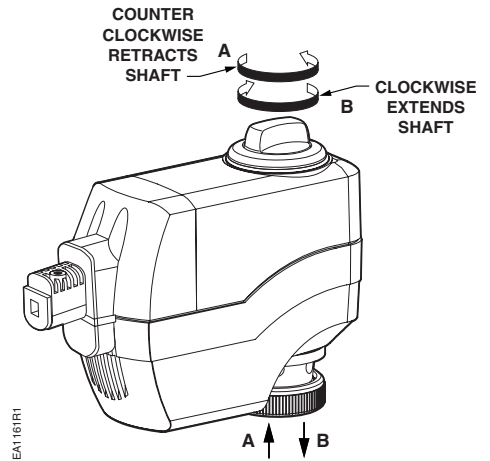

Figure 8. Manual Override.

Start-up

Check the wiring and the position indicator (Figure 9).

Position Indicator	Output Shaft
0	Retracted
1	Extended

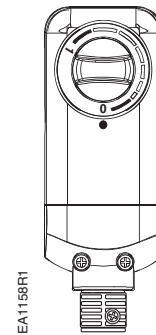

Figure 9. Position Indicator (Shown in 0 Position).

Troubleshooting

Check the wiring for proper connections.

Service Kits

If the actuator is inoperative, replace the unit.

Dimensions

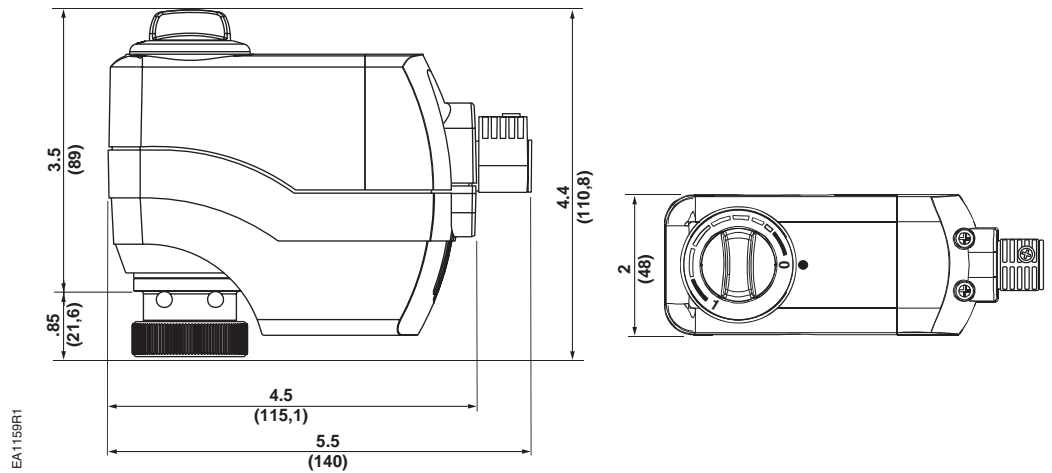

Figure 10. SSC Actuator Dimensions in Inches (Millimeters).

Service envelope

Minimum access space recommended:

8 inches (200 mm) above the actuator and 8 inches (200 mm) beside the terminal cover.

Information in this publication is based on current specifications. The company reserves the right to make changes in specifications and models as design improvements are introduced. Product or company names mentioned herein may be the trademarks of their respective owners.
© 2011 Siemens Industry, Inc.