

Powers™ Controls

Bulb Installation: Low Temperature Detection Thermostats

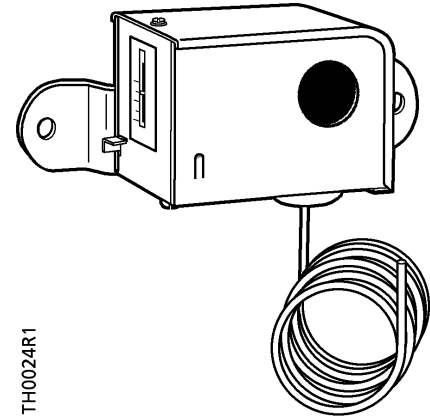

Description

This Technical Bulletin covers proper bulb installation instructions for Powers Controls Electric Low Temperature Detection Thermostats.

This thermostat has a limited vapor charge since its liquid volume is less than the volume of 12 inches (305 mm) length of the bulb. When at least 12 inches (305mm) of the bulb is exposed to a temperature of at least 1°F (0.6°C) below the thermostat set point, the charge begins to accumulate and condense in this section. The condensing charge creates a vacuum into which the remaining charge is drawn and also condensed. When both liquid-vapor surfaces are within a 12-inch (305 mm) length, the vapor pressure in the thermal system and the bellows decrease until the electrical contacts open. See *Figure 1*.

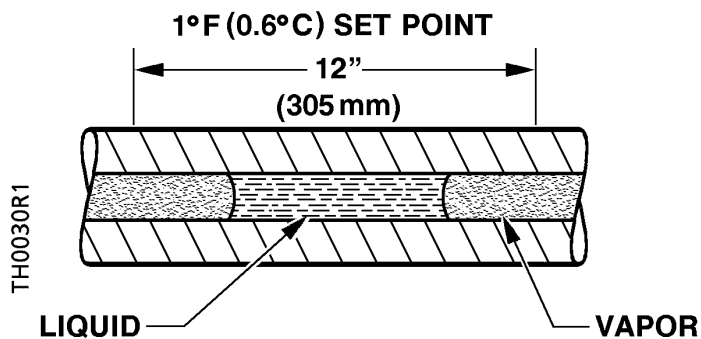



Figure 1. Horizontal Cross Section.

For proper operation, the thermostat case and bellows ambient temperature must be warmer than the bulb temperature. If the thermostat bellows is colder than the bulb, the charge accumulates in the bellows, and the case temperature controls the action of the thermostat rather than the bulb temperature.

Caution/Warning Notations

WARNING:		Personal injury/loss of life may occur if a procedure is not performed as specified.
CAUTION:		Equipment damage may occur if the user does not follow a procedure as specified.

Features

- Low temperature detection in less than two minutes
- Detection of 1°F (0.6°C) temperature drop below set point
- 20-foot (6m) long bulb
- Temperature detection in any 12-inch continuous length of bulb

Application

The Low Temperature Detection Thermostat should be used wherever there is a coil that may be exposed to cold temperatures which may cause the coil to freeze.

Installation

General Guidelines



CAUTION:

Do not install the bulb in extended vertical rows, the condensing charge will not accumulate properly. Only the part of the bulb in horizontal rows will effectively detect cold spots.

- Locate the sensing elements in the downstream side of the coil.
- Locate the case and bellows where the ambient temperature is always warmer than the set point.
- Install the thermostat case so that the reset button is readily accessible and the element bellows point down.
- Avoid sharp bends or kinks in the sensing element.
- Install as much of the bulb as possible in horizontal rows. If too much of the bulb is installed vertically, it will not operate properly.

Large Walk-in Ducts (Figure 2)

Attach the mounting bracket to the thermostat case with the two round head screws provided.

Mount the two perforated steel strap hangers inside the duct with the wide part of the hanger strap parallel to the air flow.

Drill a hole through the side of the duct. With the bulb still coiled, thread the bulb through the hole using a rotary movement.

Mount the thermostat case to the outside of the duct in a location that is warmer than the bulb.

Carefully uncoil the bulb avoiding sharp bends or kinks in the sensing element.

Mount the bulb in a horizontal, serpentine manner. Attach the bulb to the strap as shown in detail in Figure 2. To avoid crimping the bulb, the bends should not have radii less than 1-1/2 inches.



CAUTION:

Do not bend the bulb too tightly on the corners. This causes poor flow and limits the effectiveness of the bulb.

**Installation,
Continued**

NOTE: The bulb should be mounted at a distance not greater than six inches from the edge of the coil.

- On coils that have multiple bypass channels within the coil frame, insulate the bulb where it may be exposed to bypass air.

The installation is now complete.

NOTE: For an alternate method of mounting, use coil clips (Part Number 356-115) to hold the bulb in a horizontal, serpentine pattern.

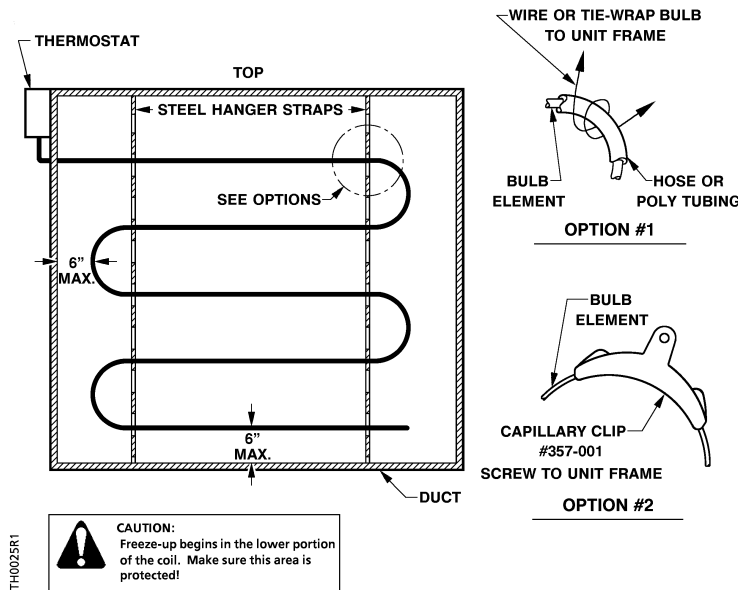

Figure 2. Mounting for Large Walk-in Ducts.

NOTE: Use of the poly tubing or capillary clip as shown in options 1 and 2 of *Figure 2* is important to protect the element from metal to metal contact. Use a rubber grommet or poly tubing to protect the bulb at its point of entry into the air handler.

**Limited Access Ducts
(Figure 3)**

- Attach the mounting bracket to the thermostat case with the two round head screws provided.
- Attach a mounting flange (Part Number 808-412, *Figure 4*) on the opposite side of the duct (near the bottom) from where the thermostat will be mounted.
- Mount a second flange on an 8-inch by 4-inch sheet metal plate. Cut an access opening for the bulb on the duct diagonally across from the duct mounted flange. Drill mounting screw holes for the sheet metal plate.
- Cut a length of copper tubing to fit diagonally across the duct. Stretch the bulb and wrap it around the copper tubing.

NOTE: The bulb should be fastened securely to the copper tubing with insulated wire ties to prevent vibration and metal to metal contact.

**Limited Access Ducts,
 Continued**

5. Insert the tubing and bulb through the access hole and into the duct-mounted flange. Fasten the 8-inch by 4-inch sheet metal plate to the duct.
6. Mount the thermostat case to the outside of the duct in a location that is warmer than the bulb.

The installation is now complete.

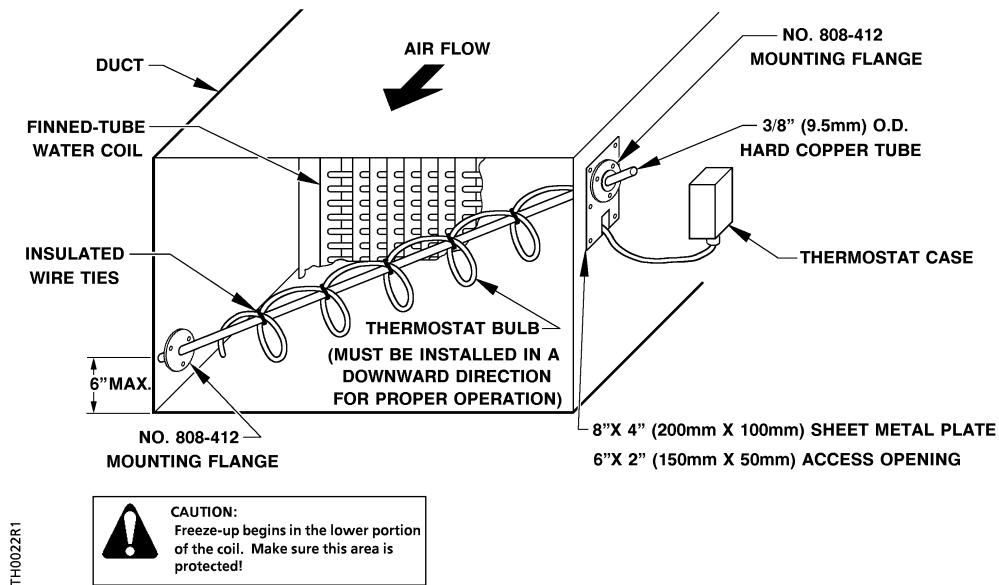

Figure 3. Mounting for Limited Access Ducts with Mounting Flange.

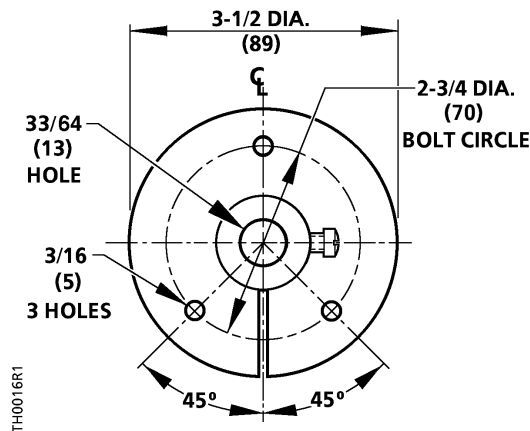

Figure 4. Mounting Flange (Part Number 808-412).

Information in this publication is based on current specifications. The company reserves the right to make changes in specifications and models as design improvements are introduced. Powers is a registered trademark of Siemens Industry, Inc. Product or company names mentioned herein may be the trademarks of their respective owners. © 2005 Siemens Industry, Inc.