

Flowrite™ AP 599 Series

12-inch Pneumatic Valve Actuator

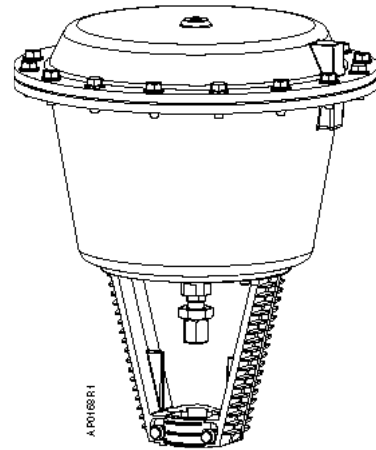

Description

The Flowrite™ AP 599 Series 12-inch pneumatic valve actuator is designed for use with the Flowrite VF 599 Series valves. This actuator is available with two stem strokes.

Features



- Completely enclosed actuator housing protects the diaphragm, springs, and start point adjuster.
- Positioning relay is available factory-mounted or as an accessory.
- Start point of the actuator spring is adjustable. This allows the valve to be sequenced.
- Easy installation.

Product Numbers

Table 1.

Product Number	Actuator	Type	Actuator Code
599-01010	3/4" (20 mm) stroke	Pneumatic	279
		Pneumatic with Factory Mounted Positioning Relay	285
599-01000	1-1/2" (40 mm) stroke	Pneumatic	281
		Pneumatic with Factory Mounted Positioning Relay	287

Warning/Caution Notations

WARNING		Personal injury/loss of life may occur if you not perform a procedure as specified.
CAUTION		Equipment damage, or loss of data may occur if you do not perform a procedure as specified.

Specifications	Effective diaphragm area	90 inch ² (580 cm ²)
	Diaphragm material	Buna-N
	Nominal spring range	
	Fixed span	5 psi (34 kPa)
	Adjustable start point	3 to 10 psi (21 to 69 kPa)
	Factory setting	3 to 8 psig (21 to 55 kPa) NO valves 10 to 15 psig (69 to 103 kPa) NC valves
	Nominal stroke	3/4 inch (20 mm) 1-1/2 inch (40 mm)
	Maximum diaphragm pressure	35 psi (241 kPa)
	Air Connection	1/4-inch NPT
	Medium temperature	25 to 366°F (-4 to 186°C)
	Ambient operating and storage temperature	35 to 180°F (2 to 85°C)
	Mounting location	NEMA 1 (interior only)
	Dimensions	17-7/8" H x 15-1/8" dia. (454 mm H x 384 mm dia.)
Shipping weight	53 lb (24 kg)	
Application	These 12-inch actuators are designed to be used on Flowrite VF 599 Series valves in liquid service and steam service.	
Operation	The control air signal upon the diaphragm causes the valve to modulate whenever the air pressure is within the spring range of the actuator. The actuator springs provide the necessary force to hold the stem in the stem up (direct acting) position.	
Accessories	Packing Heater Kit	599-00418
	Positioning Relay and Mounting Kit	599-00423
	Instructions for mounting are included with the accessory.	
	Spring Clamp (secures 1/4-inch O.D. poly tubing to barb-fitting at higher control pressures or elevated temperatures)	531-833
Service Kits	Retainer Bracket Kit	599-00436
	Diaphragm Replacement Kit	599-01070
	Stem retainer kit	
	2-1/2 inch and 3-inch valves	599-10048
4-inch, 5-inch, and 6-inch valves	599-10049	

Mounting and Installation

Allow 12 inches (300 mm) above and 6 inches (150 mm) on each side of the actuator for servicing.

For best performance, install the actuator vertically above the valve. The actuator may be installed in any position between vertical and horizontal. Siemens Building Technologies does not recommend installing the actuator below horizontal or upside down. See Figure 1 for acceptable mounting positions.

Complete instructions for field mounting the actuator are included with the actuator.

The top edge of the stem nut indicates the valve stem position. The “0” marking on the actuator yoke indicates stem up position. The “1” mark indicates stem down position. See Figure 3.

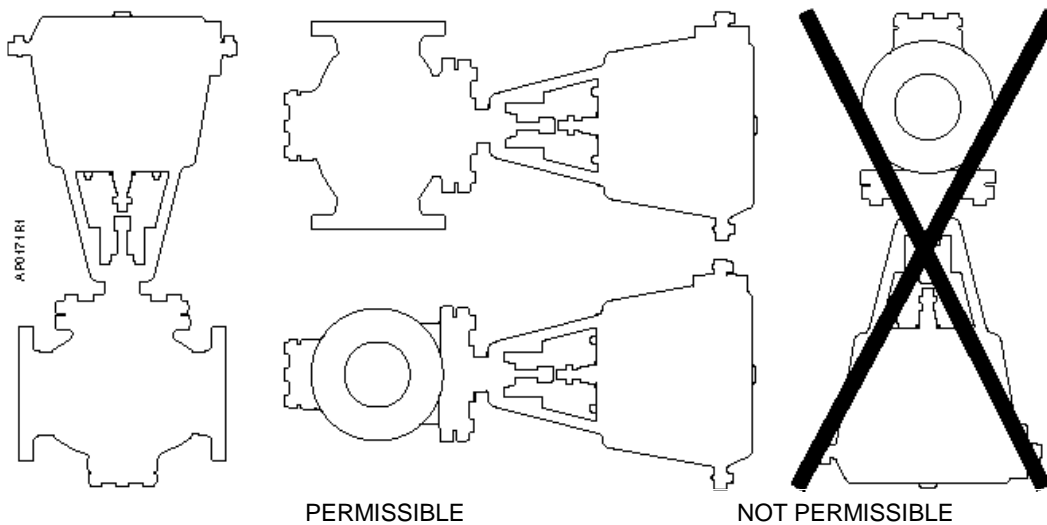

Figure 1. Mounting Positions.

Table 2. Parts List. See Figure 2.

Item	Description	Q'ty	Material
1	3/8-16 thread forming screw	16	Plated Steel
2	Upper housing	1	Aluminum
3	Diaphragm	1	Buna-N
4	Piston plate	1	Aluminum
5	Spring	6	Chrome Silicon Steel
6	Anti-spin rod	2	Plated Steel
7	Adjuster retaining ring	1	
8	M20 x 1.5 flat hex jam nut	1	Plated Steel
9	1/4-20 external tooth lock washer	2	Plated Steel
10	1/4-20 x 2-1/4 hex head cap screw	2	Plated Steel
11	Actuator shaft	1	
	3/4" (20 mm) stroke		Yellow Chromate Plated Steel
	1-1/2" (40 mm) stroke		Bright Chromate Plated Steel
12	Start point adjuster	1	Brass
13	Spring plate	1	Aluminum
14	Lower housing	1	Aluminum
15	Stem retainer clip	1	Stainless Steel
16	Stem nut	1	Stainless Steel
17	Actuator retainer	1	Aluminum
18	Washer	6	—
19	#8 Thread forming screw	6	—
Retainer bracket kit — Items 9, 10 and 17			599-00436
Diaphragm replacement kit — Items 3, 18, and 19			599-01070
Stem retainer kit — Items 15 and 16			
For 2-1/2 and 3 inch valves			599-10048
For 4, 5, and 6-inch valves			599-10049

Service

Diaphragm Replacement

Complete instructions are included in the diaphragm replacement kit.



WARNING:

Relieve spring tension before removing the actuator upper housing.

Parts of the Actuator

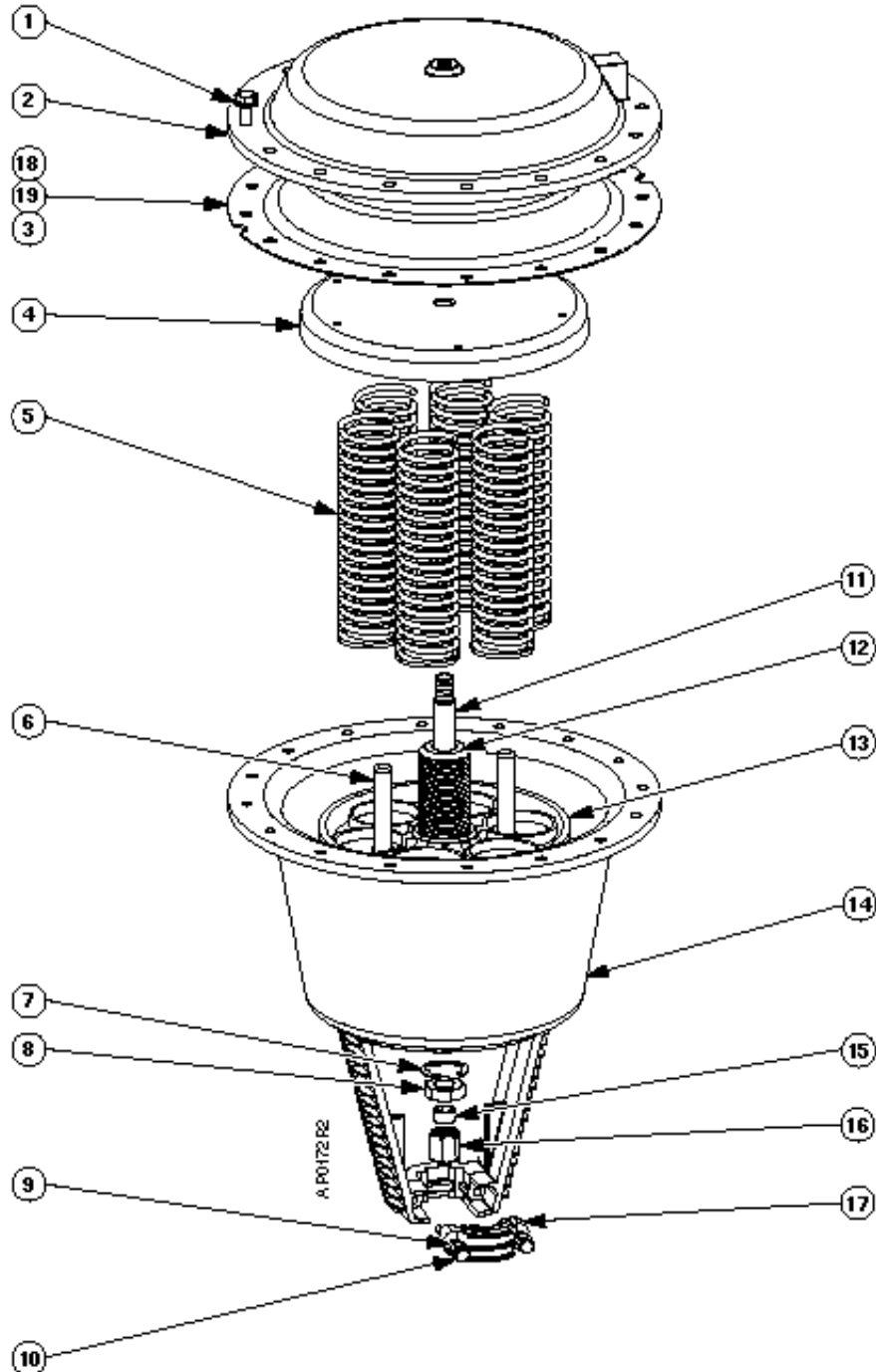

Figure 2. Flowrite AP 599 Series 12-inch Pneumatic Valve Actuator. See Table 2.

Spring Adjustment

With the actuator in an upright position and the stem visible as shown in Figure 3, use a 1-1/16 inch open-end wrench to turn the adjustment screw.

- Normally Open Valves: To increase the start to close pressure, turn the adjustment screw from right to left. To decrease, turn the adjustment screw from left to right.
- Normally Closed Valves: To increase the start to open pressure, turn the adjustment screw from right to left. To decrease, turn the adjustment screw from left to right.

NOTE: As the line pressure differential across the valve increases, the spring span will increase.

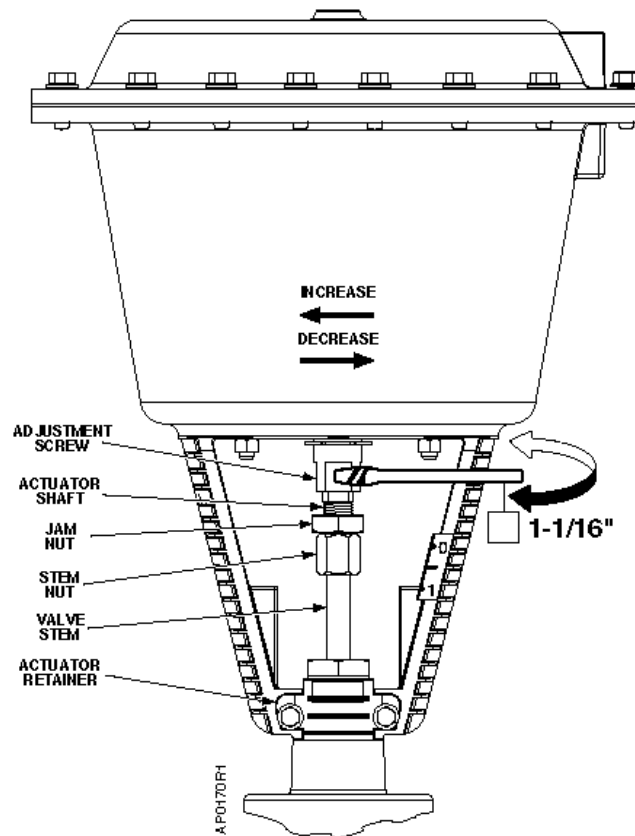

Figure 3. Spring Adjustment.

Information in this publication is based on current specifications. The company reserves the right to make changes in specifications and models as design improvements are introduced. Flowrite is a registered trademark of Siemens Industry, Inc. Product or company names mentioned herein may be the trademarks of their respective owners. © 2009 Siemens Industry, Inc.