

Powers™ Controls

Low Temperature Detection Thermostat

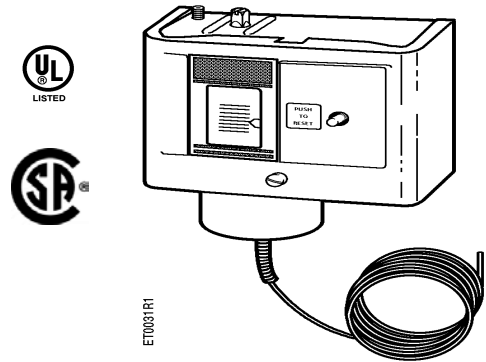

Description

The electric Low Temperature Detection Cut-out and Alarm Thermostat is a remote bulb instrument which opens an electrical circuit to stop the supply fan motor and/or closes an outside air damper when the temperature at the sensing element falls below the setting of the instrument. Simultaneously, it closes a circuit to indicate an alarm condition.



Features

- Manual reset
- Easy temperature setting with adjusting screw on top of enclosure
- Mounting bracket and two screws included
- Main and separate reverse-acting auxiliary contacts

Product Number

134-1504

Warning/Caution Notations

WARNING		Personal injury, or loss of life may occur if a procedure is not performed as specified.
CAUTION		Equipment damage, or loss of data may occur if you do not follow a procedure as specified.

Application

This instrument should only be used on those applications where the ambient temperature to which the instrument case and bellows are exposed remains above the temperature setting of the thermostat. This thermostat should be used in areas protected from the weather.



WARNING:

This low temperature detection thermostat is designed for use only as an operating control. Where an operating control failure would result in personal injury and/or loss of property, it is the installer's responsibility to add devices (safety, limit controls) or systems (alarm, supervisory systems) that protect against, or warn of control failure.

Specifications

Switch Action	Main (LINE-M2) contacts open on temperature drop, simultaneously auxiliary contacts close
Range	15 to 55°F (-9 to 13°C)
Maximum bulb temperature	400°F (204°C)
Minimum differential	5°F (2.8°C) Non-adjustable
Sensing element	Vapor filled
Bulb length	1/8-inch OD x 20 feet (6 m)
Reset action	Manual
Electrical rating	See Table 1
Weight	2.4 lb (1.1 kg)
Dimensions	See Figures 2 and 5
Approvals	UL file SA 10816 CSA file LR948

Operation

This thermostat incorporates a temperature sensing element of the vapor-filled type which actuates a heavy duty contact through a rugged link mechanism.

Any one-foot length of the element subjected to temperatures below the temperature setting of the thermostat will actuate the thermostat switch mechanism regardless of the temperature being sensed by the remainder of the element. This makes the thermostats ideal for protecting large coils where air stratification could cause freezing conditions in a localized area.

The thermostat has a main and auxiliary contact unit. The main load circuit (LINE-M2) opens on temperature drop and simultaneously, an auxiliary or alarm circuit (LINE-MI) closes on temperature drop.

NOTE: The reset button must be manually pressed down and released to resume normal fan system operation.

Electrical Ratings

Table 1.

Pole Number	Line-M2 (Main)				Line-M1 (Auxiliary)			
	120V	208V	240V	277V	120V	208V	240V	277 V
AC Full Load Amps	16.0	9.2	8.0	—	6.0	3.3	3.0	—
AC Locked Rotor Amps	96.0	55.2	48.0	—	36.0	19.8	18.0	—
AC Non-Ind Amps	16.0	9.2	8.0	7.2	6.0	6.0	6.0	6.0
Pilot Duty-Both Poles		125 VA, 24 to 600 Vac 57.5 VA, 120 to 300 Vdc						

Mounting and Installation

General Guidelines

- Locate the sensing element in the downstream side of the coil.
- Locate the case and bellows where the ambient temperature is always warmer than the setpoint.
- Install the thermostat so that the reset button is readily accessible and the element bellows points down.
- Install as much of the bulb as possible in a horizontal plane. If too much of the bulb is vertical, it will not operate properly.
- Avoid sharp bends or kinks in the sensing element.

Large walk-in Ducts (Figure 1)

1. Attach the mounting bracket to the thermostat with the two round head screws provided.
2. Mount the two perforated steel strap hangers inside the duct with the wide part of the hanger strap parallel to the air flow.
3. Drill a hole in the side of the duct. With the bulb still coiled, thread the bulb through the hole using a rotary movement.
4. Mount the thermostat on the outside of the duct.
5. Carefully uncoil the bulb avoiding sharp bends or kinks in the sensing element.
6. Mount the bulb in a horizontal, serpentine manner, attaching the bulb to the strap as shown in detail in Figure 1.

The installation is complete.

NOTE: For an alternate method of mounting, use coil clips (Part Number 356-115) in the fins to hold the bulb in a horizontal, serpentine pattern.

Mounting and Installation, Continued

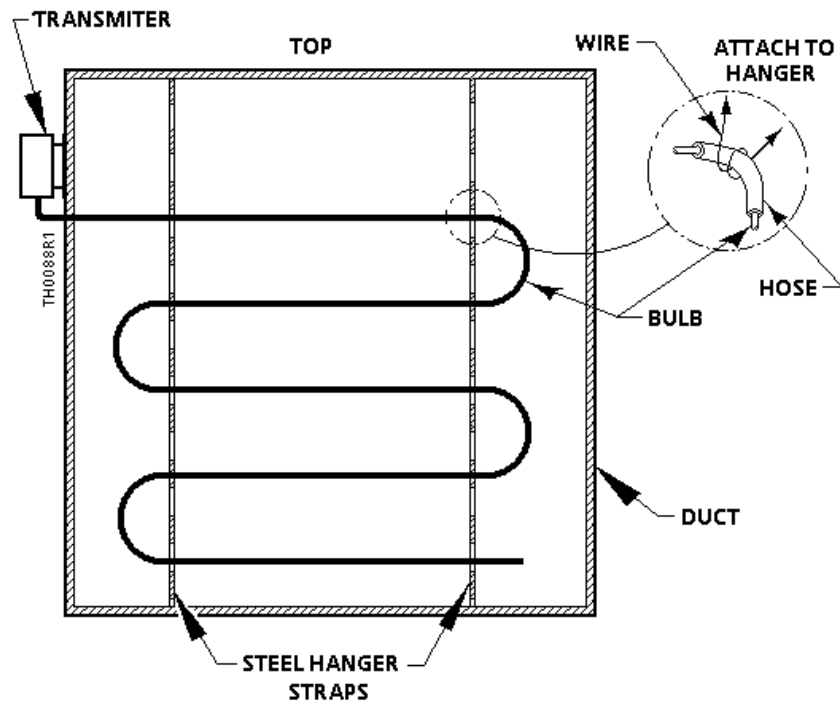

Figure 1. Typical Mounting in Walk-in Duct.

Limited Access Ducts (Figure 2)

1. Attach the mounting bracket to the thermostat with the two round head screws provided.
2. Attach a mounting flange (Part Number 808-412) on the opposite side of the duct (near the bottom) from where the thermostat will be mounted.
3. Mount a second flange on an 8-inch by 4-inch sheet metal plate. Cut an access opening for the bulb on the duct diagonally across from the duct-mounted flange. Drill mounting screw holes for the sheet metal plate.
4. Cut a length of copper tubing to fit diagonally across the duct. Stretch out the bulb and wrap it around the tubing. See Figure 2.
5. Insert the tubing and bulb through the access hole and into the duct-mounted flange. Fasten the 8-inch by 4-inch sheet metal plate to the duct.
6. Mount the thermostat on the outside of duct.

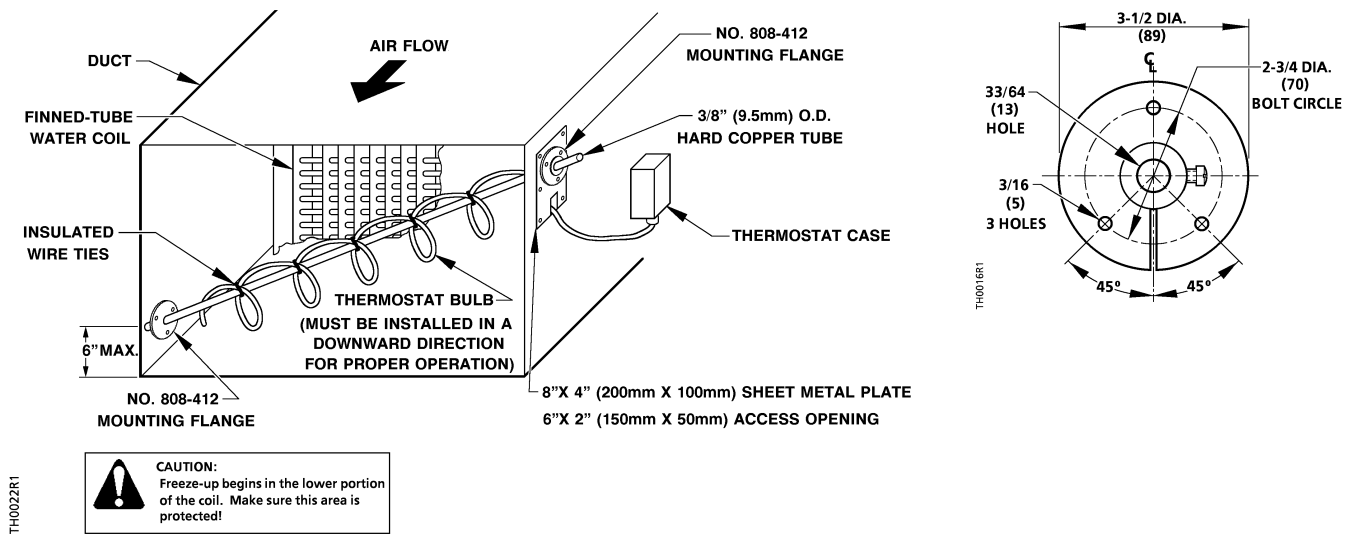

Figure 2. Bulb Mounting for Limited Access Ducts with 808-412 Mounting Flange.

Wiring



WARNING:

Disconnect the power supply before wiring connections are made to avoid possible electrical shock or damage to the equipment.

Make all wiring connections using copper conductors only and in accordance with the National Electrical Code and local regulations. Loads exceeding the rating of the thermostat should be handled by means of a relay or motor starter.

An opening for 1/2-inch conduit is provided in the bottom of the thermostat enclosure.

See Figure 3 for a typical wiring diagram.

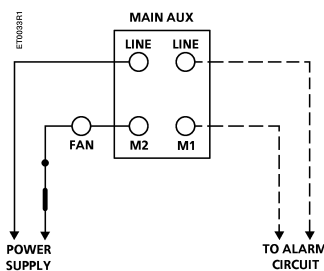

Figure 3. Typical Wiring Diagram.



CAUTION:

Use terminal screws furnished (#8-32 x 1/4-inch binder head screw). Longer terminal screws can interfere with switch mechanism and damage the switch.

Adjustment

After mounting the thermostat, adjust the temperature setting using the setpoint adjusting screw on the top of the enclosure. See Figure 4.

Observe a complete operating cycle to be sure that all components function correctly.

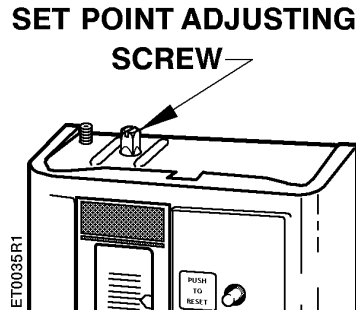

Figure 4. Setpoint Adjustment Screw.

Calibration

There is no field calibration required for the thermostat.

Troubleshooting

Observe a complete operating cycle to be sure that all components function correctly.

Service

There is no servicing of the thermostat. Replace if inoperative.

Dimensions

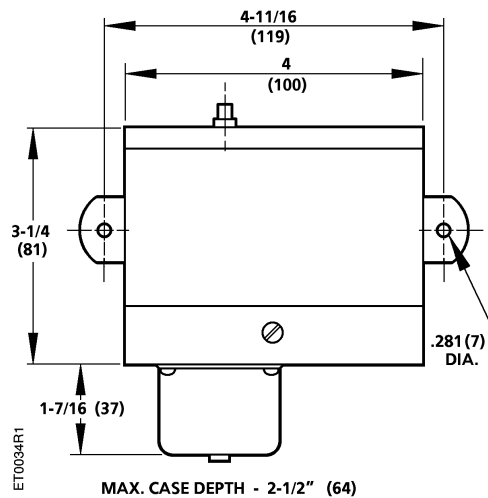

Figure 5. Dimensions in Inches (Millimeters).

Information in this publication is based on current specifications. The company reserves the right to make changes in specifications and models as design improvements are introduced. Powers is a registered trademark of Siemens Industry, Inc. Product or company names mentioned herein may be the trademarks of their respective owners. © 2005 Siemens Industry, Inc.