

Duct Averaging Sensors Long Bendable Probe, 4 to 20 mA

Product Description

The temperature transmitter equipped Duct Averaging Sensor assembly senses the average air temperature in ductwork where mixing baffles are not provided or where stratification occurs. Each sensor assembly mounts on sheet metal ducts.

Contents

- Long, bendable, platinum RTD averaging element
- 4 to 20 mA transmitter
- Electrical box for wiring connections

Product Numbers

Product Number	Sensing Element	Range
533-380-XX	100 Ω Pt (385α)	20°F to 120°F (-7°C to 49°C)
XX	Insertion Length in Feet (m)	
8	8 (2)	
16	16 (5)	
24	24 (7)	

Warning/Caution Notations

CAUTION:		Equipment damage may occur if you do not follow a procedure as specified.
-----------------	---	---

Required Tools

- Wire cutters
- Small, 1/8-inch wide flat-blade screwdriver
- Medium flat-blade screwdriver
- Four No. 10 × 1-inch sheet metal screws
- Electric drill
- 1/2-inch (13 mm) and 7/8-inch (22 mm) drill bits
- No. 27 drill bit for screw holes
- Tin snips
- Wire ties suitable for service in the ductwork

Expected Installation Time

2.4 hours

Recommended Bulb Configuration

Figures 1 and 2 show the sensing element arrangements. They provide the fastest response when the element is exposed to cold temperatures. Figure 1 shows the most practical mounting arrangement; it does not require inside access to the duct. The other sensing element arrangements require inside access to the duct.

Mounting Hardware

Required for limited access duct mounting option (Figure 1):

- Two mounting flanges (P/N 808-412).
- 16 No. 10 × 1-inch sheet metal screws.
- Tin snips.
- Pre-cut and drilled 8 × 4-inch (200 × 100 mm) piece of sheet metal.
- Support rod of 3/8-inch OD copper or suitable equivalent, long enough to fit diagonally across the duct.

Required for walk-in duct mounting option (Figure 2):

- Perforated steel hanger strap long enough to traverse the duct at least twice.
- Wire ties suitable for service in the ductwork.
- Four No. 10 × 1-inch sheet metal screws.

Prerequisites

- The signal wiring must be pulled to the installation site and enclosed in 3/8-inch (9.5 mm) flexible conduit.
- For the limited access duct option, mount one P/N 808-412 mounting flange and the sensor on the 8 × 4-inch sheet metal plate.

Instructions for Limited Access Duct Mounting Option



CAUTION:

The duct sensing element is used to detect temperature stratification in the duct. For proper operation, be sure to mount the sensing element at an angle, as shown in Figure 1.

When uncoiling the sensing element, do NOT severely bend or kink the element. The diameter of any bend should be no less than six inches (152 mm).

1. Position one P/N 808-412 mounting flange on the opposite side of the duct (near the bottom) from where the 8 x 4-inch (200 mm x 100 mm) mounting plate is to be mounted. See Figure 1. Mark the four screw holes and the 1/2-inch (13 mm) center hole of the mounting flange.
2. Drill the screw holes with the No. 27 drill bit.
3. Drill the center hole using a 1/2-inch (13 mm) drill bit.
4. Mount the mounting flange on the duct.
5. Cut a vertical access hole 6 inches high x 2 inches wide (150 x 50 mm) (near the top of the duct) on the side opposite of the previously mounted mounting flange. See Figure 1. Mark and drill mounting screw holes for the sheet metal plate.

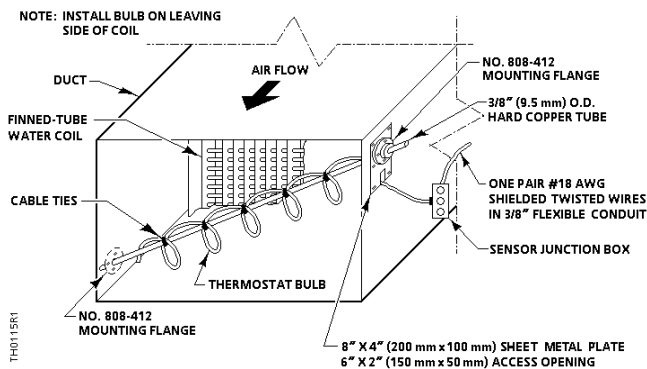

Figure 1. Limited Access Duct Mounting Option.

6. Cut a length of 3/8-inch OD hard copper tubing to fit diagonally across the duct. Insert the tube through the mounting flange on the 8 x 4-inch (200 mm x 100 mm) mounting plate. Stretch out the sensing element and fasten it to the copper tube using the cable ties.

7. Insert the tubing and attached sensing element through the access hole and into the mounting flange on the opposite side. Insert the attached sensing element through the hole located on the mounting plate.

8. Fasten the sheet metal plate to the duct. Tighten the securing screws on each of the mounting flanges.

NOTE: If leakage occurs around the sheet metal plate, use caulking, glue or liquid gasket to seal the leak.

9. Attach the junction box and conduit; pull wires and terminate (see Figure 3). Replace cover.

The installation is now complete.

NOTE: Inserting the duct sensing element into a round duct requires modification of these instructions.

Instructions for Large Walk-in Ducts Mounting Option

NOTE: The duct sensing element should be mounted in a horizontal, serpentine manner as shown in Figures 2.

1. Position and mark the screws holes for the two or more steel straps, as shown in Figure 2



CAUTION:

The wide part of the hanger strap must be parallel to the airflow in the duct to ensure minimum airflow resistance.

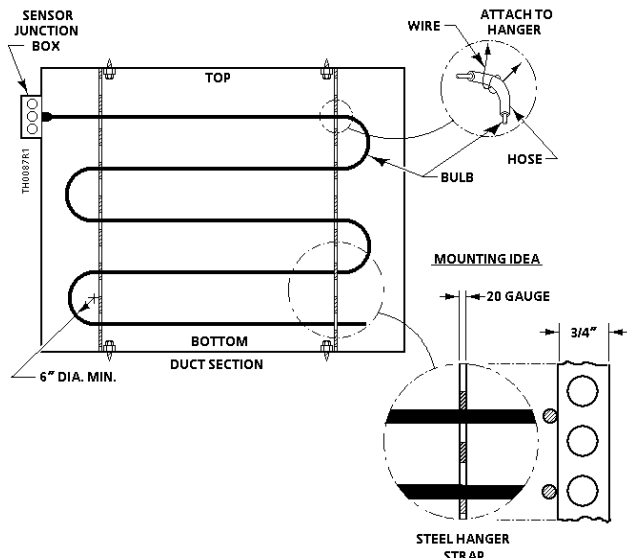

Figure 2 Large Walk-In Duct Mounting Option.

2. Use the No. 27 drill bit to drill holes for the hanger straps.
3. Mount the two perforated steel strap hangers inside the duct.
4. Position the sensor junction box on the duct and mark the four mounting holes and center hole. Use a No. 27 drill bit to drill the mounting holes and a 7/8-inch (22 mm) drill bit to drill the center hole.
5. With the sensing element still coiled, thread the sensing element through the center hole using a rotary movement.
6. When the sensing element has been completely inserted into the duct, mount the sensor junction box on the duct.
7. Carefully uncoil the sensing element, avoiding sharp bends or kinks.



CAUTION:

When uncoiling the sensing element, do NOT severely bend or kink the element. The diameter of any bend should be no less than six inches (152 mm).

8. Attach the junction box and conduit; pull wires and terminate (see Figure 3).

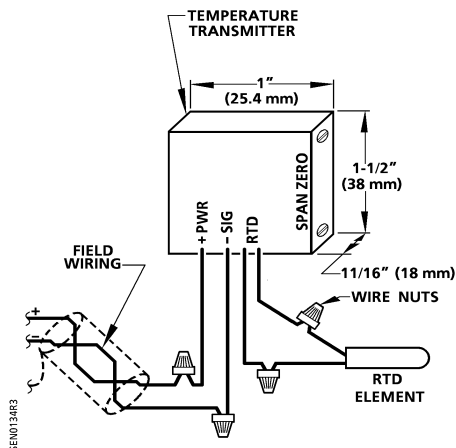

Figure 3. Analog Temperature Transmitter Wiring Connections.

NOTE: For individual panel wiring details, see the appropriate hardware manual.

9. Strip the field wires with wire cutters and connect the positive (+) 26V lead wire to the transmitter's PWR wire. Connect the signal lead wire to the transmitter's SIG wire. See Figure 3 and Table 1.
10. Replace the 2-inch x 4-inch electrical box cover on the transmitter assembly box.

The installation is now complete.

Table 1 Transmitter Lead Wire Color Codes.

Terminal	PWR	SIG	RTD	
Option 1	Red	Brown	Black	Orange
Option 2	Red	Black	White	White

- NOTE:**
1. Wire colors vary by transmitter supplier.
 2. The 4 to 20 mA transmitter located in the sensor junction box must be within an ambient temperature of 32°F to 122°F (0°C to 50°C) and 5 to 99% rh. If local conditions exceed these requirements, relocate the transmitter to an area that meets the ambient requirements.
 3. The transmitter can be connected to the RTD element over a distance of up to 25 feet (7.5 m) using a shielded twisted pair of 16 AWG wires which results in a +1°F (0.56°C) error.

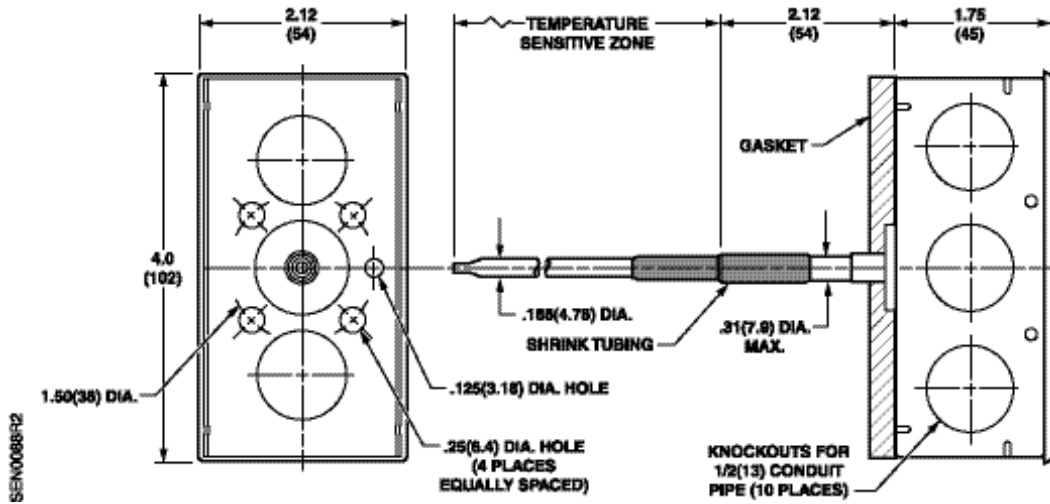

Figure 4 Mounting Hole Locations and Dimensions of Sensor Junction Box.

Information in this publication is based on current specifications. The company reserves the right to make changes in specifications and models as design improvements are introduced. Products or company names mentioned herein may be the trademarks of their respective owners.
 © 2009 Siemens Industry, Inc.