

## Diaphragm Replacement Kit for Flowrite™ AP 599 Series 8-inch Pneumatic Valve Actuator

### Product Description



This kit contains one diaphragm to replace the diaphragm in a Flowrite AP 599 Series 8-inch Pneumatic Valve Actuator.

### Product Numbers

599-01060 Normal duty diaphragms

599-01061 High temperature diaphragms

### Warning/Caution Notations

<b>WARNING</b>		Personal injury/loss of life may occur if a procedure is not performed as specified.
<b>CAUTION</b>		Equipment damage, or loss of data may occur if the user does not follow procedure as specified.

### Required Tools

- 1/2-inch socket or open end wrench
- 3/4-inch open end wrench

### Expected Installation Time

50 minutes to replace actuator diaphragm

### Prerequisites

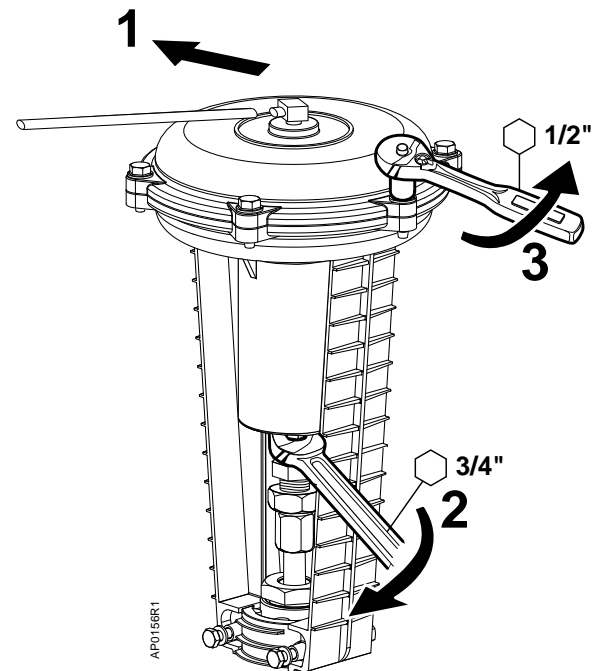
Note the start point pressure before relieving the spring tension.



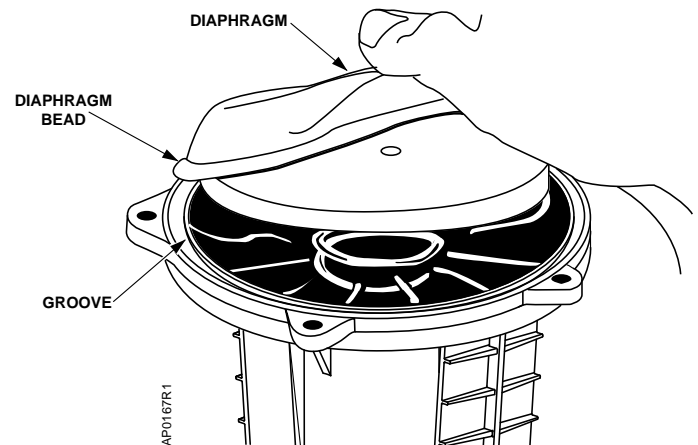
**WARNING:**

Relieve all spring tension before removing the actuator upper housing. See *Step 2* in *Figure 1*.

### Installation



**Figure 1. Removing the Actuator Upper Housing.**

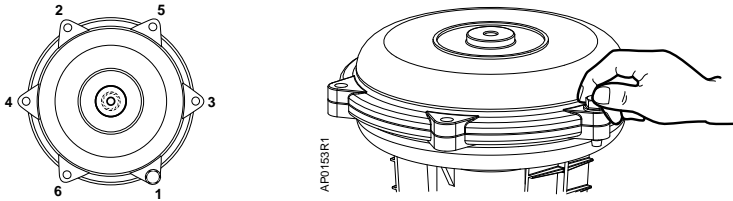


**Figure 2. Removing and Replacing the Diaphragm.**

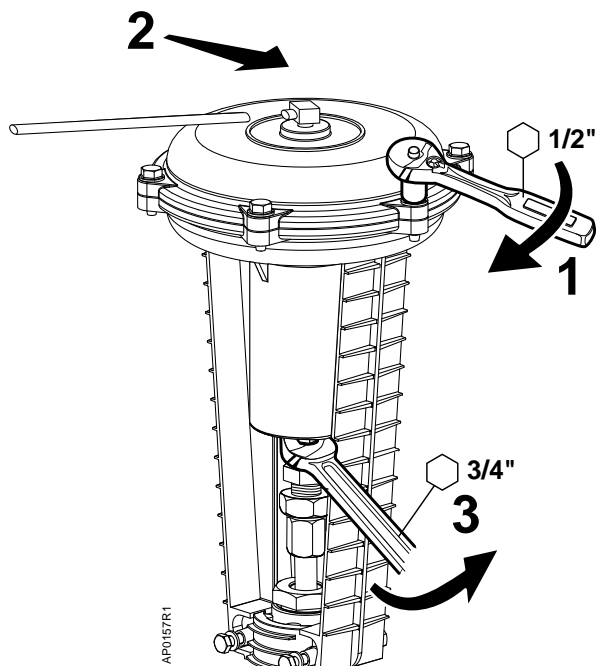
Make sure the new diaphragm bead fits in the groove of the actuator lower housing.

## Installation, Continued

Follow the pattern shown in *Figure 3* for tightening the screws.

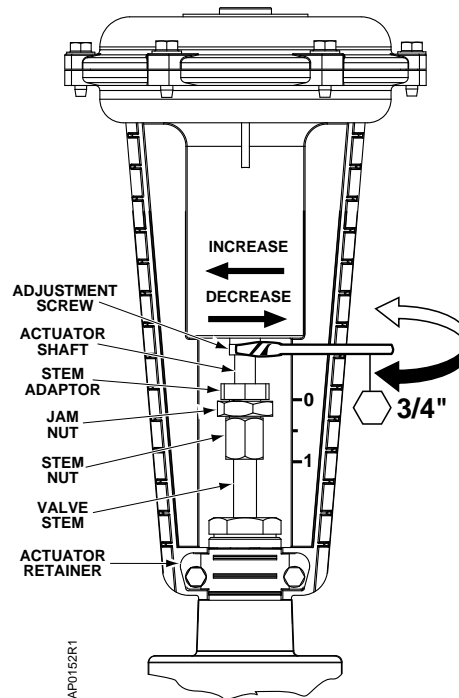


**Figure 3. Assembling the Upper and Lower Housing.**



**Figure 4. Returning the Actuator to Service.**

Adjust the spring tension to the original start point noted in the prerequisites.



**Figure 5. Spring Adjustment.**

### Spring adjustment

The top edge of the stem nut measures the valve stem position. The "0" marking on the actuator yoke indicates stem up position. The "1" mark indicates stem down position.

With the actuator in an upright position and the stem visible as shown in *Figure 5*, use a 3/4-inch open end wrench to turn the adjustment screw.

- For Normally Open Valves: To increase the start to close pressure, turn the adjustment screw from right to left. To decrease, turn the adjustment screw from left to right.
- Normally Closed Valves: To increase the start to open pressure, turn the adjustment screw from right to left. To decrease, turn the adjustment screw from left to right.

**NOTE:** As the line pressure differential across the valve increases, the spring span will decrease.

The installation is now complete.