



Data sheet

Thermo. operated water valve

AVTA



Thermo. operated water valves are used for proportional regulation of flow quantity, depending on the setting and the sensor temperature.

The Danfoss range of thermo. operated water valves includes a series of products for both refrigeration and heating regulation.

The valves are self-acting, i.e. they operate without the supply of auxiliary energy such as electricity or compressed air.

The required temperature is maintained constant without unnecessary use of:

- cooling water in cooling systems,
- hot water or steam in heating systems.

The operating economy and efficiency are maximized.

AVTA SS for aggressive media.

A valve body in stainless steel means that the valve can be used for aggressive media in such applications as the marine sector and the chemical industry.

Features

- Insensitive to dirt
- Insensitive to water pressure
- Needs no power supply – self acting
- Opens on rising sensor temperature
- Differential pressure: 0 – 145 psi
- Maximum working pressure (MWP): 232 psi
- Maximum test pressure: 365 psi
- Maximum pressure on sensor: 365 psi
- Stainless steel version available
- The valves are pressure-relieved, i.e. the degree of opening is not affected by differential pressure Δp (pressure drop).
- The regulation range is defined for the point at which the valve begins to open.
- Cooling media temperature range: -13 – 266 °F
- Ethylene glycol as a cooling media up to 40%

How it works

Thermo. operated water valves consist of three main elements:

1. Setting section with knob, reference spring and setting scale.
2. Valve body with orifice, closing cone and sealing elements.
3. Hermetically sealed thermostatic element with sensor, bellows and charge.

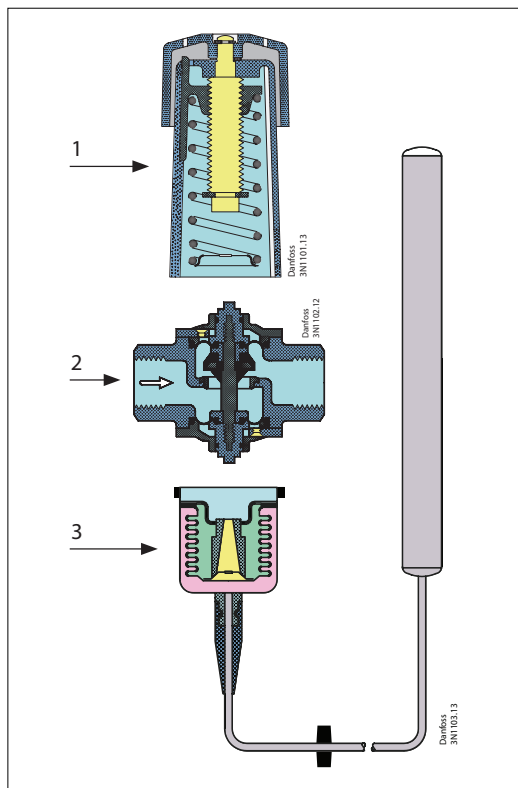

When the three elements have been assembled together, the valve installed and the sensor located at the point where the temperature is to be regulated, the function sequence is as follows:

1. The pressure changes in the sensor as a result of a change in temperature - builds up in the sensor.
2. This pressure is transferred to the valve via the capillary tube and bellows and acts as an opening or closing force.
3. The knob on the setting section and the spring exert a force that acts counter to the bellows.
4. When balance is created between the two opposing forces, the valve spindle remains in its position.
5. If the sensor temperature changes – or if the settings are changed – the point of balance becomes displaced and the valve spindle moves until balance is re-established, or the valve is fully open or closed.
6. The flow quantity change is approximately proportional to sensor temperature change.

The illustrations show an AVTA cooling water valve, but the function principle applies to all types of thermostatic valves.

AVTA applications



AVTA thermo. operated water valves are widely used for temperature regulation in many different machines and installations where cooling is required. AVTA cooling water valves always open to admit flow on rising sensor temperature.

The valve can be installed in either the cooling water flow line or the return line.

The standard version of the AVTA thermo. operated water valve can be used with fresh water or neutral brine.

Typical application areas:

- Injection moulding machines
- Compressors
- Vacuum pumps
- Dry cleaning machines
- Distillation plants
- Printing machines
- Hydraulic systems
- Roller mills
- Biomass boilers
- Industrial lasers
- Steam sterilizers
- Medical equipment
- Food processing

1. Oil tank
2. Hydraulic machinery
3. Heat exchangers
4. Cooling water supply
5. AVTA thermostatic valve

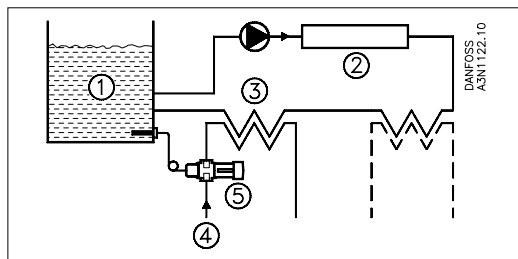

Materials

AVTA

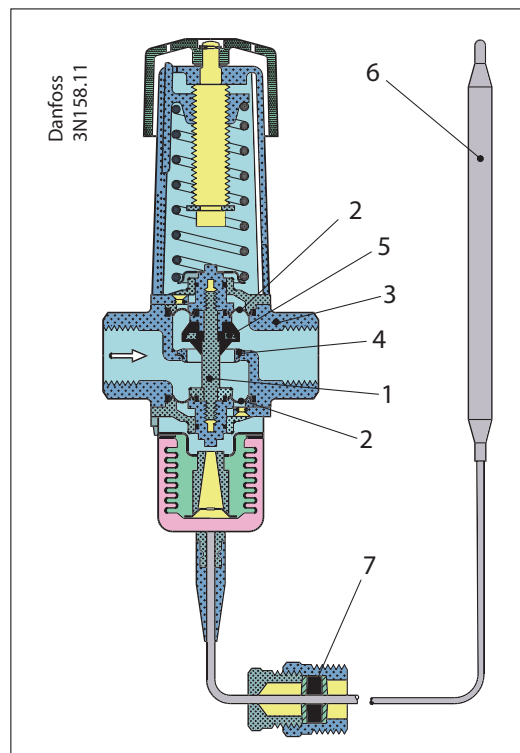

No.	Description	Material AVTA	Material AVTA SS
1	Spindle	Brass	Stainless steel
2	Diaphragms	Rubber – ethylene – propylene (EPDM).	
3	Valve body and other metal parts	Forged brass	Stainless steel
4	Valve seat	Stainless steel	
5	Valve cone	Nitrile rubber (NBR)	
6	Sensor	Copper	
7	Capillary tube gland	Nitrile rubber (NBR) / brass	

Charges

AVTA thermo. operated water valves with different types of charge



Data sheet | Thermo. operated water valve, AVTA

Ordering AVTA with adsorption charge

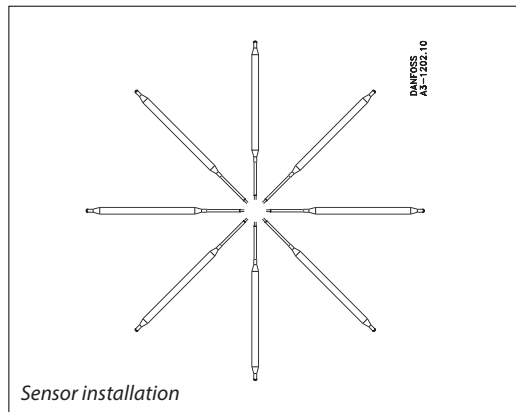

The charge consists of active carbon and CO₂ which is adsorbed on falling sensor temperature, thereby producing a pressure change in the element.

- Wide regulating range
- Can be installed in any position as far as orientation and temperature are concerned
- Small sensor dimensions – $\varnothing 0.4 \times 5.9$ in
- Max. pressure on sensor 365 psi

For immersion pockets, see “Spare parts and accessories”, page 8.

Connection NPT [in]	Regulating range	Max. temp. sensor	k _v value	Capillary tube length	Type	Code no. ¹⁾
	[°F]	[°F]	US [gpm]	[ft]		
½ - 14	50 – 176	266	2.2	7.6	AVTA 15	003N6115
¾ - 14	50 – 176	266	4.0	7.6	AVTA 20	003N7120
1 - 11 ½	50 – 176	266	6.4	7.6	AVTA 25	003N8125

¹⁾ Code no. covers complete valve incl. capillary tube gland.

Data sheet | Thermo. operated water valve, AVTA

Ordering AVTA with universal charge

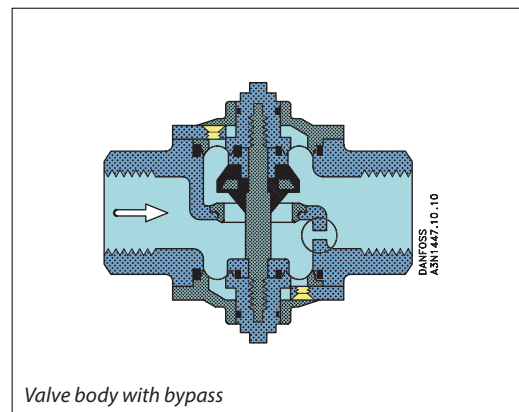
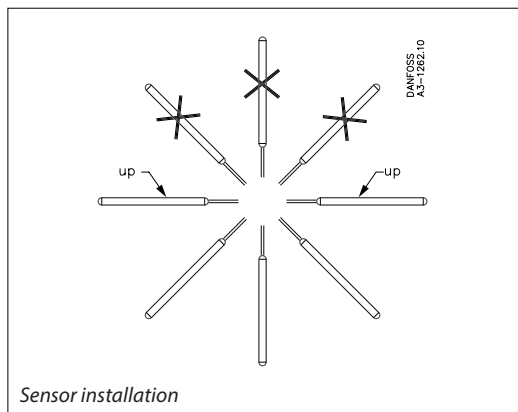

The charge is a mix of liquid and gas where the liquid surface (regulating point) is always inside the sensor. Which charge medium is used depends on the regulation range.

- Sensor dimensions $\varnothing 0.7 \times 8.3$ in
- Sensor can be installed in a place where it is either colder or warmer than the valve
- Sensors must be orientated as shown in the sketch below
- Max. pressure on sensor 365 psi

For immersion pockets, see "Spare parts and accessories", page 8.

Connection NPT [in]	Regulating range	Max. temp. sensor	C _v value	Capillary tube length	Type	Code no. ¹⁾
	[°F]	[°F]	US [gpm]	[ft]		
½ - 14	32 – 86	135	2.2	6.6	AVTA 15	003N6132
1 - 11 ½	32 – 86	135	6.4	6.6	AVTA 25	003N8132
½ - 14	77 – 149	194	2.2	6.6	AVTA 15	003N6162
¾ - 14	77 – 149	194	4.0	6.6	AVTA 20	003N7162
1 - 11 ½	77 – 149	194	6.4	6.6	AVTA 25	003N8162
½ - 14	122 – 194	257	2.2	6.6	AVTA 15	003N6182
¾ - 14	122 – 194	257	4.0	6.6	AVTA 20	003N7182
1 - 11 ½	122 – 194	257	6.4	6.6	AVTA 25	003N8182

¹⁾ Code no. covers complete valve incl. capillary tube gland.

Ordering AVTA with mass charge

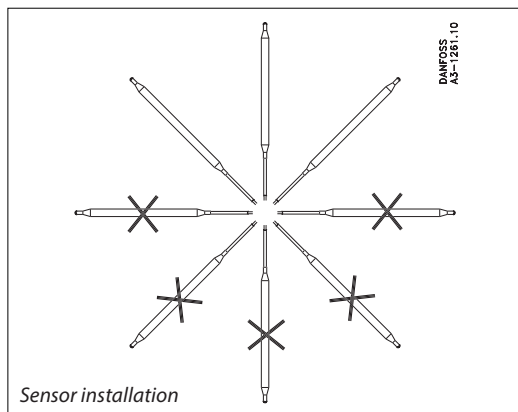

The charge is a mix of liquid and gas. Due to the mixture of liquid and gas the sensor must be installed in an area or environment that is warmer than the valve.

- Small sensor dimensions – $\varnothing 0.4 \times 7.5$ in
- Short time constant
- Max. pressure on sensor 365 psi
- Only codes with G thread available

Connection ¹⁾	Regulating range	Max. temp. sensor	C _v value	Capillary tube length	Type	Code no. ¹⁾
	[°F]	[°F]	US [gpm]	[ft]		
G 1/2	32 – 86	135	2.2	6.6	AVTA 15	003N0042
G 3/4	32 – 86	135	4.0	6.6	AVTA 20	003N0043
G 1/2	32 – 86	135	6.4	6.6	AVTA 15	003N0045
G 1/2	77 – 149	194	2.2	6.6	AVTA 15	003N0034
G 3/4	77 – 149	194	4.0	6.6	AVTA 20	003N0046
G 1	77 – 149	194	6.4	6.6	AVTA 25	003N0047

¹⁾ Code no. covers complete valve incl. capillary tube gland.

Data sheet | Thermo. operated water valve, AVTA

Ordering AVTA in Stainless Steel with adsorption charge

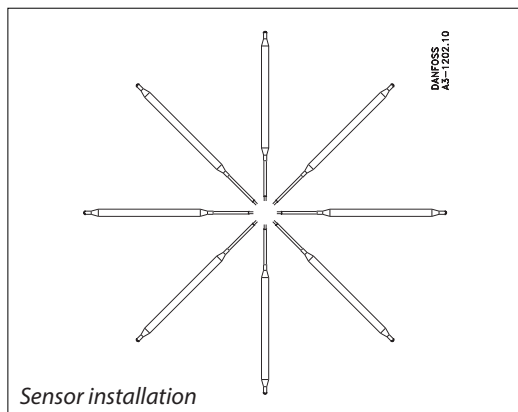

- Wide regulating range
- Can be installed in any position as far as orientation and temperature are concerned
- Small sensor dimensions – $\varnothing 0.4 \times 5.9$ in
- Max. pressure on sensor 365 psi
- AVTA SS mass and universal charges available on request
- Only codes with G thread available.



For immersion pockets, see “Spare parts and accessories”, page 8.

Connection ¹⁾	Regulating range	Max. temp. sensor	C _v value	Capillary tube length	Type	Code no. ¹⁾
	[°F]	[°F]	US [gpm]	[ft]		
G 1/2	50 – 176	266	2.2	7.6	AVTA 15	003N2150
G 3/4	50 – 176	266	4.0	7.6	AVTA 20	003N3150
G 1	50 – 176	266	6.4	7.6	AVTA 25	003N4150

¹⁾ Code no. covers complete valve incl. capillary tube gland.

Data sheet | Thermo. operated water valve, AVTA

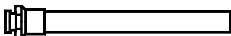
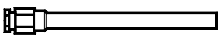
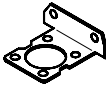
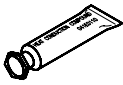
Accessories

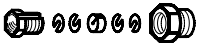
	Designation	Description	Code no.
		Brass for $\varnothing 0.7$ in, sensor $\frac{3}{4}$ – 14 NPT	003N0051
		18/8 steel ¹⁾ for $\varnothing 0.7$ sensor, $\frac{3}{4}$ – 14 NPT	003N0053
	Immersion sensor max. pressure 725 psi L = 7.2 in	Brass for $\varnothing 0.4$ sensor G $\frac{1}{2}$	017-436766
		18/8 steel ¹⁾ for $\varnothing 0.4$ sensor R $\frac{1}{2}$	003N0196
	Mounting bracket	For AVTA	003N0388
	Heat-conductive compound	0.01 lbs tube	041E0110
		1.75 lbs	041E0111
	Set of 3 nitrile (NBR) diaphragms sets for mineral oil	For AVTA 10/15, 20, 25	003N0448
		$\frac{1}{2}$ – 14 NPT	003N0157
		$\frac{3}{4}$ – 14 NPT	003N0056
	Plastic hand knob	For AVTA	003N0520

¹⁾W. no. 1.4301.

Spare parts

Thermostatic elements for AVTA valves

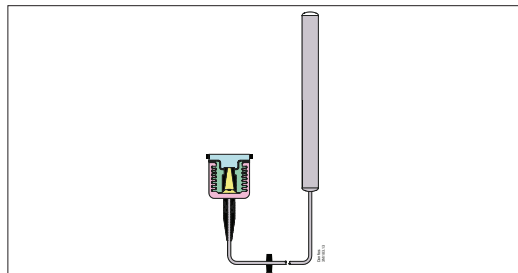

Thermostatic Elements	Temperature range	Capillary tube length	Code no.
	[°F]	[ft]	
Adsorption charge – sensor $\varnothing 0.4 \times 5.9$ in	50 – 176	7' 6"	003N0278
Universal charge – sensor $\varnothing 0.7 \times 8.3$ in	32 – 86	6' 6"	003N0075
	32 – 86	16' 5"	003N0077
	77 – 149	6' 6"	003N0078
	77 – 149	16' 5"	003N0080
	122 – 194	6' 6"	003N0062
Mass charge – sensor $\varnothing 0.4 \times 7.5$ in	77 – 149	6' 6"	003N0091
	77 – 149	16' 5"	003N0068

Installation

AVTA with mounting bracket

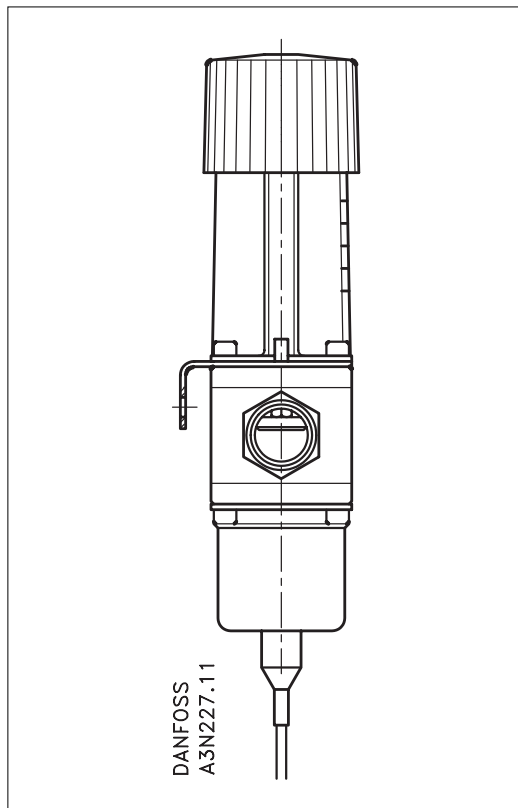

The valves can be installed in any position. An arrow on the valve body indicates the direction of flow.

AVTA valves are marked so that the letters RA are the right way up when the valve is held as shown. The installation of an FV filter ahead of the valve is recommended.

Capillary tube

Install the capillary tube without sharp bends (no "kinks"). Make sure that there is no strain on the capillary tube at the ends. Relief is important where vibration might occur.

Note:

When an AVTA valve is used, the sensor must be able to react to variations in cooling water temperature on system start. Therefore a bypass line with a shut-off valve might be necessary to ensure flow at the sensor during start-up. If a mounting bracket is used – see "Spare parts and accessories", page 10 – it must always be positioned between the valve body and the setting section (see illustration).

Sizing

When sizing and selecting thermo. operated water valves, it is most important to ensure that the valve is able to give the necessary quantity of cooling water at any time, irrespective of the load. Therefore, to select a suitable size of valve it is necessary to know the precise amount of cooling required. On the other hand, to avoid the risk of unstable regulation (hunting), the valve should not be oversized.

The type of charge must be selected on the basis of the temperature to be maintained, and on an assessment of the characteristics of each type, as described in the foregoing.

In general the aim should be to select the smallest valve capable of giving the required flow.

It is also recommended that the temperature range be chosen so that the required sensor temperature lies in the middle of the regulation range.

To help fine-setting the valve, a thermometer should be installed near the sensor.

Example

A cooling water valve must be selected for the temperature regulation of a vacuum pump.

Since direct regulation of the oil temperature is required, an AVTA valve is suitable.

The sensor position is horizontal – and small dimensions are desired.

Given data:

- Necessary cooling at full load 5 TR.
- Oil temperature to be maintained constant at 113 °F
- Cooling water $p_1 = 60$ psi
- Outlet $p_3 = 0$ psi
- $p_2 = \frac{p_1 + p_3}{2}$ (guess)
- Cooling water temperature $t_1 = 88$ °F
- Outlet temperature $t_2 = 68$ °F

1. Using the graph in fig.1, you find the necessary cooling water quantity at $\Delta t = 20$ °F (88 – 68 °F) for 6 US [gpm].
2. Using the graph in fig. 2, you find the necessary C_v -value for 6 US [gpm] at $\Delta p = 30$ psi $(60 - 0)/2$ for 1.17 US [gpm].
3. It can be seen from the columns in fig.2 that all three AVTA valves can be used, but the preferable selection is a valve where the necessary C_v -value lies in the middle of the range. So in practice an AVTA 15 ought to be selected as it fully meets the demand.

Valve size

The following data are used when selecting the valve size:

- Required cooling water flow, Q [US [gpm]]
- Temperature rise in cooling water, Δt [°F]
- Differential pressure across valve, Δp [psi].

With fully open valve, the differential pressure should be around 50% of the total pressure drop across the cooling system.

The charts on page 12 are intended to make valve sizing easier.

Fig. 1 – Relation between heat quantity [kW] and cooling water quantity

Fig. 2 – Graphs of C_v values

Fig. 3 – Valve operating range

Fig. 4 – Flow quantities as a function of pressure drop Δp

Operating conditions and other product requirements in this example mean that a valve with adsorption charge is the correct choice.

The temperature range 50 – 176 °F is in order.

The table on page 4 gives AVTA 15, code no. **003N6115**, which fulfill the requirements. To facilitate the installation a sensor pocket is often used. A sensor pocket for $\varnothing 0,4$ " sensor in brass, code no. **017-436766**, or in stainless steel, code no. **003N0196**, is listed under "Accessories" on page 10.

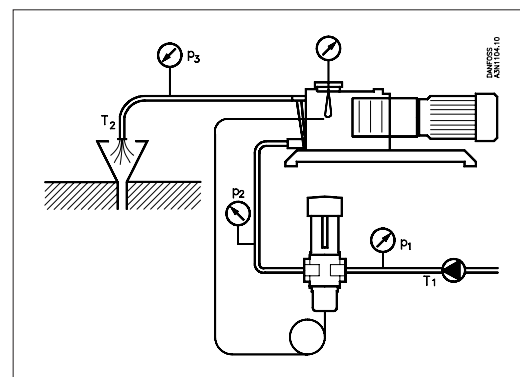

Sizing
(continued)

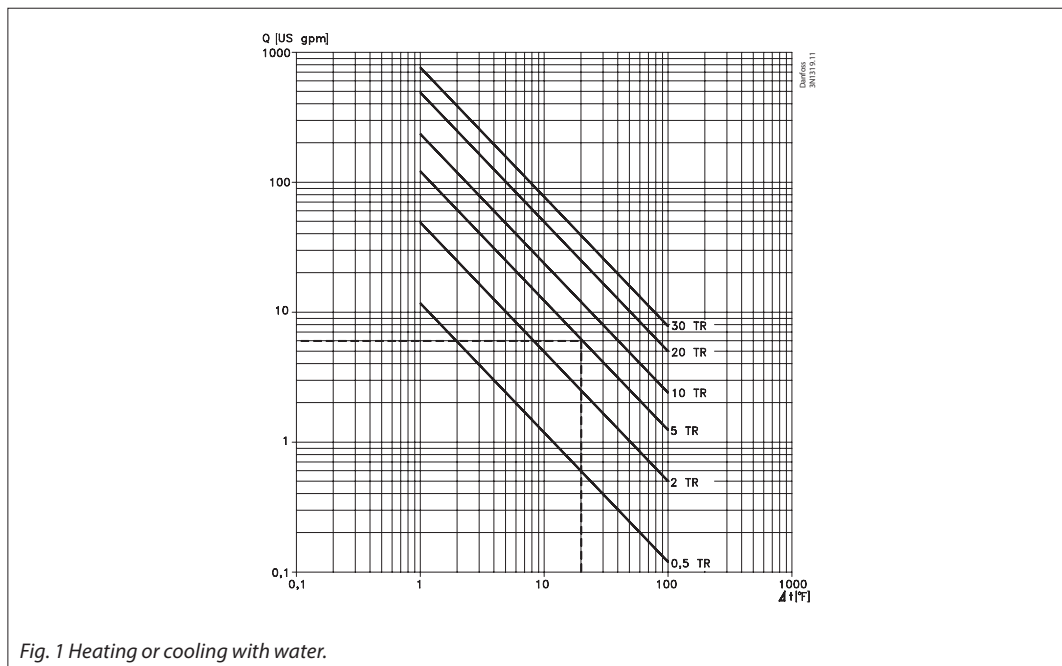

Fig. 1 Heating or cooling with water.

Example:
Necessary cooling output 5 TR with $t = 20\text{ }^{\circ}\text{F}$.
Required flow is 6 US [gpm].

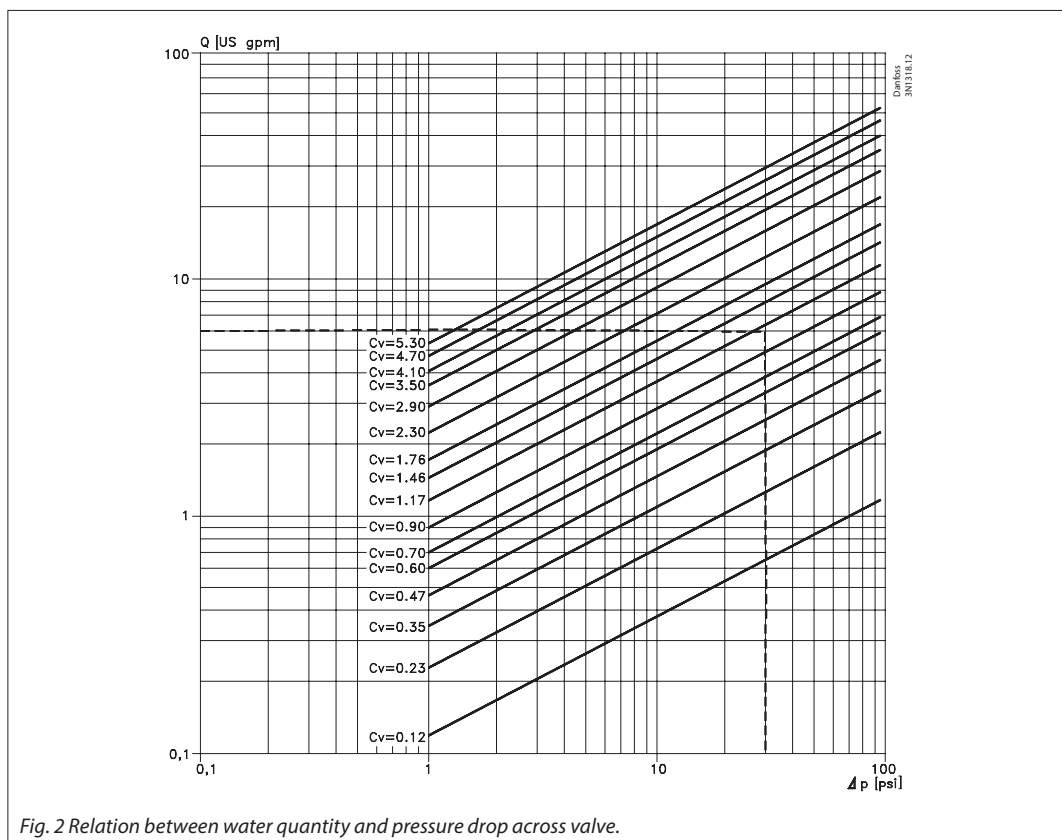

Fig. 2 Relation between water quantity and pressure drop across valve.

Example:
Flow 6 US gpm with a pressure drop of 30 psi.
The C_v value becomes 1.17 US [gpm].

Data sheet | Thermo. operated water valve, AVTA

Sizing
(continued)

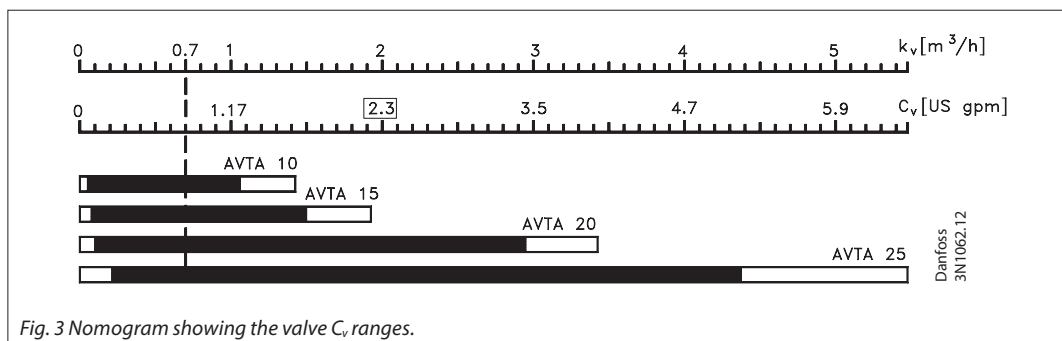

Fig. 3 Nomogram showing the valve C_v ranges.

C_v values are always water flow in US gpm for a pressure drop Δp of 1 psi. The preferable selection is a valve where the necessary C_v -value lies in the middle of the range, as a valve with a C_v -value close to either the max. or min. value is less stable and less precise due to either a relatively large Δp or ΔQ .

Example:
AVTA 10 and 15 are the most suitable for a C_v value of 1.17 US [gpm].

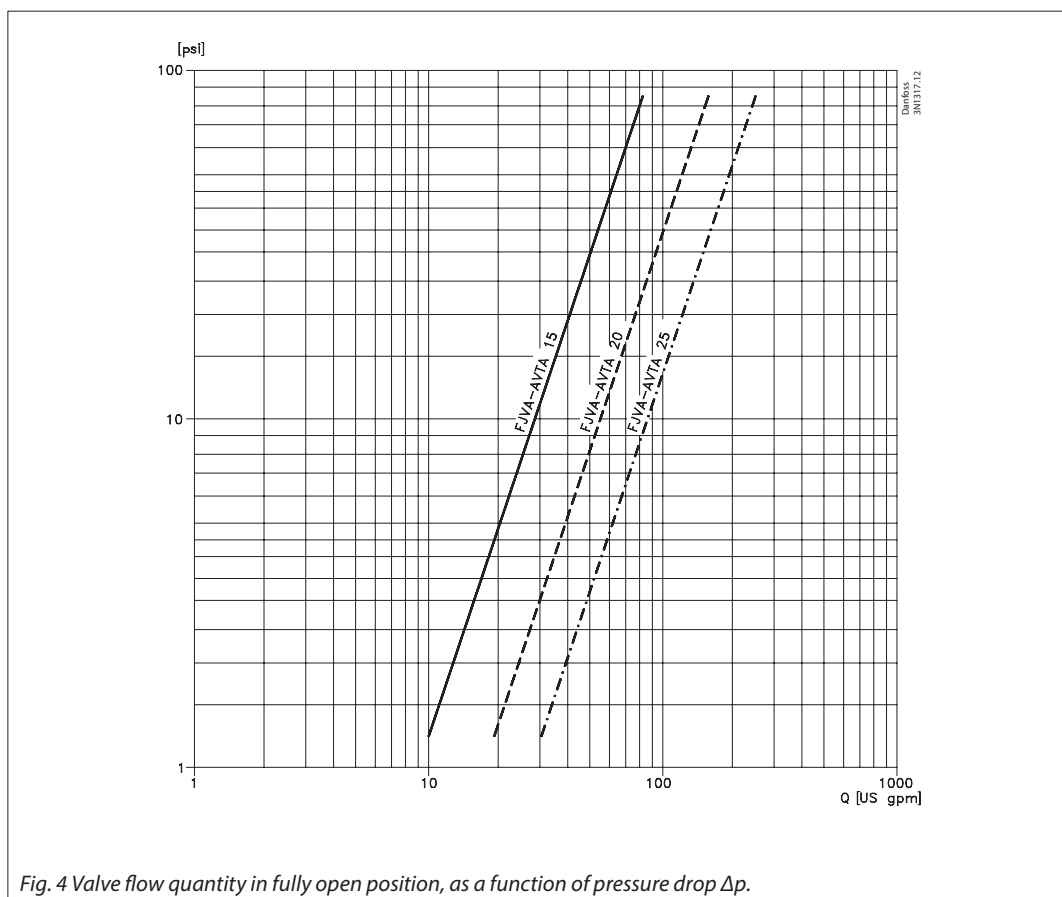
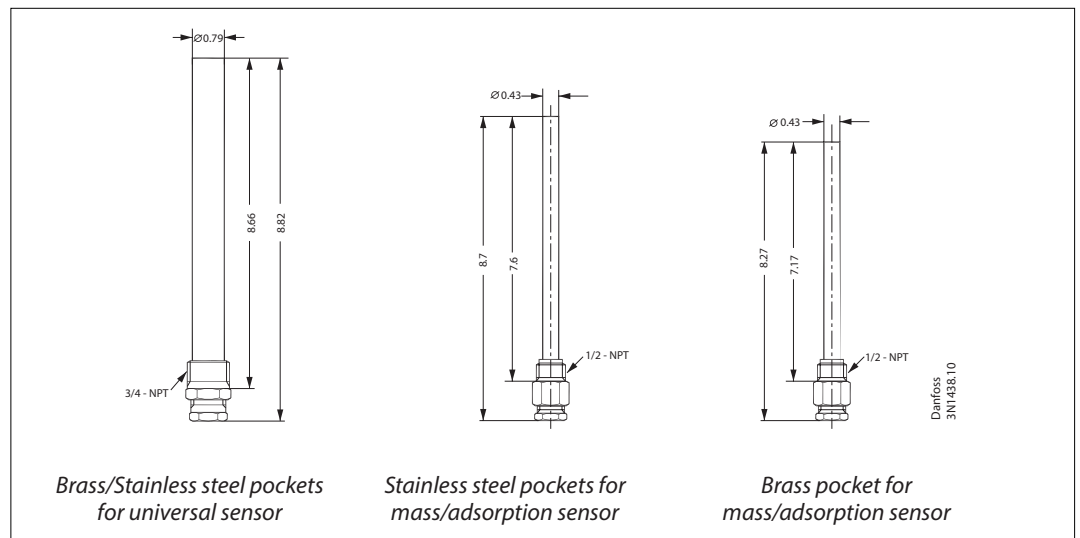
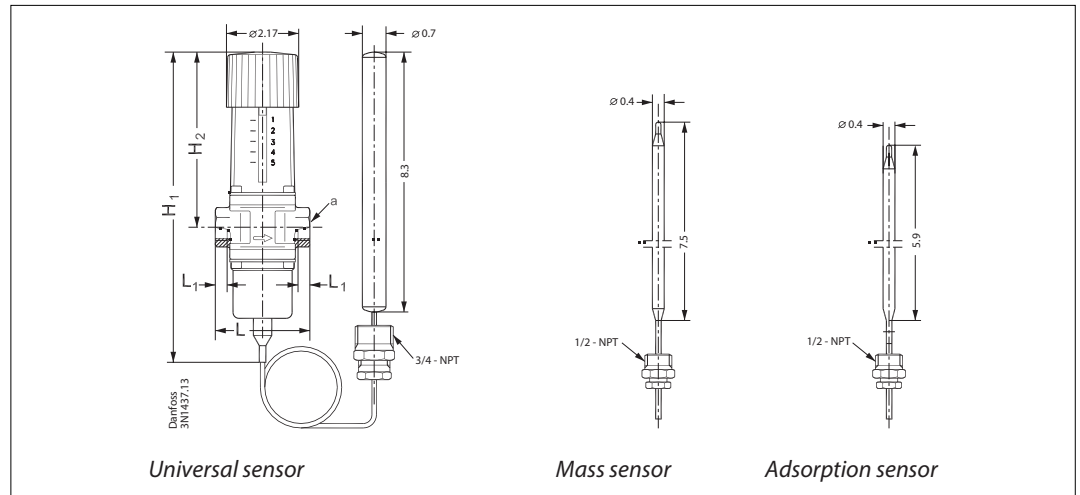

Fig. 4 Valve flow quantity in fully open position, as a function of pressure drop Δp .

Options

- DZR brass
- Outer thread connecting
- Other lengths of capillary tubes
- Armouring of capillary tubes
- Other combinations of sizes, materials and ranges
- NPT – connection, see separate datasheet for USA / Canada

Dimensions [in] and weights [lbs] of AVTA valves in brass and stainless steel housings



Type	H ₁	H ₂	L	L ₁	a	Net weight
AVTA 15	9.45	5.24	2.84	0.56	G 1/2	3.20
AVTA 20	9.45	5.24	3.55	0.63	G 3/4	3.31
AVTA 25	9.85	5.43	3.74	0.75	G 1	3.64