

## Table of Contents

PRODUCT	PRODUCT CODE	TECHNICAL INSTRUCTIONS	PAGE #
<b>Switches</b>			
Selector Switches	SW 786	155-118P25	G-3
Positioning Switch	SW 141	155-117P25	G-5
Enthalpy Control Switch	EE 141	155-054P25	G-7
Static Pressure Switch	SW 269	155-061P25	G-9
Differential Static Pressure Airflow Switches	SW 141	155-052P25	G-11
Pressure Electric Switches	PE 134	155-050/051/057P25	G-13
Three-way EP Valves	EP 265	155-078P25	G-15
<b>Pneumatic Relays</b>			
Multi-purpose Relay	RL 243	155-042P25	G-17
Balance-retard Relay	RL 243	155-106/043P25	G-19
Analog Relay	RL 243	155-107/044P25	G-21
Switching Relay	RL 243	155-040P25	G-23
Reverse Acting Relay	RL 243	155-124P25	G-25
Highest Pressure Signal Selector	RL 243	155-045P25	G-27
Lowest and Highest Signal Selector	RL 243	155-046P25	G-29
Lowest Pressure Signal Selector	RL 243	155-047P25	G-31
Positioning Relay	RL 147	155-038P25	G-33
<b>Pneumatic Equipment</b>			
Electronic-to-Pneumatic Transducer	EP 545	149-277P25	G-35
<b>Accessories and Service Kits</b>			G-37

**Standard Shipping within 3 to 5 days** Products ordered through the Rapid Response™ program can ship same day. Expect longer lead times for large quantities and unique parts. See inside back cover for details on Rapid Response™ shipping.

## Save trees with paperless invoicing

Once your order has been shipped, an invoice will be sent to you via e-mail, so you can conserve paper while avoiding the hassles of paperwork.



# Selector Switches

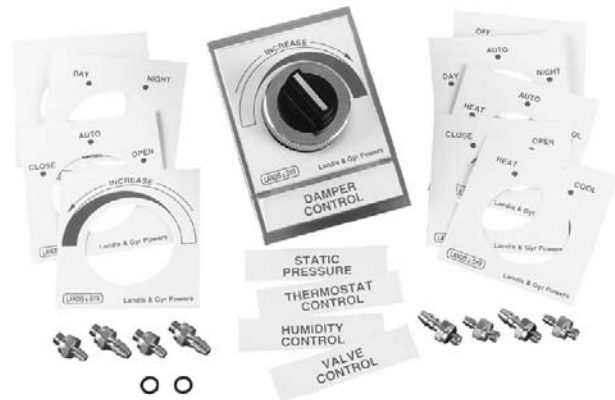

Floating Selector Switch.

## Description

The 786 Selector Switch is used to deliver or stop the flow of compressed air to selected controllers valves, or dampers in commercial applications.

The common port may be connected to two or three ports depending on the switch model.

## Features

- Compact design and lightweight construction
- Click stop for positive positioning
- Easy panel mounting through 1-7/32-inch (31 mm) diameter knockout
- 10-32 Female connection ports
- Dial label and nomenclature sheets for most applications
- Barb fitting for 5/32-inch (4 mm) OD tubing for port connections

## Applications

The 786 floating Selector Switch is used in compressed air systems to connect and direct supply and signal pressures. Typical applications are OPEN/CLOSE damper position, DAY/NIGHT thermostat operation, and ON/OFF/AUTO system operation. The compact design makes these especially adaptable to panel groupings.

### Application Drawing

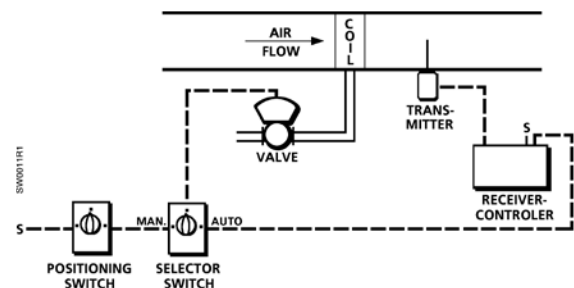

Standard and Large Capacity.

### Typical Connections

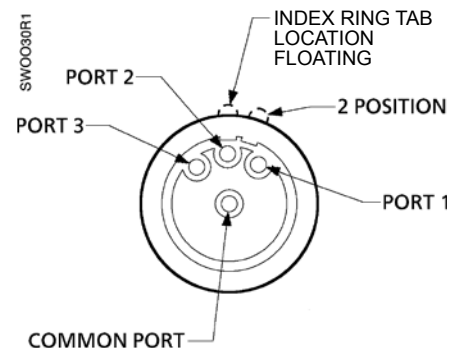

2- and 3-position Selector Switch.

## 786 Selector Switches Specifications

Medium .....	Air
<b>Air Connections</b>	
Standard Switch .....	1/16" NPT
LC Switch .....	1/8" NPT
<b>Inlet Pressure</b>	
Nominal .....	30 psi (206 kPa)
Maximum .....	125 psi (858 kPa)
<b>Operating Temperature</b> .....	35 to 150°F (2 to 66°C)

<b>Capacity at 1 psi (7 kPa) Differential</b>	
5/32" (4 mm) OD tubing .....	250 scim (68 ml/s)
1/4" (3 mm) OD tubing .....	480 scim (130 ml/s)
<b>Port Threads</b> .....	10-32 NPT female
<b>Materials</b>	
Body .....	Acetal
O-rings .....	Buna N

## 786 Selector Switches Product Ordering

Description	Part No.
2-position	786-0600
Floating	786-0610

### Accessories & Service Kits G-38

## Dimensions

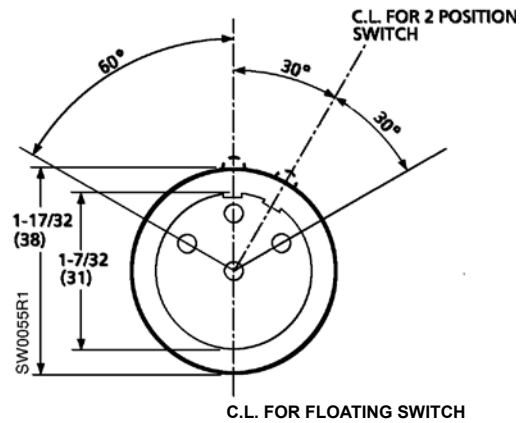
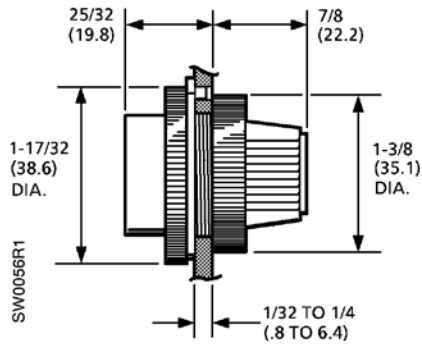

Dimensions shown in inches (mm).

## Positioning Switch

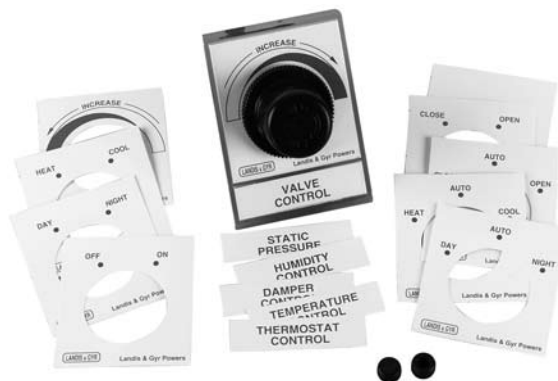

141 Positioning Switch.

### Description

The 141 Positioning Switch is used to deliver any manually selected pressure over a range of 0 to 30 psi (0 to 207 kPa) to air-operated equipment. The adjustment knob can be left free to rotate or held in position by snapping the locking ring.

### Features

- Compact design and lightweight construction
- Non-rising low torque pressure adjustment knob with snap-action locking ring for maintaining pressure setting
- Available in manual select or bleed type models
- Easy to surface or panel mount
- Easy panel mounting through 1-7/32" (31 mm) diameter knockout
- Includes dial label and nomenclature sheet for most applications

### Applications

The 141 Positioning Switch is used in compressed air systems to maintain a uniform outlet pressure despite changes in the inlet pressure and changes in downstream flow requirements; especially suited for installations where space is limited and where panel mounting with a flush-mount knob is desired.

G-5

Switches & Relays

## 141 Positioning Specifications

**Medium** ..... Air  
**Air Connections** ..... 1/8" NPT female  
**Inlet Pressure**  
 Nominal ..... 30 psi (206 kPa)  
 Maximum ..... 400 psi (2745 kPa)

**Operating Temperature** ..... 0 to 150°F (-18 to +66°C)  
**Capacity at 1 psi (7 kPa) Differential**  
 5/32" (4 mm) OD tubing ..... 500 scim (140 ml/s)  
 1/4" (6 mm) OD tubing ..... 650 scim (180 ml/s)  
**Shipping Weight** ..... 0.5 lb. (0.23 kg)

## 141 Positioning Product Ordering

Description	Part No.
Positioning Switch	141-0600

### Accessories & Service Kits

G-38

## Dimensions

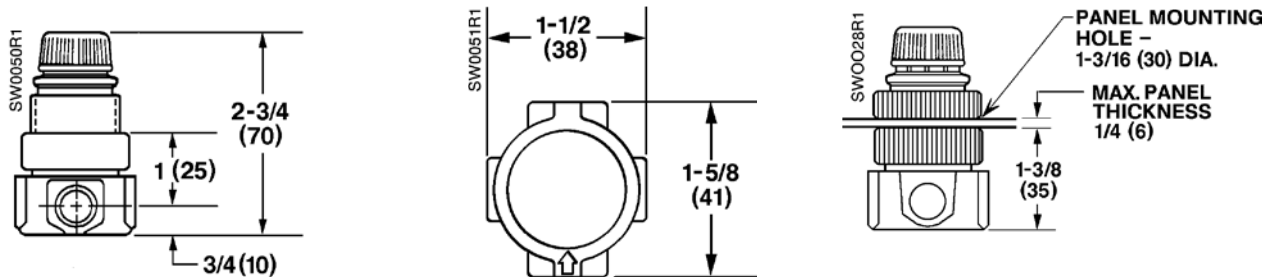

Dimensions shown in inches (mm).

G-6

Switches & Relays

## Electric Enthalpy Control Switch



141 Enthalpy Control Switch.

### Description

The 141 Electric Enthalpy Control Switch is designed to sense the BTU heat content of ventilation air. A SPST, snap-acting electric switch automatically initiates corrective damper control or alarm circuitry whenever the sensed air condition either rises above or falls below desired settings.

### Features

- SPST, snap-acting switch
- Direct mount on ventilation duct
- Mounting template and screws provided
- Factory-calibrated
- Adjustable

### Applications

The 141 Electric Enthalpy Control Switch senses outdoor ventilation air on air conditioning systems to automatically reduce ventilation whenever the outdoor air has a higher than desired heat content.

Reduction of outdoor air, when it has a higher heat content than return air from the interior space, provides significant load reduction and energy savings for summer air conditioning systems.

Reduction of system load also tends to improve system performance by allowing more effective space dehumidification (improved latent heat removal under light load) or by reducing the time span required to cool a space on initial starting.

## 141 Control Switch Specifications

Electrical Rating .....	2.5 amps max. @ 24 Vac
Electrical Connection .....	Metal enclosure with 1/2" (13 mm) conduit opening
Switching Action .....	SPDT
Differential .....	Approx. 8% RH and 2°F (-29°C)
Shipping Weight .....	1.5 lb. (0.7 kg)

## 141 Control Switch Product Ordering

Description	Part No.
Electric Enthalpy Control Switch	141-0566

**Accessories & Service Kits** **G-38**

## Dimensions

G-8

Switches & Relays

Electric Enthalpy Control Switch

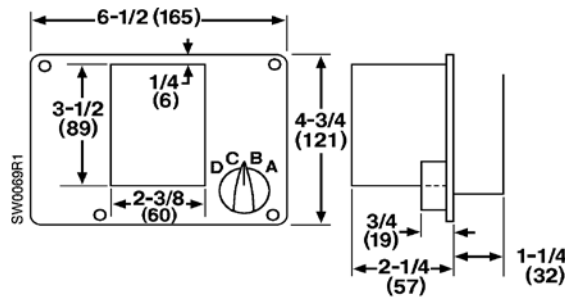

Dimensions shown in inches (mm).



# Static Pressure Switch

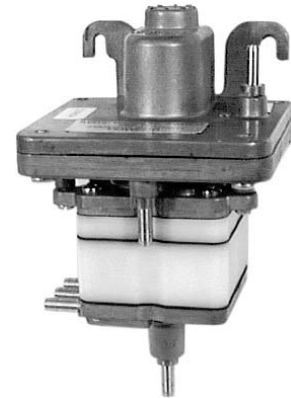

269-1200 Static Pressure Switch.

## Description

The 269 Static Pressure Switch senses static pressure and performs a three-way switching function when the specified static pressure level is reached.

## Features

- Accurate and repeatable switching thresholds
- 1/8-inch (3 mm) OD brass barb port fittings

## Applications

In a typical application, the 269 Static Pressure Switch is used to close outside air dampers when the fan is not moving any air.

G-9

Switches & Relays

### Application Drawing

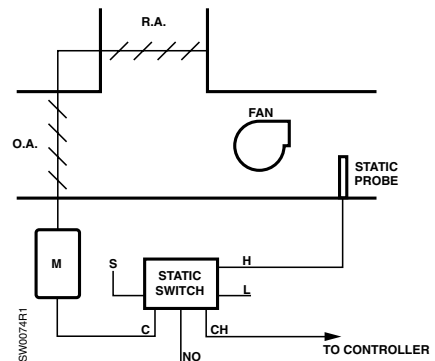

### Typical Connections

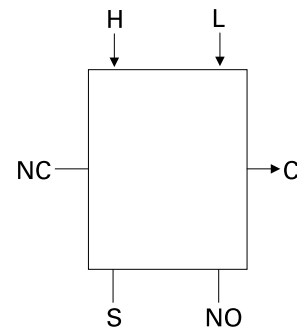

269 Static Pressure Switch.

## 269 Pressure Switch Specifications

### Switching Threshold (differential H to L)

Increasing Static to 0.25" W.G. (62.25 kPa) ..... Switches C to NC  
 Decreasing Static to 0.10" W.G. (62.25 kPa) ..... Switches C to NO

**Air Capacity @ 1 psi Pressure Drop** ..... 300 scim (82 ml/s)

**Air Supply** ..... 18 to 28 psi (124 to 193 kPa)

### Maximum Ratings Pressure

Ports S, C, NC or NO .....30 psi (206 kPa) max.  
 Ports H & L ..... 10" W.G. (2.5 kPa) max. differential

### Temperature

Operating..... 35 to 120°F (2 to 48°C)  
 Storage..... 10 to 140°F (-23 to +60°C)

**Air Consumption** ..... 30 scim (8.2 ml/s)

**Dimensions** ..... 5.20" H x 3.25" W x 3.32" D  
 (132 mm H x 83 mm W x 64 mm D)  
 2-1/2" (64 mm) mounting hole centers

**Shipping Weight** ..... 1.75 lb. (0.79 kg)

## 269 Pressure Switch Product Ordering

Description	Part No.
Static Pressure Switch	269-1200

## Accessories & Service Kits G-39

# Differential Static Pressure Airflow Switches



141 Differential Static Pressure Airflow Switches.

## Description

The 141 Airflow Switch senses static differential pressure and at setpoint open/closes a set of electrical contacts.

## Features

- Available in ranges:
  - 0.05 to 1" W.C. (12.45 to 249 Pa)
  - 1 to 12" W.C. (249 to 2988 Pa)
- Available with auto reset
- Can be used in multiple applications:
  - Proof of flow
  - High limit cut out
  - Filter 'dirty' indication

## Applications

The 141 Airflow Switch actuates electrical circuits (positive pressure), fan inlet (negative pressure), or across the fan (differential pressure) to detect excessively high positive pressures or low negative pressures and turn off the fan before damage occurs to ducts or dampers.

The manual reset switch (141-0575) should be used for applications that require safety lock out (shut down) of the fan. The switch can be used on the fan discharge.

The auto reset switch should be used for applications that require positive proof of airflow (or fan operation) or detect high differential pressures associated with dirty air filters or similar maintenance alarms that do not require safety lock or (shut down) of the fan.

G-11

Switches & Relays

### Typical Connections

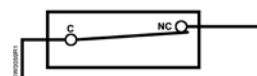

141-0575  
Manual Reset Switch.

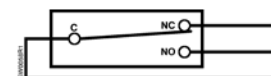

141-0518 and 141-0574  
Auto Reset Switches.

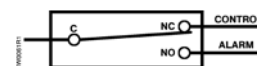

Auto Reset Switches to  
Prove Excessive Airflow  
or Pressure.

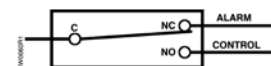

Auto Reset Switches to  
Prove Insufficient Airflow  
or Pressure.

# 141 Airflow Switches Specifications

**Medium** ..... Air  
**Switch Action Manual Reset**  
 (must be manually reset by operator)..... NC; only opens on increasing pressure signal  
**Ambient Temperature Range** ..... -40 to +180°F (-40 to +82°C)  
**Maximum Overpressure** ..... 0.5 psi (3.4 kPa)  
**Mounting Position** ..... Diaphragm in any vertical plane  
**Body** ..... Zinc-plated Steel with blue erudite dip  
**Electrical Ratings**  
 Non-inductive ..... 15 amps @ 120 to 277 Vac  
 Pilot Duty ..... 300 VA @ 120 to 277 Vac

**Conduit Opening** ..... 1/2" (13 mm) conduit size  
**Sample Line Connectors** ..... 2 connectors, complete with nuts and ferrules, which accept 1/4" (6 mm) OD copper or polyethylene tubing  
**Material** ..... Aluminized Steel  
**Agency Approvals** ..... UL MFHX File MH9888  
 CSA 1811M25  
**Dimensions** ..... 6.13" H x 3.88" W x 3.19" D  
 (156 mm H x 98 mm W x 81 mm D)  
**Shipping Weight** ..... 1.0 lb. (0.45 kg)

# 141 Airflow Switches Product Ordering

Set Point Range (Field Adjustable)	Switching Action/Reset	Factory Set Point Accuracy	Differential	Part No.
1" to 12" W.C. (250 to 3000 kPa)	SPDT/Auto Reset	1" ± 0.1" W.C. (250 kPa ± 25 kPa) to 12" ± 1.2" W.C. (3000 kPa ± 300 kPa)	0.25" W.C. (62.5 kPa) max. at 1" W.C. (25 kPa) set point to 1.2" W.C. (300 kPa) max. at 12" W.C. (3000 kPa) set point	<b>141-0518</b>
1" to 12" W.C. (250 to 3000 kPa)	SPST/ Manual Reset	1" ± 0.1" W.C. (250 kPa ± 25 kPa) to 12" ± 1.2" W.C. (3000 kPa ± 300 kPa)	Not Applicable	<b>141-0575</b>
0.05" to 1.0" W.C. (12.5 to 250 kPa)	SPDT/ Auto Reset	0.05" ± 0.02" W.C. (12.5 kPa ± 5 kPa) to 1.0" ± 0.1" W.C. (250 kPa ± 25 kPa)	0.02" W.C. (5 kPa) at min. set point 0.1" W.C. (25 kPa) at max. set point	<b>141-0574</b>



G-12

Switches & Relays

## Accessories & Service Kits G-38

## Dimensions

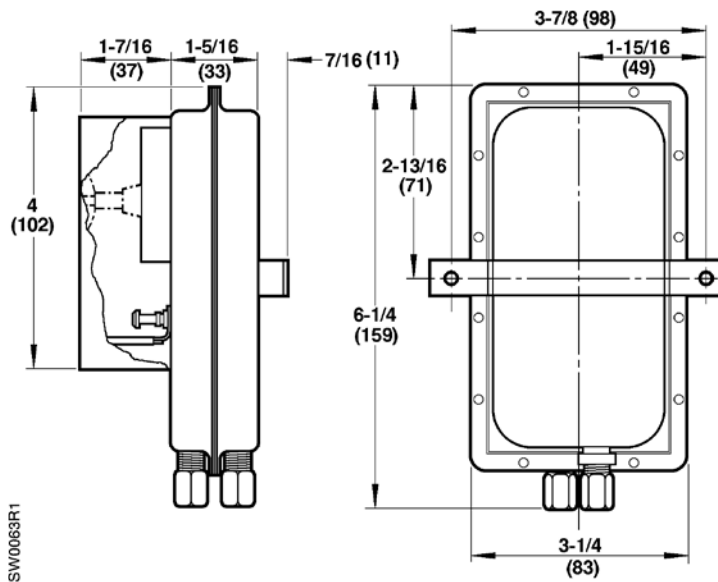

Dimensions shown in inches (mm).



Part No. in black box Ships same day when requested through Rapid Response™ shipping. See inside back cover for details.



## Pressure Electric Switch



134 Pressure Electric Switch.

### Description

The 134 Pressure Electric Switches are heavy duty pressure-actuated, mechanical contact type switches used to open or close electrical circuits from pressure signals in pneumatic control systems.

### Features

- DPST or SPDT snap-acting
- External adjustment and indication of set point and differential
- Screw terminals are easily accessible for field wiring
- Long life, heavy duty contact mechanism
- Normally open or normally closed contacts models available
- Not position sensitive, can be mounted in any position
- Mounting bracket included

### Applications

The 134 Pressure Electric Switches are used wherever it is necessary to close (or open) an electrical circuit on the basis of a predetermined air pressure signal. This switch is to be used in areas protected from the weather. Typical applications include the control of air compressors, fans, pilot lights, resistance heating elements, control of electric heating loads or motors on fans, pumps or small air compressors.

G-13

Switches & Relays

## 134 Electric Switch Specifications

Medium .....	Compressed air
Set Point Range .....	3 to 30 psi (20 to 200 kPa)
Differential .....	Adjustable from 1.5 to 20 psi (10 to 138 kPa)
Maximum Pressure .....	50 psi (345 kPa)
Pressure Connection .....	1/8" male NPT
Conduit Opening .....	1/2" (13 mm) nominal conduit
Ambient Temperature .....	32 to 140°F (0 to 60°C)
Pilot Duty	
134-1450, 134-1451 .....	125 VA @ 600 Vac
134-1460 .....	125 VA @ 24 to 277 Vac
Agency Approval (for 134-1450 only) .....	UL file E 35198
Shipping Weight .....	2.0 lb. (0.9 kg)

## 134 Electric Switch Product Ordering

Description	Switch Action	Electrical Rating	Part No.
Pressure Differential, Adjustable Switch, 1.5 to 10 psi	DPST (NO)	<b>IND:</b> 12 A @ 120, 208 & 240 Vac	<b>134-1450</b>
	DPST	<b>Non-IND:</b> 12 A @ 120 to 277 Vac	<b>134-1451</b>
Fixed Differential Switch 2.0 psi	SPDT (NC)	<b>IND:</b> 16 A @ 120 Vac; 8 A @ 240 Vac <b>Non-IND:</b> (SPDT) 16 A @ 120 to 277 Vac (SPST) 24 A @ 120 to 277 Vac	<b>134-1460</b>

G-14

Switches & Relays

## Dimensions

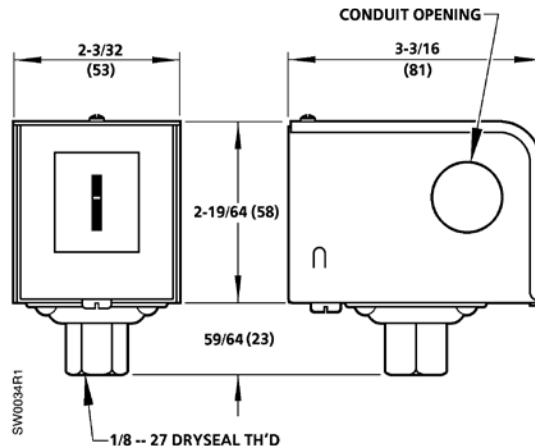

Dimensions shown in inches (mm).

## Three-way EP Valves



265-1001 Three-way EP Valve-Junction Box Type.



265-1007 Three-way EP Valve-Open Frame Type.

### Description

A general purpose, electrically operated, two-position three-way valve designed to control air flow, the 265 Three-Way Valve can be used for interlock between an electrical system and a pneumatic control system; available in open frame (yoke) and junction box (splice box) types.

### Features

- UL and CSA approved for general purpose
- Valve may be mounted in any position
- Universal replacement for many competitive models
- Mounting holes provided in the yoke
- Wide selection of AC voltages

### Applications

The 265 EP Three-way Valves are commonly-used to alternately apply pressure to and exhaust pressure from pneumatically-controlled devices, such as valves and damper actuators, by an electrical input energizing or de-energizing the solenoid of the valve.

A standard method is shown in the Application Drawings below. The input air is connected to port 1 (normally closed) and the output is connected to port 3 (common). Thus when the solenoid is energized, port 1 connects to port 3 permitting the thermostat to control the damper actuator. When the solenoid is de-energized, port 2 (normally open) is connected to port 3, exhausting air from the actuator permitting it to return to its normal position.

### Application Drawings

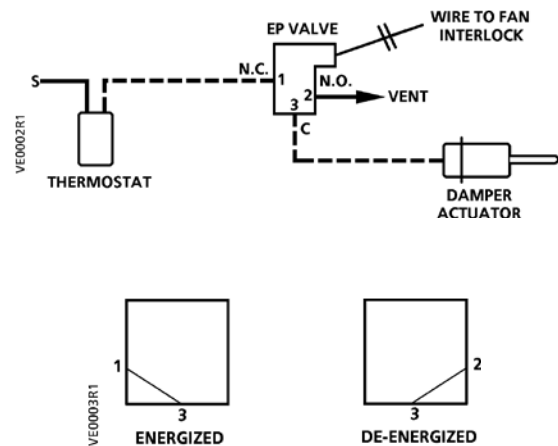

# 265 EP Valves Specifications

**Ambient Temperature**  
 Junction Box Type ..... 0 to 100°F (0 to 38°C)  
 Open Frame Type ..... 0 to 110°F (0 to 43°C)

**Controlled Medium** ..... Air only

**Maximum Air Pressure** ..... 30 psi (207 kPa)

**Air Flow Capacity**  
 Inlet Pressure ..... 20 psi (138 kPa)  
 Differential Pressure ..... 1 psi (7 kPa)  
 Air Flow ..... 600 scim (164 cm³/s)

**Cv Flow Factor** ..... 0.06

**Electrical Ratings**  
 Voltages ..... 24 to 480 Vac  
 Power Consumption ..... 5.7 Watts  
 Current Drain  
 Inrush ..... 17.3 VA  
 Holding ..... 9.2 VA

**Mounting Bracket** ..... 1 oval and open-ended hole; part of the yoke.

**Junction Box** ..... NEMA 1 Enclosure

**Air Connections** ..... Barbed fittings for 1/4" (6 mm) OD tubing

**Materials**  
 Body ..... Celcon Plastic  
 Internal ..... Buna N, Copper, Stainless Steel

**Shipping Weight**  
 Open Frame Type ..... 0.37 lb. (0.17 kg)  
 Junction Box Type ..... 0.54 lb. (0.24 kg)

## 265 EP Valves Product Ordering

AC Voltage		Part No.
60 Hz	50 Hz	
<b>Junction Box</b>		
24	—	<b>265-1001</b>
120	110	<b>265-1002</b>
208	—	<b>265-1003</b>
240	220	<b>265-1004</b>
277	—	<b>265-1005</b>
480	440	<b>265-1006</b>
<b>Open Frame</b>		
24	—	<b>265-1007</b>
120	110	<b>265-1008</b>



G-16

Switches & Relays

### Accessories & Service Kits

G-39

## Dimensions

265-1001 to 1006  
Junction Box Type

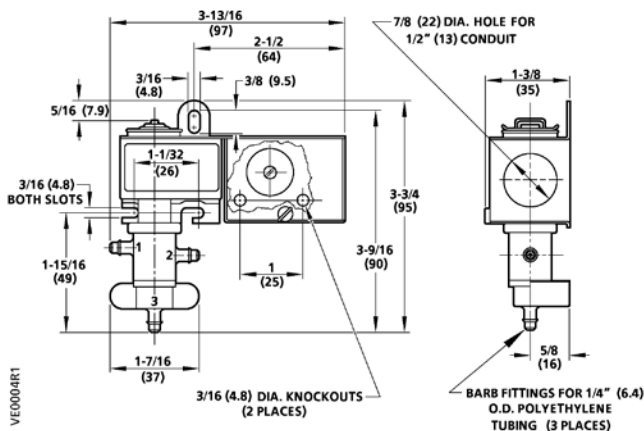

265-1007 to 1008  
Open Frame Type

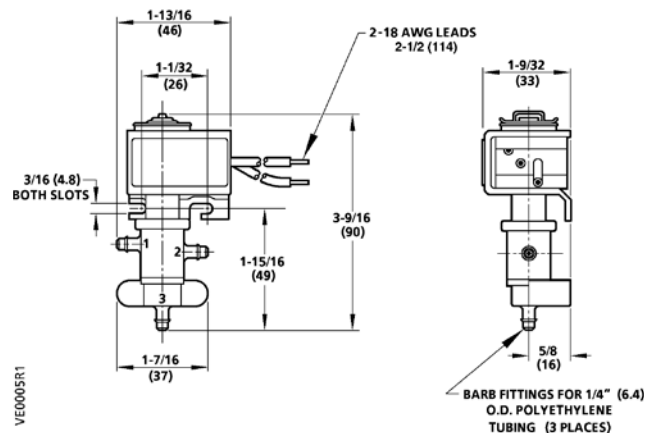

Dimensions shown in inches (mm).



Part No. in black box Ships same day when requested through Rapid Response™ shipping. See inside back cover for details.

**SIEMENS**



## Multi-purpose Relay



243-0009  
Multi-purpose Relay.

### Description

The 243 Multi-purpose Relay is pneumatic auxiliary devices designed to provide a variety of pneumatic control functions for the typical control system.

### Features

- Use for your most common applications
- High accuracy/repeatability
- Two-valve design prevents constant air loss
- Internal relief mechanism for fail safe operation

### Applications

The 243 Multi-purpose Relay is used as direct and reverse acting, amplifying, signal advancing, minimum pressure relay, and lower pressure transfer.

#### Typical Connections

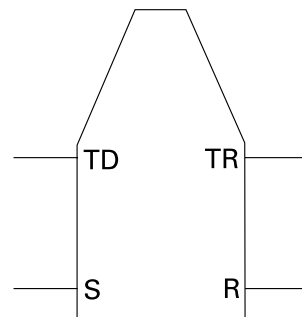

- R = output
- TD = direct acting input
- TR = reverse acting input
- S = air supply

For more detailed information on applications, refer to page I-19 in the Engineering section.



G-17

Switches & Relays

## 243 Relay Specifications

### Ambient Temperature Range

Operational..... 40 to 120°F (4 to 49°C)  
 Storage..... -20 to +120°F (-29 to +49°C)

Hysteresis ..... 0.25 psi (1.7 kPa)

Relief Valve Differential ..... 1.0 psi (6.9 kPa)

Air Capacity ..... 400 scim (109 ml/s)

Air Consumption (max.) ..... 7 scim (2 ml/s)

Spring Range ..... 0 to 25 psi (0 to 172 kPa)

Air Connections ..... 1/8" NPT

Spring Adjustment Range ..... 25 psi (0 to 172 kPa)

### Supply Air

Normal..... 25 psi (172 kPa)

Maximum..... 30 psi (207 kPa)

Shipping Weight ..... 1.5 lb. (1.35 kg)

## 243 Relay Product Ordering

Description	Part No.
Multipurpose Relay	243-0009

## Dimensions

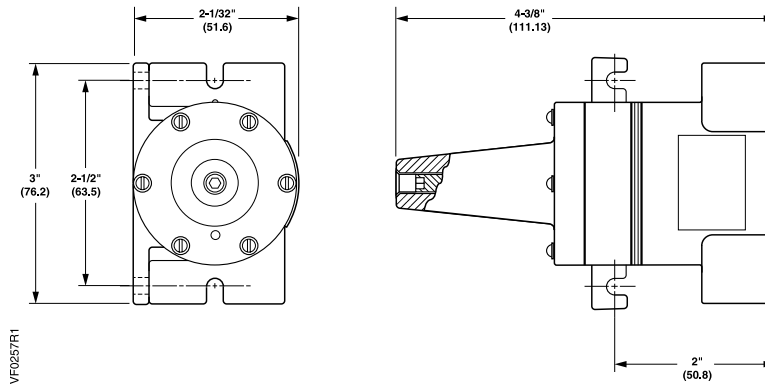

Dimensions shown in inches (mm).

## Balance-retard Relay



243-0010  
Balance-retard Relay.

### Description

The 243 Balance-retard Relay is gradual-acting, pneumatic devices designed to provide special functions such as balancing, signal retard, hesitation, and pressure limiting.

### Features

- Internal relief valve for fail-safe operation
- Adjustable retard setting

### Applications

The 243 Balance-retard Relay is adjustable and the ports can be pneumatically piped in a variety of different combinations. Each combination represents a relay application that can be used to perform a specific function in a control loop. The relay is factory set for balancing action.

#### Typical Connections

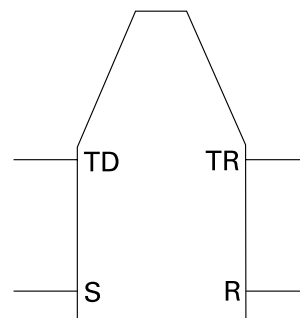

- R** = output
- TD** = direct acting input
- TR** = reverse acting input
- S** = air supply

For more detailed information on applications, refer to page I-19 in the Engineering section.



## 243 Balance-retard Specifications

### Ambient Temperature Range

Operational..... 40 to 120°F (4 to 49°C)  
 Storage..... -20 to +120°F (-29 to +49°C)

Hysteresis ..... 0.25 psi (1.7 kPa)

Relief Valve Differential ..... 1.0 psi (6.9 kPa)

Air Capacity ..... 400 scim (109 ml/s)

Air Consumption (max.) ..... 7 scim (2 ml/s)

Spring Range ..... 0 to 25 psi (0 to 172 kPa)

Air Connections ..... 1/8" -27 Female NPT

### Spring Adjustment Range

Balance ..... 0 to 15 psi (0 to 103 kPa)  
 Retard..... 0 to 10 psi (0 to 69 kPa)

### Supply Air

Normal..... 25 psi (172 kPa)  
 Maximum..... 30 psi (207 kPa)

Shipping Weight ..... 1.5 lb. (1.35 kg)

## 243 Balance-retard Product Ordering

Description	Part No.
Balance-retard Relay	243-0010

## Dimensions

G-20

Switches & Relays

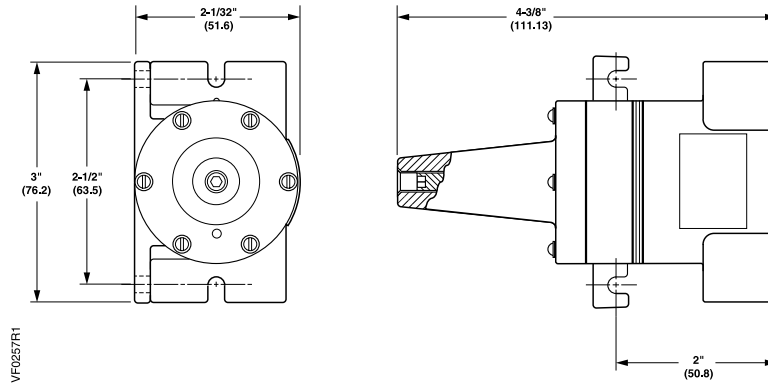

Dimensions shown in inches (mm).

## Analog Relay



243-0011 Analog Relay.

### Description

The 243 Analog Relays are pneumatic auxiliary devices designed to assist the engineer in obtaining specialized control action within a pneumatic control system.

### Features

- Multi-function
- Lightweight commercial model with molded barb fittings for 1/8" (3 mm) polyethylene tubing
- Heavy duty die-cast model with 1/8" NPT ports
- Mounting bracket included with both models; can be mounted in any position

### Applications

The 243 Analog Relay is used for amplifying, summing, differential pressure, ratio control higher pressure and signal characterization control. The relay has a two-valve design to ensure stability and prevent unnecessary air consumption.

This relay does not require any adjustment or calibration and can be mounted in any position. An internal relief is provided to assure fail-safe operation on loss of air supply.

### Typical Connections

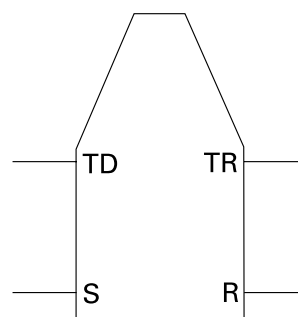

- R = output
- TD = direct acting input
- TR = reverse acting input
- S = air supply

For more detailed information on applications, refer to page I-19 in the Engineering section.



## 243 Analog Relay Specifications

### Air Supply

Normal..... 0 to 25 psi (0 to 172 kPa)  
 Maximum..... 30 psi (207 kPa)

### Ambient Temperature Range

Operating..... 40 to 120°F (4 to 49°C)  
 Storage..... -20 to +120°F (-29 to +49°C)

Hysteresis ..... 0.25 psi (1.7 kPa)

Relief Valve Differential ..... 1.0 psi (6.9 kPa)

Air Capacity ..... 400 scim (109 ml/s)

Air Consumption (max.) ..... 7 scim (2 ml/s)

Mounting ..... Integral brackets for wall or panel

Spring Adjustment Range Action ..... Gradual

### Supply Air

Normal..... 25 psi (172 kPa)  
 Maximum..... 30 psi (207 kPa)

Shipping Weight ..... 1.5 lb. (1.35 kg)

## 243 Analog Relay Product Ordering

Description	Part No.
Analog Relay	243-0011

## Dimensions

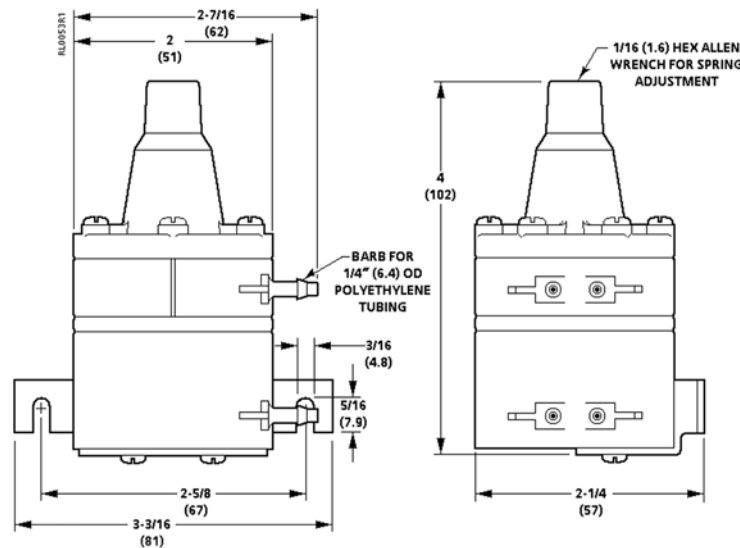

Dimensions shown in inches (mm).

# Switching Relay



243 Switching Relay.

## Description

The 243 Switching Relay is a compact three-way air valve that can be used to perform a variety of switching and diverting functions.

## Features

- Adjustable changeover pressure
- Factory calibrated at 9 psi (62 kPa) for most applications
- 1/8" NPT threaded ports

## Applications

The 243 Switch Relay action connects common port to either of two other ports.

G-23

Switches & Relays

### Typical Connections

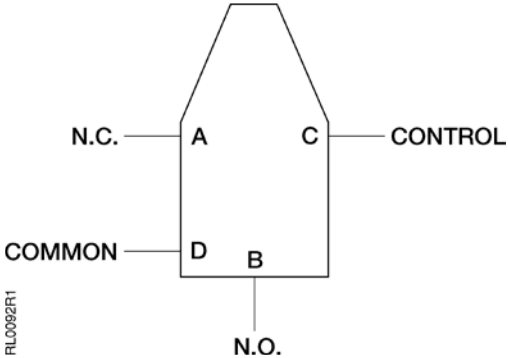

When air pressure to the C port is increased, ports A and D are connected. When air pressure to the C port is decreased, ports B and D are connected.

For more detailed information on applications, refer to page I-19 in the Engineering section.

## 243 Switching Relay Specifications

**Maximum Instrument Air Supply** ..... 30 psi (207 kPa)  
**Changeover Range** ..... 3 to 25 psi (21 to 172 kPa)  
**Standard Changeover Setting** ..... 9 psi (62 kPa)  
**Changeover Differential (nominal)** ..... 1.5 psi (10.3 kPa)  
**Ambient Temperature**  
 Maximum ..... 160°F (71.1°C)  
 Minimum ..... -20°F (-28.8°C)  
**Air Connection** ..... 1/8" NPT

**Adjustable Changeover Range** ..... 0 to 25 psi (0 to 172 kPa)  
**Changeover Differential** ..... 1.5 psi (10 kPa) nominal  
**Standard Changeover Settings** ..... 9 psi (62 kPa)  
**Nominal Capacity @ 2 psi ΔP**  
 A Port ..... 800 scim  
 B Port ..... 1100 scim  
**Shipping Weight** ..... 2.0 lb. (0.9 kg)

## 243 Switching Relay Product Ordering

Description	Part No.
Switching Relay	243-0001

## Dimensions

G-24

Switches & Relays

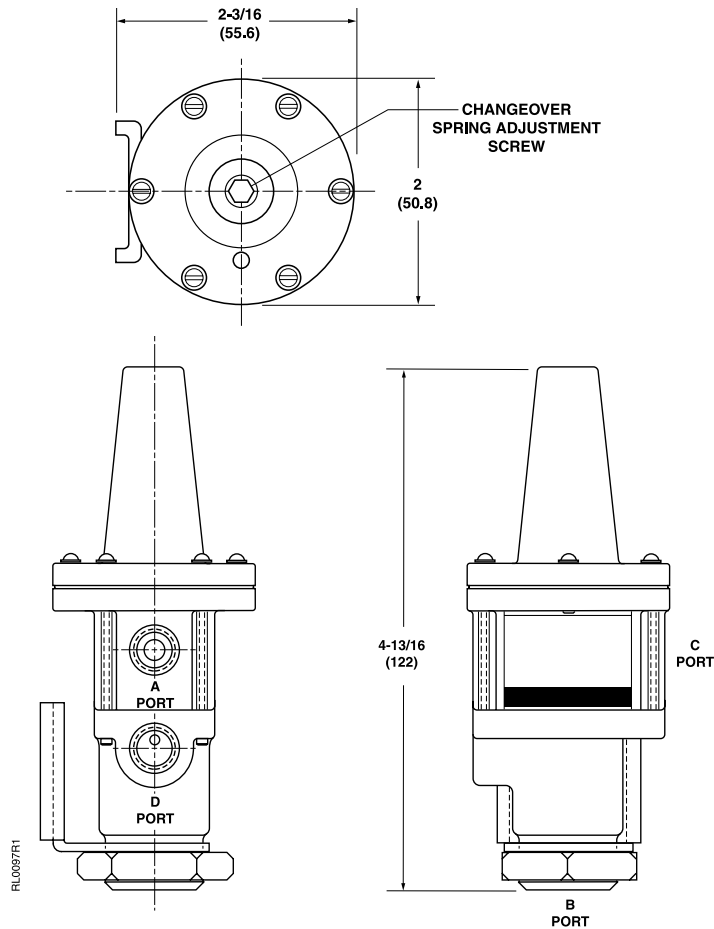

Dimensions shown in inches (mm).



## Reverse Acting Relay



243 Reverse Acting Relay.

### Description

The 243 Reverse Acting Relay provides a proportional output signal that varies inversely with the input signal. A spring adjustment is provided to allow setting a desired reverse acting schedule required by a particular application.

### Features

- Lightweight and compact
- Can be mounted in any position
- Mounting bracket and screws included
- Field adjustable spring range
- Can be used as a signal inverting relay
- Force-balance operation minimizes air consumption
- Internal relief provides fail-safe operation
- Amplifies air volume to minimize system lag

### Applications

The 243 Reverse Acting Relay has two applications. For both, the supply air pressure must be equal to or greater than the spring setting.

**Signal Reverse Acting Relay Application:** The relay reverses a controller signal to match the operation of a control element. An increase in input pressure causes equivalent decrease in output pressure.

**Signal Inverting Application:** A typical application reverses the action of a face and bypass damper actuator on a coil used for both heating and cooling. The output pressure is directly proportional to the input pressure until one-half the spring setting is reached. After this point, the output pressure is inversely proportional to the input until the output reaches zero.

G-25

Switches & Relays

### Typical Input/Output Drawings

#### Reverse Acting Relay Application

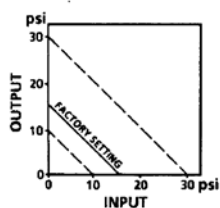

An increase in input pressure causes equivalent decrease in output pressure.

Input S1	Input B
0	15
5	10
10	5
15	0

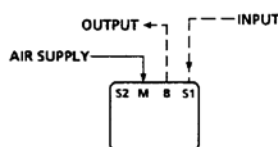

#### Signal Inverting Application

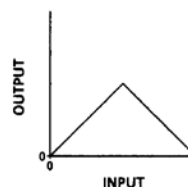

The output pressure is directly proportional to the input pressure until one-half the spring setting is reached. After this point, the output pressure is inversely proportional to the input until the output reaches zero.

Input S1+M	Output B
3	3
7.5	7.5
12	3
15	0

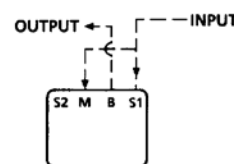

**Key**  
**B** Output Pressure      **S2** Not Used  
**M** Supply Air            **SP** Spring Setting  
**S1** Input Pressure

## 243 Reverse Acting Specifications

**Operating Range** ..... 0 to 30 psi (0 to 207 kPa)  
**Adjustment Using 5/64" (2 mm) Hex Wrench**  
 Range Adjustment ..... 10 to 30 psi (69 to 207 kPa)  
 Factory Setting ..... 15 psi (103 kPa)  
**Maximum Ambient Temperature** ..... 104°F (60°C)  
**Maximum Air Pressure** ..... 30 psi (207 kPa)  
**Air Capacity** ..... 230 scim (63 ml/s)

**Air Consumption for Air Compressor Sizing** ..... 29 scim (8 ml/s)  
**Material**  
 Housing ..... Glass-filled Nylon  
**Air Connections** ..... Barbed nipple for 1/4" (6 mm) OD polyethylene tubing  
**Mounting** ..... Mounting bracket included  
**Shipping Weight** ..... 0.27 lb. (0.13 kg)

## 243 Reverse Acting Product Ordering

Description	Part No.
Reverse Acting Relay	243-0024

## Dimensions

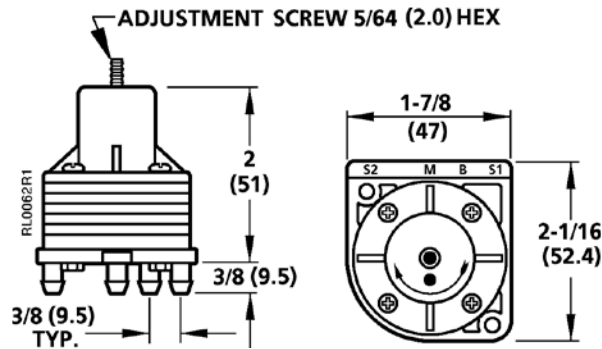

Dimensions shown in inches (mm).

# Highest Pressure Signal Selector

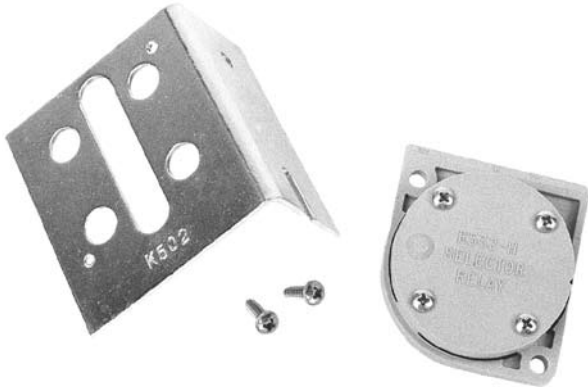

243 Highest Pressure Signal Selector and Mounting Bracket.

## Description

A dual input, single output logic device, the 243 Highest Pressure Signal Selector, is used in pneumatic control systems to compare pressure signals.

## Features

- Selects the highest of two input signals
- Small, lightweight
- Mounting bracket provided

## Applications

The 243 Highest Pressure Signal Selector is used where two proportional high capacity air signals (2-pipe thermostat) must be compared and the highest of the two signals transmitted to another logic or final control device.

## Recommendation

Use 243-0019 selector to compare more than two inputs.

### Typical Connections

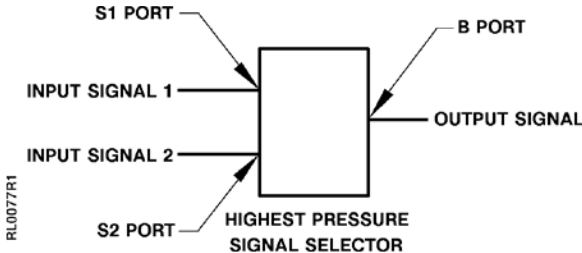

Input Signal 2	Input Signal 1	Output Signal
3 psi	15 psi	15 psi
15 psi	3 psi	15 psi
9 psi	9 psi	9 psi

G-27

Switches & Relays

## 243 Signal Selector Specifications

Action ..... Direct  
 Maximum Air Pressure ..... 30 psi (207 kPa)  
 Adjustments ..... None  
 Connections ..... 1/4" (6 mm) OD polyethylene tubing

**Operating Ambient Temperature**  
 Minimum ..... 40°F (4°C)  
 Maximum ..... 140°F (60°C)  
**Air Consumption** ..... None  
**Air Capacity @ P = 2 psi** ..... 130 scim (35 ml/s)  
**Materials** ..... Glass-filled Nylon  
**Shipping Weight** ..... 0.25 lb. (0.10 kg)

## 243 Signal Selector Product Ordering

Description	Part No.
Highest Pressure Signal Selector	243-0018
If inoperative, replace the unit.	

## Dimensions and Engineering Drawings

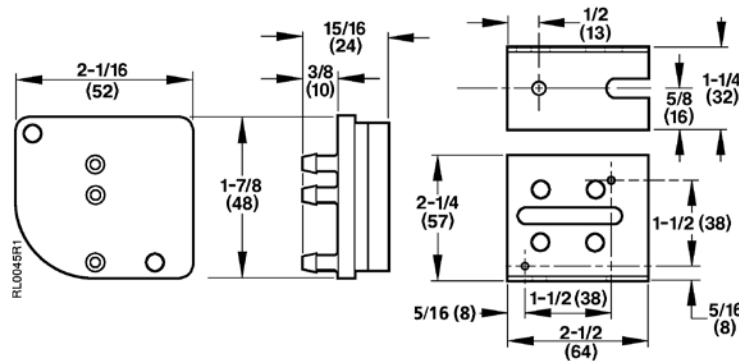

Dimensions shown in inches (mm).

### Highest of the Three Signal Pressures.

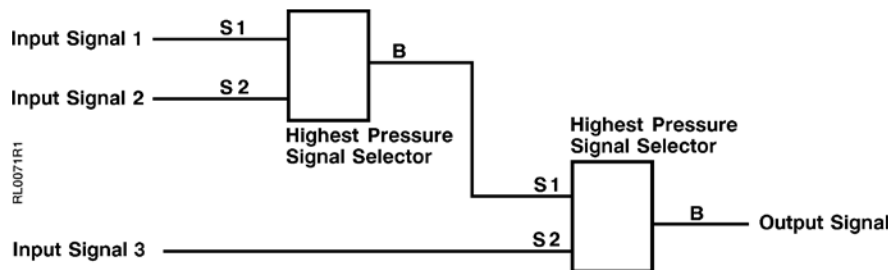

### Single Fan Cooling Control from Two Zone Direct Acting Thermostats.

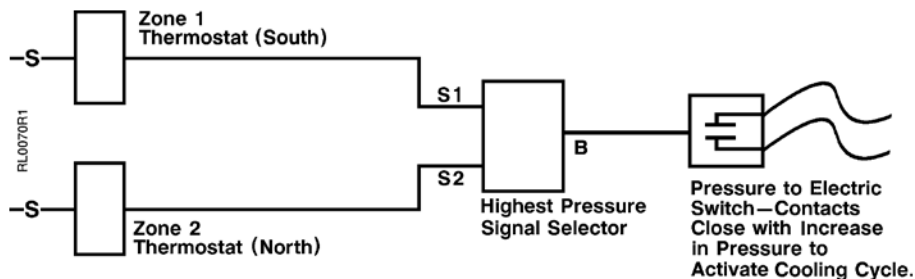

# Lowest and Highest Signal Selector

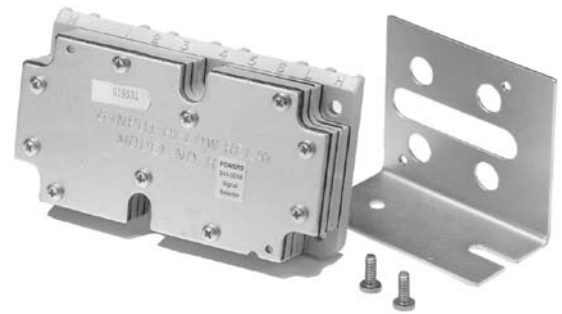

243 Lowest and Highest Pressure Signal Selector and mounting bracket.

## Description

The 243 Lowest and Highest Signal Selector is a six-input, dual output logic device for use in pneumatic control systems.

## Features

- Accepts up to 6 inputs
- Selects both or highest/lowest signal
- Easily supported in-line or mounted using provided hardware
- Small, lightweight

## Applications

The 243 Lowest and Highest Signal Selector is used where up to six input air signals must be compared and the lowest and/or highest of the signals transmitted to another logic or final control device. Unused input ports must be connected to the highest numbered input port being used. This is a low capacity output device, therefore, an amplifying relay will be required for many applications.

G-29

Switches & Relays

### Application Drawing

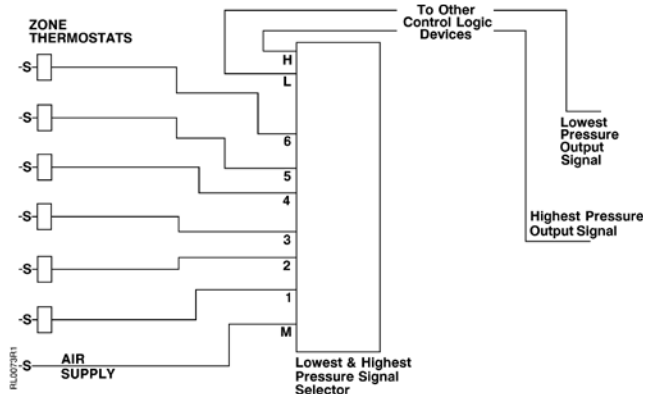

### Typical Connections

Input Port #	Input Signal	Lowest Pressure Output Signal	Highest Pressure Output Signal
1	3 psi	—	—
2	6 psi	—	—
3	9 psi	—	—
—	—	3 psi	15 psi
4	10 psi	—	—
5	13 psi	—	—
6	15 psi	—	—

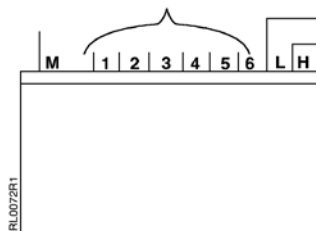

## 243 Signal Selector Specifications

**Action** ..... Direct  
**Air Supply Pressure**  
 Normal Operating ..... 20 psi (138 kPa)  
 Maximum ..... 30 psi (207 kPa)  
**Adjustments** ..... None  
**Connections** ..... 1/4" (6 mm) OD polyethylene tubing  
**Operating Ambient Temperature**  
 Minimum ..... 40°F (4°C)  
 Maximum ..... 140°F (60°C)

**Air Consumption** ..... 44 scim (12 ml/s)  
**Air Capacity @ P = 2 psi**  
 Highest ..... 5 scim (1.4 ml/s)  
 Lowest ..... 10 scim (2.7 ml/s)  
**Material** ..... Glass-filled Nylon  
**Shipping Weight** ..... 0.63 lb. (0.295 kg)

## 243 Signal Selector Product Ordering

Description	Part No.
Lowest and Highest Signal Selector	243-0019
If inoperative, replace the unit.	

## Dimensions

G-30

Switches & Relays

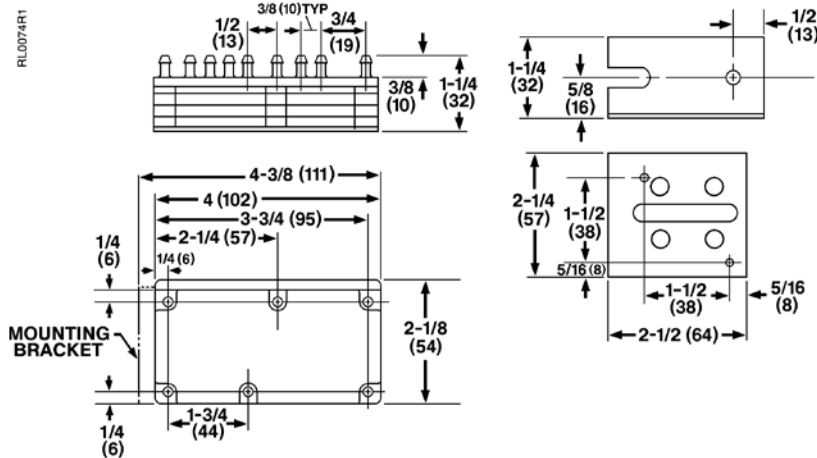

Dimensions shown in inches (mm).

# Lowest Pressure Signal Selector



243 Lowest Pressure Signal Selector.

## Description

The 243 Lowest Pressure Signal Selector is a dual input, single output logic device for use in pneumatic control systems.

## Features

- Small, lightweight
- Can be mounted in any position
- Can be supported by the 1/4-inch (6 mm) poly tubing connected to the input and output fittings
- Can be used as volume amplifying relay
- Cascade multiple selectors for more than two inputs

## Applications

The 243 Lowest Pressure Signal Selector is used where two input air signals must be compared and the lowest of the two signals transmitted to another logic or final control device. The 243 Lowest Pressure Signal Selector can also be used as a direct acting amplifying relay.

### Application Drawing

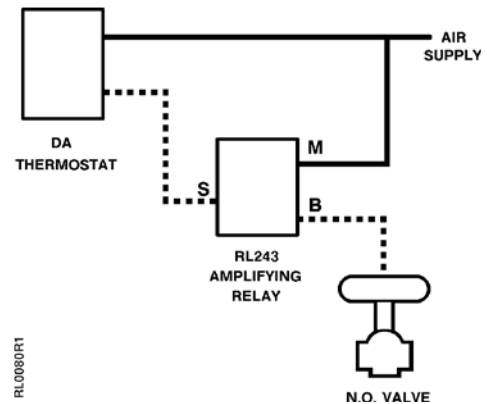

Direct Acting Amplifying Relay.

### Typical Connections

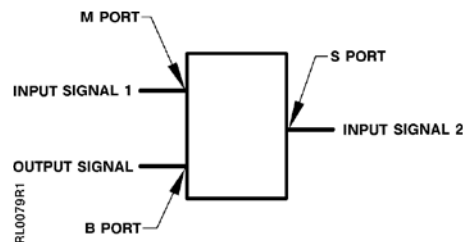

## 243 Signal Selector Specifications

**Action** ..... Direct  
**Maximum Pressure** ..... 30 psi (207 kPa)  
**Adjustments** ..... None  
**Connections** ..... 1/4" (6 mm) OD polyethylene tubing  
**Operating Ambient Temperature**  
 Minimum ..... 40°F (4°C)  
 Maximum ..... 140°F (60°C)

**Air Consumption** ..... 29 scim (8 ml/s)  
**Air Capacity @ P = 2 psi** ..... 82 scim (22 ml/s)  
**Material** ..... Glass reinforced nylon  
**Diaphragm** ..... Nylon reinforced fairprene  
**Mounting** ..... In-line  
**Shipping Weight** ..... 0.31 lb. (0.01 kg)

## 243 Signal Selector Product Ordering

Description	Part No.
Lowest Pressure Signal Selector	243-0020
<b>If inoperative, replace the unit.</b>	

## Dimensions and Engineering Drawings

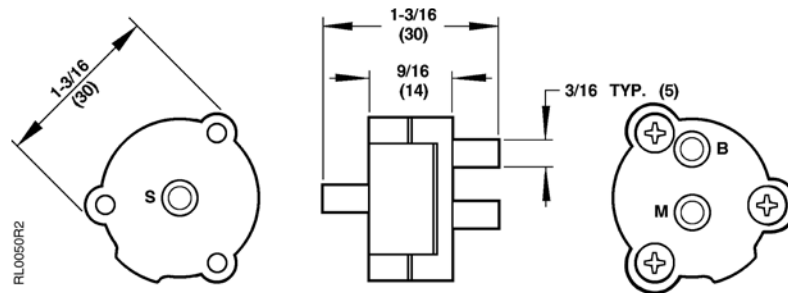

Dimensions shown in inches (mm).

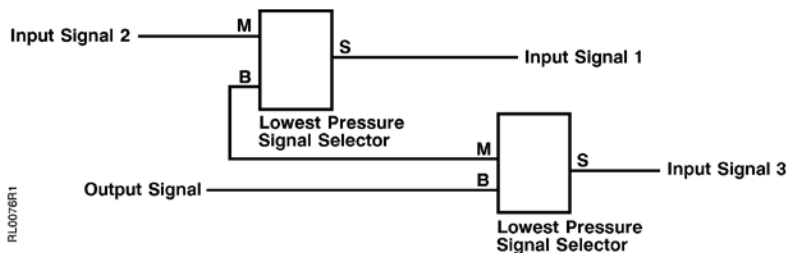

Input Signal 2	Input Signal 1	Output Signal
3 psi	15 psi	3 psi
15 psi	3 psi	3 psi
9 psi	9 psi	9 psi

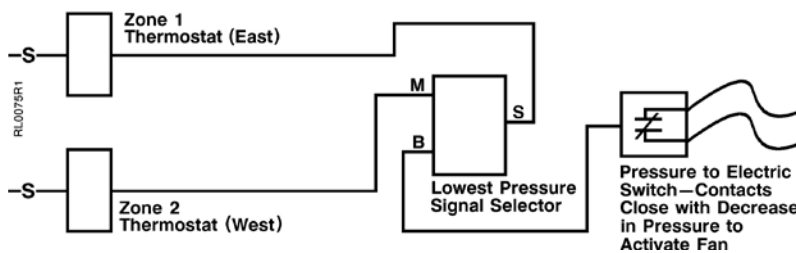

Lowest of Three Signal Pressures.



## Positioning Relay

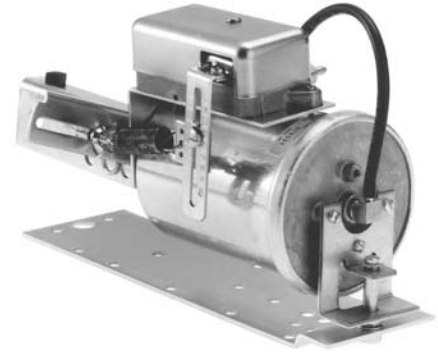

147 Positioning Relay and Mounting Kit shown on a No. 3 Damper Actuator.

### Description

The 147 Positioning Relay is a compact pneumatic auxiliary device designed to provide positive positioning of a pneumatic valve or damper actuator.

### Features

- Designed to operate at a very low bleed rate to minimize air consumption
- Provides simplified adjustment of both starting pressure and operating span
- Adjustable start point
- Adjustable span
- Rapid response
- Good repeatability
- Consistency of operation

### Applications

The 147 Positioning Relay accurately positions damper actuator in response to a control air signal change. Damper actuators that are equipped with a Positioning Relay can use full control air pressure at any point in stem travel to initiate stem movement or to maintain stem position. However, the actuator spring still provides the necessary force to move the stem in the opposite direction.

A mounting kit is required for direct attachment of the relay to a pneumatic damper actuator or valve actuator.

# 147 Positioning Relay Specifications

**Ambient Temperature Range**  
 Operating..... 35 to 160°F (2 to 71°C)  
 Storage..... -20 to +160°F (-29 to +72°C)  
**Maximum Pilot Signal Pressure** ..... 30 psi (207 kPa)  
**Maximum Supply Air Pressure** ..... 60 psi (413 kPa)  
**Start Point Adjustment Range** ..... 3 to 10 psi (21 to 69 kPa)  
**Operating Span Adjustment Range** ..... 3 to 12 psi (21 to 83 kPa)  
**Response** ..... 0.10 psi (0.689 kPa) input change

**Air Capacity @ ΔP** ..... 410 scim (112 ml/s)  
**Air Consumption** ..... 40 scim (11 ml/s)  
**Air Connections** ..... 1/8" NPT  
**Materials**  
 Body ..... Zinc  
 Cover ..... Steel  
**Shipping Weight (with mounting kit)** ..... 2.0 lb. (0.9 kg)

# 147 Positioning Relay Product Ordering

Description	Part No.	
	Positioning Relay	Mounting Kit
<b>Positioner</b>		
Field mount positioner for No. 3 Damper Actuator mfg. after 1/93	147-2000	147-104
Field mount positioner for No. 4	147-2000	147-314
Field mount positioner for No. 6	147-2000	147-276
<b>8-inch Valve Actuator</b>		
For 599 Series Flowrite actuators mfg. after 3/96	599-00426 <sup>1</sup>	
For Model 3 Flowrite actuators mfg between 3/93 and 1/96	147-2000	147-333
For Models 1 and 2 Flowrite actuators. <sup>2</sup>	147-2000	147-277
<b>12-inch Valve Actuator</b>		
For 599 Series Flowrite actuators mfg. after 1/96	599-00423 <sup>1</sup>	
For Flowrite actuators mfg. between 3/78 and 1/96	147-2000	147-311

**Ordering Note:**

1. Relay and mounting hardware included.
2. Also order spring arm, **147-307**, for use with 591 5 and 6-inch balanced valves.

# Dimensions

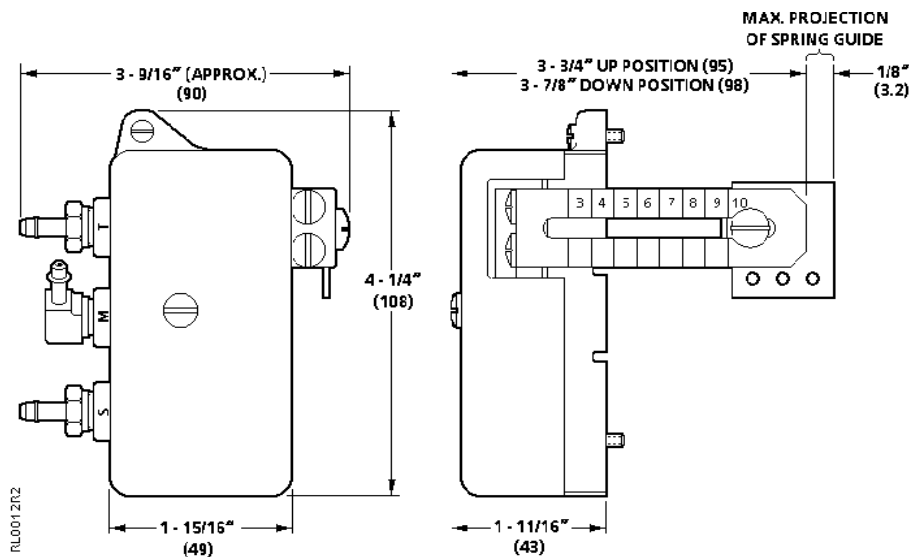

Dimensions shown in inches (mm).

## Electric-to-Pneumatic Transducer



545-208 Electronic-to-Pneumatic Transducer.

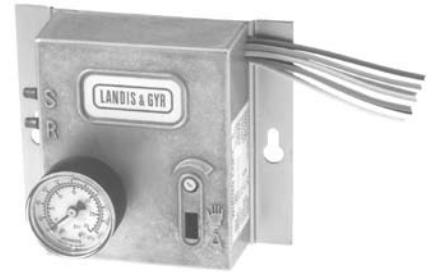

545-113 Electronic-to-Pneumatic Transducer.

### Description

The 545 Electronic-to-Pneumatic (AO-P) Transducer converts an electronic signal into a linear pneumatic signal; available in remote mount and panel mount.

### Features

- Insensitive to vibration and mounting position to allow mounting directly on equipment
- Hand-Auto switch and override dial allow for manual control of output pressure for troubleshooting and emergencies
- Accurate and repeatable output pressure signal
- Easy-to-install, no setup or calibration is required
- Wall-mount without an additional enclosure to reduce cost
- Factory-installed 0 to 30 psi (0 to 207 kPa) gauge included
- High capacity, non-bleed device

### Options

- Electrical connections to remotely monitor Hand-Auto switch position and output pressure

### Applications

The 545 Electronic-to-Pneumatic Transducers are used for accurate positioning of valve and damper actuators.

G-35

Switches & Relays

# 545 Transducer Specifications

**Supply Voltage** ..... 19 to 26 Vac (24 Vac typical)  
**Power Consumption** ..... 1 VA max.  
**Input Signal/Impedance** ..... 0 to 10 Vdc/20 K Ohm  
**Output Signal** ..... 0 to 20 psi (0 to 138 kPa)  
**Output Capacity** ..... 500 scim (135 ml/s) min.  
   @ 5 psi (34.5 kPa) Drop  
   (20 psi input, 15 psi output)  
**Output Repeatability** ..... 0.05 psi (0.35 kPa) max.  
   (includes hysteresis)  
**Output Fail-safe** ..... 0 psi (0 kPa) in response  
   to sustained power loss  
**Output Fail-safe  
 Exhaust Capacity** ..... 100 scim (27 ml/s)  
   @ 5 psi (34.5 kPa) drop (unpowered)  
**Air Supply Pressure** ..... 30 psi (207 kPa) max.  
   safe pressure, clean, dry,  
   (instrument quality air required)  
**Air Consumption for  
 Compressor Sizing** ..... 8 scim (2.2 ml/s)  
**Tubing Connection** ..... Two-1/4" (6 mm) OD nominal,  
   barbed fitting

**Conduit Connections** ..... Remote mount model has  
   Two - 1/2" (13 mm) conduit connections  
**Output Accuracy** ..... @ 77°F (25°C) ± 0.25 psi (1.72 kPa) max.  
   @ 32 to 122°F (0 to 50°C) ± 0.50 psi (3.45 kPa) max.  
   @ -40 to +185°F (-40 to +85°C) ± 1.0 psi (6.90 kPa) max.  
**Ambient Temperature Range**  
 Operating and Storage ..... -40 to +185°F (-40 to +85°C)  
**Operating Humidity** ..... 10% to 95% RH, non-condensing  
**Vibration** ..... Tested to EIA STD, RS-152B FEB 71  
**Override Controls** ..... Continuous variable output override  
   (does not function without power)  
**Override Monitoring**  
 Hand-Auto ..... A dry contact indicates the position  
   of the Hand-Auto Switch to an external device.  
**Hand-Auto Override**  
 Dry Contact Rating ..... 30 Vac @ 100 mA, 42 Vdc  
**Override Monitoring  
 Output Pressure** ..... Optional 0 to 5 Vdc linear  
   signal monitors output pressure  
**Dimensions**  
 Remote Mount ..... 4.25" H x 7.25" W x 3.06" D  
   (108 mm H x 184 mm W x 78 mm D)  
 Panel Mount ..... 4.25" H x 5.75" W x 3.06" D  
   (108 mm H x 146 mm W x 78 mm D)  
**Shipping Weight** ..... 2.0 lb. (0.9 kg)

**G-36**

**Switches & Relays**

## 545 Transducer Product Ordering

Description	Part No.
<b>Remote Mount</b>	
AO-P Transducer with Integral Enclosure	<b>545-208</b>
<b>Panel Mount</b>	
AO-P Transducer	<b>545-113</b>

## Dimensions and Engineering Drawings

**545 AO-P Transducer with Integral Enclosure**

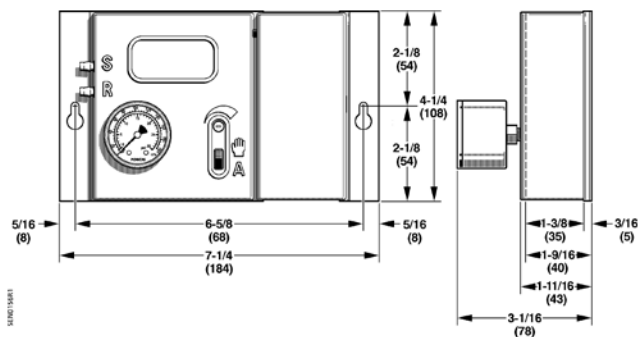

**545 AO-P Transducer**

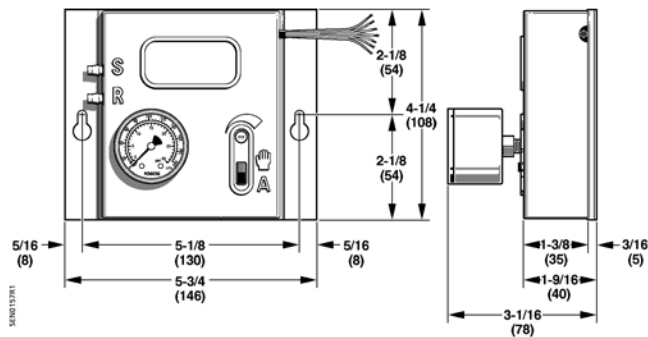

Dimensions shown in inches (mm).