

Life Is On

Schneider
Electric



Pneumatics Products Catalog

North America
EcoBuilding | 2018



www.schneider-electric.com

About Schneider Electric

Schneider Electric is leading the Digital Transformation of Energy Management and Automation in Homes, Buildings, Data Centers, Infrastructure and Industries.

With global presence in over 100 countries, Schneider is the undisputable leader in Power Management – Medium Voltage, Low Voltage and Secure Power, and in Automation Systems. We provide integrated efficiency solutions, combining energy, automation and software.

In our global Ecosystem, we collaborate with the largest Partner, Integrator and Developer Community on our Open Platform to deliver real-time control and operational efficiency.

We believe that great people and partners make Schneider a great company and that our commitment to Innovation, Diversity and Sustainability ensures that Life Is On everywhere, for everyone and at every moment.

www.schneider-electric.com

Life Is On

Schneider
Electric

Discover Life is On

Discover EcoStruxure



About This Catalog and Online Resources

Welcome to the 2018 Schneider Electric Pneumatic Products Catalog

Superior engineering, product design patents, ISO9001 certification, and Six Sigma lean manufacturing ensure our products conform to the highest standards of internationally recognized quality to deliver solid performance, unsurpassed value and exceptional reliability.

It is recommended to view this catalog in its electronic PDF version (Acrobat Reader required), from the **Exchange Extranet** or from **iPortal**.

The Exchange Extranet and iPortal

Schneider Electric's **iPortal** enables customers to quickly and easily search and order products, track order status, review order history and download product documentation.

iPortal is an important on-line tool and part of our commitment to provide comprehensive information for both internal and sales channels. Visit iPortal at this link:

[iPortal](#)

Explore the **Exchange Extranet** for quick and easy access to assets; from software and firmware to technical documentation, as well as sales and marketing collateral. Visit the **Exchange Extranet** at this link:

[Exchange Extranet](#)

About this Catalog and Online Resources

Online Selection Tool for Schneider Electric Valves/Assemblies & Damper Actuators

[Product Selection Tool](#)

In 2017 Schneider Electric launched an online selection tool for Valves/Assemblies and Damper Actuators. This tool quickly and easily puts a wealth of information at the user's fingertips to ensure specification of the optimum Schneider Electric part to fit their application.

Features

- Part selection based on calculators and drop down menus
- Save and load customer profiles, including customer name, country, contact information, job titles, project names and customer logos.
- Schedule hydronic systems using the Valve Assembly selection feature
- Schedule damper applications using the Damper Actuator selection feature
- View, edit, change and adjust schedules on the Schedule page. Download completed schedules to Excel, pdf, BOM for easy upload to iPortal, or formatted for upload to Schneider Electric's Studio 360 suite.
- Save schedules in progress to be worked on later or for use as a template for future projects.

Browser Compatibility

- Chrome (preferred), Firefox, Safari, Edge, Internet Explorer 11 or greater.

Original Valve Selection Tool

- The new online Valve Selection Tool has all the features of the original Valve Selection Tool plus added features.
- The current version of the Tool, V4.3.90 and all earlier versions will not be updated.

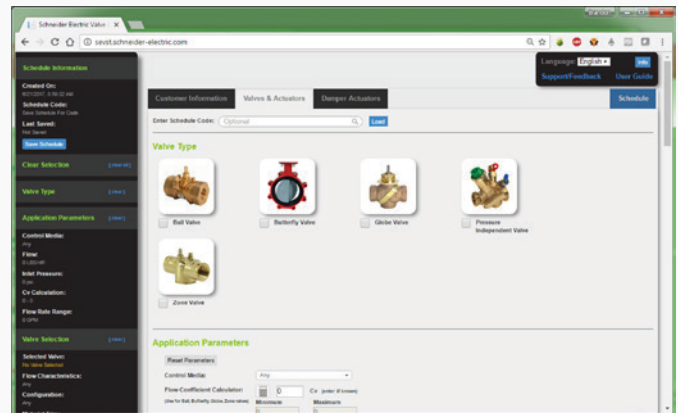

Selection Tool Product Categories

- Ball Valves
- Butterfly Valves
- Damper Actuators
- Globe Valves
- Pressure Independent Balancing Control Valves
- Zone Valves

Key Functions & Benefits

- Web-based Selection Tool (compatible with wide screen mobile devices)
- Schedule generation
- Sizing and Cv calculator
- List pricing on all products
- Schedule customization
- Quick access to related product documentation
- Favorite Products List Save Feature
- Schedule download to Excel, PDF, BOM
- Easy iPortal upload, Studio 360 File
- User Preferences and Customization
 - Company Information
 - Address & Logo
 - Favorite Parts List

MyExchange Sales Mobile App

Bring more “wow” to your customer meetings! MyExchange mobile app enables sales teams to share the latest marketing and sales content via their iOS or Android tablet or mobile phone – on- or off-line – to make meetings and follow up more productive.

With the MyExchange app you can:

- Easily access and view the latest assets (e.g. videos, presentations, specification sheets) while online
- Download assets for availability while offline
- Electronically mark up assets (highlight, pen) and save changes
- Manage a personal “channel” with your own presentation content
- Email assets to others (customers, consultants) and manage sharing activities/history
- Receive news and notifications on updates directly on your device
- To download MyExchange for iOS devices, visit the iTunes® App Store (search for “myexchange Schneider Electric”) or link to (in the U.S.):
 - MyExchange Schneider Electric on the App Store on iTunes.
 - For Android devices, access the app in the Google Play store by searching for ‘myexchange Schneider Electric’. See the Play Store for Android system requirements.

You must self-register on The Exchange before using MyExchange. Register at: <https://ecobuilding.schneider-electric.com/login-register>



Subject Index

Accessories

Actuator Shaft Extension	125
Adjustment Cover	133
Ball Joint Linkage Connector	124
Ball-joint	127
Ball-joint, swivel	127
Clevis	125
Cover Plate	130
Crank Arm	124
Damper Actuator Accessories	127
Mounting Plates	136
Pivot Stud	125
Pressure Regulator	78
Pressure Sensing Tips	146
Receiver Controller Setpoint Adjuster and Scale Plates	82
Rod End Connector	126
Slotted Crank Arm	127
Snap-in Fitting	136
Thermostat Guard	132, 133, 134
Tubing	130, 142

Actuators

Damper Actuators, Proportional	10, 12, 16
Floor Mounted Damper Actuators	14
Pneumatic Damper Actuators	2, 7
Pneumatic Valve Actuator	18
Valve Actuators, Proportional	19, 21, 23

Adaptors

Adaptor Plate	135
Brass Adaptor for T150 Immersion Transmitter	144
Gauge Adaptor	139
Neck Extension Adaptor	144

Bulb Wells

Copper Well	143, 144
Immersion Well	145
Stainless Steel Well	144

Controllers

Airstream Temperature Controllers	120
Receiver Controller	42
Single/Dual Transmitter Input Receiver Controllers	45
Unit Temperature Controllers	121

Enclosures

Control Cabinets	38
------------------------	----

Gauges

Pressure Gauges	39
Receiver Gauges	40

Kits

Brace Kit	126
Calibration Kit	140
Lock Cover Screw Kit	133
Stop Kit	135
Thermostat Conversion Kit	137

Mounting

Duct Mounting Kit	145
Frame Mounting Kit	125
Liquid Line or Tank Mounting Kit	145
Mounting Base Dual	138
Mounting Base Single	138
Mounting Plate	126, 136
Mounting Ring	135

Relay

Averaging Relay	64
-----------------------	----

Relays

2 to 1 Ratio Amplifying Relay	66
Air Motion Relay	62
Booster Relay	55
Diverting Relays	47, 49
Electric-Pneumatic Relays	53
High Pressure Selector Relay	55
Limiting, 1 to 1 Ratio Relay and Scale Plates	70
Low Pressure Selector Relay	55
Multi-Input High and Low Selector Relay	60
Positive Positioning Relay	25, 27
Reversing Relay	51
Signal Repeating Relay	68
Volume Booster/Pressure Selector Relays	57

Subject Index

Restrictors

In-line Restrictor	143
Restrictor	142
Restrictor Tee	142, 143

Solenoid Air Valves

Air Switching Valve	32
Solenoid Air Valve	30, 34, 36

Switches

Air Differential Pressure Switch	79
Gradual Switches	74
Pneumatic to Electric Pressure Switches, Two-Position ...	81
Pneumatic-Electric Switches	72
Two-, Three-, Four-Position Selector Switches	76

Thermostats

Dual Setpoint, Single Output Room Thermostats	96
Dual Setpoint/Deadband Room Thermostat	89
Energy Conservation Summer-Winter Room Thermostat .	91
Relay Bulb Thermostats	101
Room Thermostats	84
Single Setpoint Room Thermostats	93
Unitary Bulb Thermostats	99

Tools

Adaptor for Test Gauge	140
Branch Test Adaptor	140
Calibration and Cover-screw Wrench	139
Needle and Adaptor	140
Pneumatic Calibration Tool Kit	141
Pneumatic Thermostat Calibration Kit	141
Pocket Wrench	140

Transmitters

Differential or Static Pressure Transmitters	111
Differential Pressure Transmitter	109
Duct Relative Humidity Transmitter	104
Duct, Immersion and Outdoor-Air Temperature Transmitters	115
Pressure Transmitters	108
Room and Light Troffer Temperature Transmitters	117
Room Temperature Transmitter	113
Room/Duct Humidity Transmitters	106

Model Number Index

Model	Page	Model	Page	Model	Page
Numerics		22-139	130	2368-501	53
100-17	143	22-140	130	2368-502	53
100-25	144	2214-121	85	2368-521	53
100-47	144	2214-122	85	2368-522	53
100-49	144	22-143	130	2372-351	55
100-71	144	22-144	130	2372-352	55
10-11	142	2216-126	85	2372-501	57
10-51	139	2218-132	85	2372-502	57
10-53	132	2218-133	85	2373-501	60
10-59	135	2218-134	85	2374-401	62
10-62	132	2218-301	91	2376-501	64
10-64	142	2220-053	113	2378-501	66
10-73	136	2232-150	104	2379-501	68
10-76	132	22-401	144	2390-501	74
10-77	135	2252-110	115	2390-505	74
10-80	133	2252-151	116	2390-510	74
10-82	136	2252-250	115	2390-515	78
10-82-SS	136	2252-251	115	2392-504	76
20-642	135	2252-252	115	2392-505	76
20-693	142	2252-273	116	2393-504	76
20-695 (10-15)	128	2252-501	115	2420-001	39
20-706	139	2252-502	115	2420-002	39
20-707	132	2252-510	115	2420-003	39
20-712	135	2252-610	115	2420-004	39
20-714	135	2252-635	115	2420-005	39
20-715	132	2252-655	116	2422-001	40
20-778	143	2252-662	116	2422-002	40
20-782	144	2252-701	116	2422-003	40
20-803	144	2252-702	116	2890-520	129
20-805	144	2252-703	116	6-053	128
20-881	139	2260-550	120	6-054	128
20-944	142	2260-551	120	6-055	128
21-038	142	2298-060	121	6-371	135
21-039	143	2298-061	121	6-501	128
21-069	136	2298-062	121	900-002	140, 141
21-152	129	2298-063	121	900-012	141
21-153	129, 143	2301-040	108	A	
21-473	136	2301-150	108	A201	39
21-721	129	2301-300	108	A203	39
21-806	127	2302-051	109	A204-03	39
21-807	127	2323-500	111	A204-04	39
21-876	132	2323-503	111	A205-01	39
21-964	133	2323-504	111	A251-1	40
22-022	137	2323-505	111	A252	40
2211-012	85	2323-5xx	111	A253-12	40
2211-013	85	2341-501	42	AE-630	38
22-120	129	2341-502	42	AE-630-101	38
2212-118	85	2341-521	42	AE-631	38
2212-119	85	2341-522	42	AE-631-101	38
2212-318	89	2353-501	47	AE-632	38
2212-319	89	2353-502	47	AK-42309-500	25
22-130	129	2354-501	49	AKR-40605	70
22-133	129	2354-502	49	AKS-1100	82
22-134	129	2354-503	49	AL-161-4	32
22-135	129	2354-504	49	AL-170	34
22-136	130	2360-501	51	AL-171	34
22-137	130	2364-211	72	AL-180	34
22-138	139	2364-220	72	AL-181	34

Model Number Index

Model	Page	Model	Page	Model	Page
AL-183	34	M572-2308	2	MCS-PS	129
AL-190	36	M572-2311	2	MCS-S	129
AL-191	36	M572-3308	2	MCS-SC	131
AM-125-600	124	M572-3311	2	MCS-SCREW	129
AM-543	125	M572-5308	2	MCS-S-P	129
AP-302	146	M572-5311	2	MCS-TUBE	130
AT-101	133	M572-6308	2	MK-12100	16
AT-1103	133	M572-6311	2	MK-12110	16
AT-1104	133	M572-8308	2	MK-12120	16
AT-1105	134	M572-8311	2	MK-12140	16
AT-1155	134	M573	2	MK-2690	18
AT-1163	133	M573-1108	3	MK-3101	7
AT-1165	134	M573-1111	3	MK-3111	7
AT-201	145	M573-1520	3	MK-47x1	128
AT-203	145	M573-2108	3	MK-48x1	128
AT-206	145	M573-2111	3	MK-6601	21
AT-208	145	M573-2520	3	MK-6611	21
AT-209	145	M573-3108	3	MK-6621	21
AT-504	138	M573-3111	3	MK-6801	21
AT-532-098-1-1	142	M573-3520	3	MK-6811	21
AT-532-098-1-2	143	M573-5108	3	MK-6821	21
AT-532-098-1-3	143	M573-5111	3	MK-6911	21
AT-532-111-1-01	142	M573-5520	3	MK-6921	21
AT-532-111-1-02	142	M573-6108	3	MK-7821	14
AT-532-111-1-03	142	M573-6111	3	MK-7921	14
AT-532-222-2-01	142	M573-6520	3	MK-8801	23
AT-532-222-2-02	142	M573-8108	3	MK-8811	23
AT-546	138	M573-8111	3	MK-8821	23
H		M573-8520	3	MK-88xx	23
H150-100	104	M574	2	MK-8901	23
HKS-2033	106	M574-1054	4	MK-8911	23
HKS-5033	106	M574-1208	4	MK-8921	23
M		M574-1211	4	MK-89xx	23
M503	128	M574-1520	4	MSC-GA	139
M504	128	M574-2208	4	N	
M505	128	M574-2211	4	N100-0005	143
M556	2	M574-2520	4	N100-0010	142
M556-14	4	M574-3208	4	N100-10	142
M556-51	4	M574-3211	4	N100-2366	131
M570	2	M574-3520	4	N100-2500	129
		M574-5208	4		
		M574-5211	4		
		M574-6208	4		
		M574-6211	4		
		M574-6520	4		
		M574-8208	4		
		M574-8211	4		
		M574-8520	4		
		M583	2		
		M583-0520	3		
		MCS-CP	130		
		MCS-CT	130		
		MCS-CV	130		
		MCS-EB	130		
		MCS-G	129		
		MCS-GMF	130		
		MCS-MS	129		
		MCS-PLUG	130		

Model Number Index

Model	Page	Model	Page	Model	Page
N100-2501	129, 143	R540	64	TK-1301-116	93
N100-2502	129	RKSR-4000	45	TK-1381	93
N100-5	143	S		TK-1601	93
N2-4	139	S510	74	TK-1711	96
N4-32	142	S511-10	74	TK-1717	96
N5-53	136	S511-5	74	TK-1721	96
N5-95	137	S515	78	TK-1727	96
N800-0555-Box	27	S520	76	TK-1731	96
N800-0555-P	27	S521	76	TK-1741	96
N800-0801	127	S530	76	TK-1751	96
N800-0803	127	S531	76	TK-1761	96
N800-1403	127	SYZE-13425	128	TK-2001	99
N800-1404	127	T		TK-2012	99
N800-1414	127	T12-301	85	TK-2201	99
N800-1415	127	T13-301	85	TK-3001	99
P		T150-1011	115	TK-3201	99
P301-040	108	T150-1012	115	TK-4001	99
P301-150	108	T150-1013	115	TK-4012	99
P301-300	108	T150-1021	115	TK-4212	99
P323-0025	111	T150-1022	115	TK-4212-201	99
P323-01	111	T150-1023	115	TK-5001	93
P323-03	111	T150-1031	115	TK-5001-116	93
P323-10	111	T150-1035	115	TK-5101	93
P323-101	111	T150-1041	115	TK-5101-116	93
P541	42	T150-1046	116	TK-6024	101
P541-BASE	42	T150-1054	116	TK-6124	101
P541-DA-B	42	T150-1055	116	TK-8024	101
P541-RA	42	T150-1062	116	TK-8124	101
P541-RA-B	42	T150-1073	116	TKS-5001	117
PC-110	81	T150-1082	116	TKS-6001	117
PC-151	81	T150-1083	116	TOOL-100	128
PKSR-9001	109	T18-301	85	TOOL-100-500	128, 141
PND-145-104	128	T19-301	85	TOOL-78	140
PND-145-107	128	T201-023	120	TOOL-82	140
PNV-002	128	T201-024	120	TOOL-87	140
PNV-251	128	T23-301	85	TOOL-91	140
R		T24-301	85	TOOL-95-1	141
R432-11	55	T27-301	85	TOOL-96	141
R432-2	55	T32-301	85		
R435	62	T32-321	85		
R471-1	72	T33-301	85		
R472-1	72	T34-3011	91		
R503-1	47	T35-301	89		
R503-2	47	T36-301	89		
R504-1	49	T460-301	121		
R504-2	49	T461-301	121		
R504-3	49	T462-301	121		
R504-4	49	T463-301	121		
R516	51	T53-101	113		
R527-110	53	TK-1001	93		
R527-24	53	TK-1001-116	93		
R528-110	53	TK-1001-600	93		
R528-24	53	TK-1101	93		
R532-H	57	TK-1101-116	93		
R532-L	57	TK-1101-600	93		
R533	60	TK-1201	93		
R534	68	TK-1281	93		
R539	66	TK-1301	93		

Table of Contents

Damper Actuators

M5xx Series	2
MK-44xx Series.	7
MK-3xxx, MK-4xxx Series.	10
MK-71xx, MK4-71xx Series	12
MK-7821, MK-7921.	14
MK-121xx Series.	16

Valve Actuators

MK-2690 Series	18
MK-46xx Series.	19
MK-6xxx Series.	21
MK-88xx, MK-89xx Series	23

Options

AK-42309-500.	25
N800-0555	27

All specifications are nominal and may change as design improvements are introduced. Schneider Electric shall not be liable for damages resulting from misapplication or misuse of its products.

Pneumatic Damper Actuators

These actuators are designed for use in pneumatic control systems to position air control dampers in response to signals from pneumatic controllers. The M556 is a large swivel-mounted actuator with an adjustable crank arm having a clamp to fit a 1/2 in. O.D. damper shaft.

The M5xx Series damper actuators are used in pneumatic control systems to position automatic air dampers upon receipt of an air pressure signal from a control device. These actuators are equipped with right angle brackets and are adaptable to air conditioning, multi-zone, heating, ventilating, fan coil units, unit ventilators, mixing boxes, and VAV terminal boxes. M573 and M574 are also available as post-mounted actuators.

The M583 is used in classroom type unit ventilators. Special mounting kits are available for adapting the actuator to the various makes and models of classroom type units.

Features:

- Rigid, corrosion-resistant glass-filled nylon bodies.
- M556, M573 and M574 have 303 stainless steel shafts.
- M556, M573 and M574 available with or without N800-0555-P positive positioner.
- The N800-0555-P positive positioner for M556, M573 and M574 can be purchased separately.

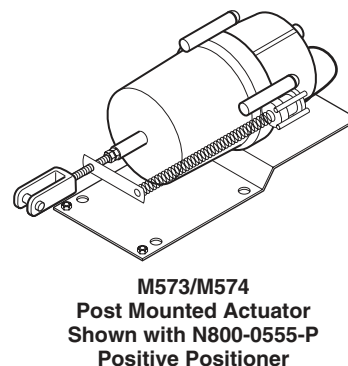
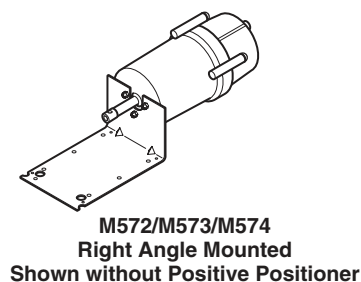
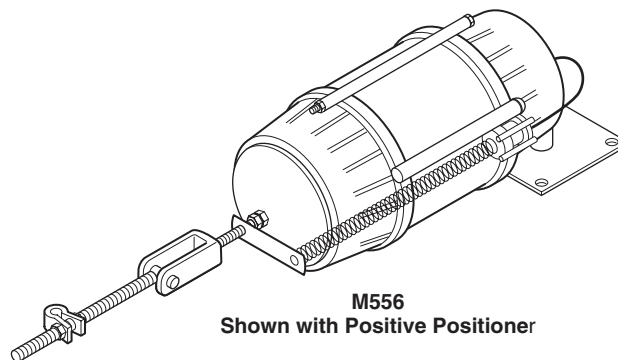

Model Chart

2 in. (51 mm) Stroke, 3 sq. in. (19.4 cm²) Effective Area.

Model No.	Spring Range		Mounting	Description
	psig	kPa		
M572-2308	3 to 12	21 to 83	Right-angle	Actuator with ball joint to accept 5/16 in. push rod.
M572-2311				Actuator with complete linkage for 1/2 in. damper shafts.
M572-8308	4 to 8	28 to 55		Actuator with ball joint to accept 5/16 in. push rod.
M572-8311				Actuator with complete linkage for 1/2 in. damper shafts.
M572-3308	5 to 10	35 to 69		Actuator with ball joint to accept 5/16 in. push rod.
M572-3311				Actuator with complete linkage for 1/2 in. damper shafts.
M572-5308	8 to 13	55 to 90		Actuator with ball joint to accept 5/16 in. push rod.
M572-5311				Actuator with complete linkage for 1/2 in. damper shafts.
M572-6308	10 to 15	69 to 104		Actuator with ball joint to accept 5/16 in. push rod.
M572-6311				Actuator with complete linkage for 1/2 in. damper shafts.

M556 Series, M572 Series, M573 Series, M574 Series, M583 Series

Hesitation Actuator.

Model No. ^a	Stroke	Diaphragm Area	Spring Range		Mounting	Description
			psig	kPa		
M583-0520	2 in. (51 mm)	7 sq. in. (45 cm ²)	1 to 4 and 8 to 12	7 to 28 and 55 to 83	Post-mtd.	Actuator with stamped clevis, clevis pin and bracket; for use on air handlers where factory mounting has not been established.

^a Total stroke of these hesitation actuators takes place in two stages, from 1 to 4 psig (7 to 28 kPa) and 8 to 12 psig (55 to 83 kPa) or 8 to 13 psig (55 to 90 kPa). No shaft movement from 4 to 8 psig (28 to 55 kPa).

3 in. (76 mm) Stroke, 7 sq. in. (45 cm²) Effective Area.

Model No.	Spring Range		Mounting	Description
	psig	kPa		
M573-2108	3 to 12	21 to 83	Right-angle	Actuator with ball joint to accept 5/16 in. push rod.
M573-2111			Right-angle	Actuator with complete linkage for 1/2 in. damper shafts.
M573-2520			Post-mtd.	Actuator with clevis and pin.
M573-8108	4 to 8	28 to 55	Right-angle	Actuator with ball joint to accept 5/16 in. push rod.
M573-8111			Right-angle	Actuator with complete linkage for 1/2 in. damper shafts.
M573-8520			Post-mtd.	Actuator with clevis and pin.
M573-3108	5 to 10	35 to 69	Right-angle	Actuator with ball joint to accept 5/16 in. push rod.
M573-3111			Right-angle	Actuator with complete linkage for 1/2 in. damper shafts.
M573-3520			Post-mtd.	Actuator with clevis and pin.
M573-1108	8 to 13	55 to 90	Right-angle	Actuator with ball joint to accept 5/16 in. push rod.
M573-1111			Right-angle	Actuator with complete linkage for 1/2 in. damper shafts.
M573-1520			Post-mtd.	Actuator with clevis and pin.
M573-5108			Right-angle	Actuator with ball joint to accept 5/16 in. push rod.
M573-5111			Right-angle	Actuator with complete linkage for 1/2 in. damper shafts.
M573-5520			Post-mtd.	Actuator with clevis and pin.
M573-6108	10 to 15	69 to 104	Right-angle	Actuator with ball joint to accept 5/16 in. push rod.
M573-6111			Right-angle	Actuator with complete linkage for 1/2 in. damper shafts.
M573-6520			Post-mtd.	Actuator with clevis and pin.

M556 Series, M572 Series, M573 Series, M574 Series, M583 Series

4 in. (mm) Stroke, 11 sq. in. (71 cm²) Effective Area.

Model No.	Spring Range		Mounting	Description
	psig	kPa		
M574-2208	3 to 12	21 to 83	Right-angle	Actuator with ball joint to accept 5/16 in. push rod.
M574-2211				Actuator with complete linkage for 1/2 in. damper shafts.
M574-2520			4 to 8	28 to 55
M574-8208	Right-angle	Actuator with ball joint to accept 5/16 in. push rod.		
M574-8211		Actuator with 1/2 in. shaft linkage and bracket.		
M574-8520	5 to 10	35 to 69	Post-mtd.	Actuator with clevis and pin.
M574-3208			Right-angle	Actuator with ball joint to accept 5/16 in. push rod.
M574-3211				Actuator with complete linkage for 1/2 in. damper shafts.
M574-3520	8 to 13	55 to 90	Post-mtd.	Actuator with clevis and pin.
M574-1054				Actuator for Keystone butterfly valve, w/positioner.
M574-1208			Right-angle	Actuator with ball joint to accept 5/16 in. push rod.
M574-1211				Actuator with complete linkage for 1/2 in. damper shafts.
M574-1520			Post-mtd.	Actuator with clevis and pin.
M574-5208			Right-angle	Actuator with ball joint to accept 5/16 in. push rod.
M574-5211				Actuator with 1/2 in. shaft linkage and bracket.
M574-6208			Right-angle	Actuator with ball joint to accept 5/16 in. push rod.
M574-6211			Right-angle	Actuator with complete linkage for 1/2 in. damper shafts.
M574-6520			10 to 15	69 to 104

6 in. (mm) Stroke, 24.8 sq. in. (160 cm²) Effective Area.

Model No.	Spring Range		Mounting	Description
	psig	kPa		
M556-14	8 to 13	55 to 90	Swivel-mtd.	60° to 120° adj. linkage to accept 1/2 in. shafts w/positioner (with 5 psi span feedback spring).
M556-51				60° to 120° adjustable linkage to accept 1/2 in. shafts.

M556 Series, M572 Series, M573 Series, M574 Series, M583 Series

Specifications

Construction	
Housing	Glass-filled nylon.
Diaphragm	Neoprene, rolling type.
Shaft	Stainless Steel on M556, M573, M574. Nickel plated steel on M572, M583.
Stroke	Refer to Model Chart.
Spring	Retract actuator shaft on loss of air pressure.
Ambient temperature limits	-20 to 180°F (-29 to 82°C).
Supply air pressure	Clean, dry, oil free air required (refer to EN-123).
Nominal	20 psig (138 kPa). [M58x Series nominal 0 to 15 psig (0 to 104 kPa).]
Maximum	30 psig (207 kPa).
Air consumption (positioner models)	0.017 scfm (0.481 L/m).
Adjustments	
Hesitation stroke start point	4 psig (28 kPa); stroke adjustable 20% to 70% prior to 4 psig (M583 only).
Finish stroke start point	8 psig (55 kPa); stroke adjustable 80% to 30% after 8 psig (M583 only).
Connections	Barbed fitting for 1/4 in. O.D. plastic tubing.
Dimensions	
M556 Series	5-3/4 dia. x 17 L in. (146 x 432 mm).
M573 Series	3-3/4 dia. x 14 L in. (95 x 356 mm).
M574 Series	4-5/8 dia. x 15-1/8 L in. (117 x 384 mm).

Part Number	Factory Installed Positive Positioner	Nominal Operating Range (psi)	Starting Pressure Adj. (psi)	Effective Area Sq. In.	Nominal Stroke from Linkage for Nominal Operating Range (Inches)	Power Factor (Area x Stroke)	Nominal Torque Proportional Control	
							15 psi Pressure to Actuator (lb. - in.)	20 psi Pressure to Actuator (lb. - in.)
M572-8308	No	4 to 8	4, Non-Adj.	3	2	6	4.50	4.50
M572-3308		5 to 10	5, Non-Adj.					
M572-5308		8 to 13	8, Non-Adj.					
M572-2308		3 to 12	3, Non-Adj.					
M573-1108	Yes	8 to 13	8, Non-Adj.	7	3	21	21.00	68.25
M573-1111								
M573-3108	No	5 to 10	5, Non-Adj.					
M573-3111								
M573-5108								
M573-5111	8 to 13	8, Non-Adj.	8, Non-Adj.	11	4	44	44.00	143.00
M574-1208								
M574-1211								
M574-3208	No	5 to 10	5, Non-Adj.	11	4	44	33.00	33.00
M574-3211								
M574-5208		8 to 13	8, Non-Adj.					
M574-5211								
M566-14	Yes			24.8	6	148.8	148.80	483.60

M556 Series, M572 Series, M573 Series, M574 Series, M583 Series

Accessories

Part Number	Description
AM-112	Slotted crank arm for 3/8 in. shaft
AM-113	Slotted crank arm for 1/2 in. shaft.
AM-115	Slotted crank arm for 7/16 in. shaft.
AM-122	Straight connector.
AM-123	Damper clip.
AM-125	5/16 x 20 in. damper rod.
AM-125-048	5/16 x 48 in. damper rod.
AM-132	Ball joint connector.
N5-75	1/2 in. I.D. shaft coupling to extend damper drive shafts (includes four set screws).
N800-1403	Slotted crank arm for 3/8 in. shaft.
N800-1404	Slotted crank arm for 1/2 in. shaft.
N800-1414	3-hole crank arm for 3/8 in. shaft (for 2, 3, 4 in. strokes).
N800-1415	3-hole crank arm for 1/2 in. shaft (for 2, 3, 4 in. strokes).
N800-0555-BOX	Pilot positioner only.
N800-0555-P	Positive positioner kit with feedback arm and springs.
Diaphragms	
N800-9422	For M572 (2472) Series.
N800-9423	For M573 (2473) Series.
N800-9424	For M574 (2474) Series.
N800-9426	For M556 (2466) Series.

Pneumatic Damper Actuators

Proportional pneumatic actuator with 8 in.² (52 cm²) effective area used to control dampers, mixing boxes, air valves, etc., in heating, ventilating, and air conditioning systems.

Features:

- Rugged cast aluminum bodies.
- Long lasting rolling diaphragm.
- Provisions for adjustable stroke-stop.

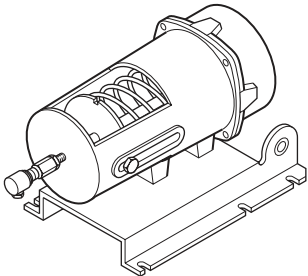

MK-31xx Series

Model Chart												
Model No.	Nominal Operating Range		Starting Pressure		Nominal Stroke ^a	Maximum Force ^b				Nominal Torque ^c Proportional Control ^b		
						Return Stroke	Power Stroke			Proportional Control ^b		
	psig	kPa	psig	kPa	in. (mm)	Based on 1.5 psi (10 kPa) Pressure to Actuator	15 psi (103 kPa) Supply Dual Press. System	15 psi (103 kPa) Supply Single Press. System ^d	20 psi (138 kPa) Supply Single or Dual Press. System ^d	15 psi (103 kPa) Supply Dual Press. System	15 psi (103 kPa) Supply Single Press. System ^d	20 psi (138 kPa) Supply Single or Dual Press. System ^d
					lb (N)	lb (N)	lb (N)	lb (N)	lb-in. (N-m)	lb-in. (N-m)	lb-in. (N-m)	
MK-3101	3 to 8	21 to 55	3 ±1	21 ±7	3-1/2 (89), adjustable	12 (53)	44 (196)	56 (249)	96 (427)	21 (2.37)	21 (2.37)	21 (2.37)

^a Factory setting required for published operating range.
^b Force and torques based on factory set stroke and starting pressure.
^c Nominal torque for actuators without positive positioner is based on 1.5 psi pressure change at the actuator.
^d Adjust pressure reducing valve so that listed pressures are available at the actuator.

This page intentionally left blank

Accessories

Part Number	Description
AK-42309-500	Positive positioner and linkage.
AM-111	Crank arm for 5/16 in. diameter damper shaft
AM-161-3	Damper linkage kit AM-113 crank arm and AM-132 connector).
AM-301	90° mounting bracket for pivot mounting.
TOOL-095-1	Pneumatic calibration tool kit.
Maintenance Parts	
PND-002-1	Diaphragm.
PND-91	High temperature diaphragm.
PND-045-343*	Green, 3 to 8 psi spring.
PND-045-345*	Black, 5 to 10 psi spring.
PND-045-348*	Blue, 8 to 13 psi spring.
PND-050-343*	White, 3 to 13 psi spring.
PND-504	Shaft connector.

*2 springs required per actuator.



This page intentionally left blank

This page intentionally left blank

This page intentionally left blank

This page intentionally left blank

Floor Mounted Damper Actuators

For proportional pneumatic actuator used to control inlet vanes on small and medium size fans or large jackshafted dampers.

Features:

- Dual actuators, operating a single shaft and piloted by a position, provide maximum capacity for heavy loads.
- Lever with multiple holes facilitates stroke adjustment to suit various applications.
- Rigid steel base provides firm actuator support.

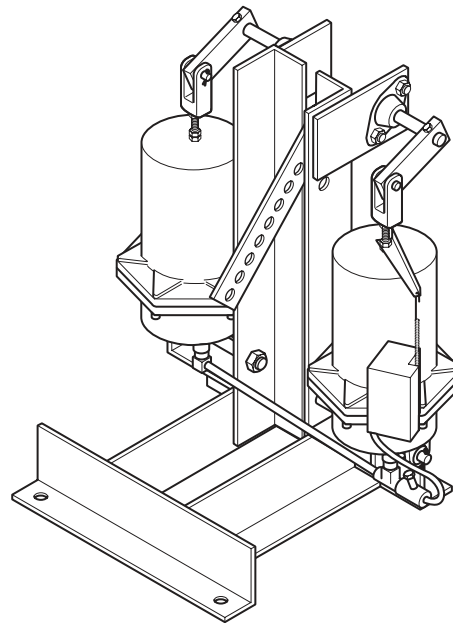

MK-7921

Model Chart														
Model No.	Diaph. Area (Total) in. ² (cm ²)	Stroke in. (mm)										Max. Torque Power Stroke lb-in. (N-m)	Return Stroke lb-in. (N-m)	Nominal Torque for Proportional Control ^a lb-in. (N-m)
		4 (102)	5 (127)	6 (152)	7 (178)	8 (203)	9 (229)	10 (254)	11 (279)	12 (305)	13 (330)			
		Lb (N) Force Available for Various Strokes ^b												
MK-7821 Single	20 (129)	135 (600)	108 (480)	90 (400)	77 (343)	68 (302)	60 (267)	54 (240)	49 (218)	45 (200)	42 (187)	315 (35.5)	360 (40.6)	67.5 (7.6)
MK-7921 Dual	40 (258)	270 (1201)	216 (961)	180 (801)	154 (685)	136 (605)	120 (534)	109 (465)	98 (436)	90 (400)	84 (374)	630 (71.0)	720 (81.2)	135 (15.2)

^a Based on a 1.5 psig (10kPa) pressure change at the actuator.

^b With 20 psig (138 kPa) main supply.

Specifications

Construction

Housing	Die cast aluminum.
Diaphragm	Replaceable beaded molded neoprene.
Assembly	Actuator(s) and positive positioner (AK-42309-500) are factory mounted on a frame of channel and angle iron.
Rotary output	Provided by a driving lever arm connected to a bearing supported jackshaft.
Stroke	Rotary output of 60° driving lever arm connecting point adjustable from 4 to 13 in. (102 to 330 mm), in 1 in. (25.4 mm) increments, from centerline of jackshaft.
Nominal damper area	Actuator sizing should be done in accordance with damper manufacturer's specifications.
Connecting linkage	AM-394 adjustable 15-3/4 to 24-3/4 in. (400 to 629 mm) is included to link actuator to damper.
Spring	Retracts actuator shaft on loss of air pressure.
Maximum air pressure	30 psig (207 kPa).
Ambient temperature limits	
Shipping	-40 to 160°F (-40 to 71°C).
Operating	-20 to 160°F (-29 to 71°C).
Air connections	Barbed fitting for 1/4 in. plastic tubing.
Mounting	Floor.
Dimensions	30-1/2 H x 16 W x 20 D in. (775 x 406 x 508 mm).

Accessories

Model No.	Description
Linkage AM-394	Actuator Linkage
Maintenance Parts PND-90	High temperature diaphragm.
PND-202	Diaphragm.
PND-245-103	2 to 8 psig spring.
PND-245-108	8 to 13 psig spring.

Damper Actuators, Proportional

For proportional pneumatic actuator with 3 in.² (19 cm²) effective area used to control small dampers and mixing boxes.

Features:

- Plastic housing.
- Meets UL-465 requirements for air plenum mounting.
- Ideal for VAV terminal unit control.

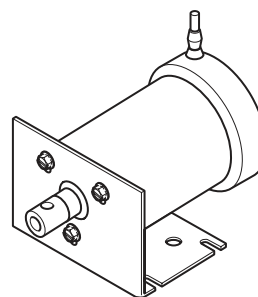

Model Chart										
Model No.	Nominal Operating Range	Stroke	Starting Pressure Non-Adjustable	Maximum Force ^a				Nominal Torque ^b Proportional Control		
				Return Stroke	Power Stroke			15 psi Supply Dual Press. System	15 psi Supply Single Press. System ^c	20 psi Supply Single or Dual Press. System ^c
				Based on 1.5 psi Pressure to Actuator	15 psi Supply Dual Press. System	15 psi Supply Single Press. System ^c	20 psi Supply Single or Dual Press. System ^c			
psi	in.	psi	lb	lb	lb	lb	lb-in.	lb-in.	lb-in.	
MK-12100	3 to 8	2	3	4.5	16.5	21	36	4.5	4.5	4.5
MK-12110	5 to 10		5	10.5	10.5	15	30			
MK-12120	8 to 13		8	19.5	1.5	6	21	1.5		
MK-12140	3 to 13		3	4.5						

^a Force and torques based on factory set stroke, starting pressure, and 90° rotation of driven damper shaft.

^b Nominal torque for actuators is based on 1.5 psi (10 kPa) pressure change at the actuator.

^c Adjust pressure reducing valve so that listed pressures are available at the actuator.

Specifications

Construction	
Housing	UL-94-5V flame rated plastic material to meet UL-465 requirements for air plenum mounting.
Diaphragm	Beaded molded neoprene.
Stroke	2 in. (50.8 mm).
Nominal Damper Area	Actuator sizing should be done in accordance with damper manufacturer's specifications.
Spring	Retracts actuator shaft on loss of air pressure.
Maximum air pressure	30 psig (207 kPa).
Ambient temperature limits	
Shipping	-40 to 180°F (-40 to 82°C).
Operating	-20 to 150°F (-29 to 66°C).
Air connections	Barbed for 1/4 in. O.D. plastic tubing [for runs up to 20 ft. (6 m)].
Mounting	In any position. Mounting bracket and ball joint connector for 5/16 in. diameter push rod assembled to actuator.
Dimensions	5-5/8 H x 3-9/16 W x 3-5/16 D in. (143 x 90 x 84 mm).

Accessories

Part Number	Description
AM-111	Crank arm for 5/16 in. diameter damper shaft.
AM-161-3	Damper linkage kit (AM-113 crank arm and AM-132 connector).
TOOL-095-1	Pneumatic calibration tool kit.

Pneumatic Valve Actuator

For proportional pneumatic control of 1/2 in. to 2 in. VB-7xxx Series valves (subject to close-off ratings) and discontinued 1/2 in. to 1-1/4 in. VB-9xxx valves.

Features:

- Compact size with 6 in.² (39 cm²) effective area.
- Rugged die cast aluminum housing.
- Replaceable beaded molded neoprene diaphragm.

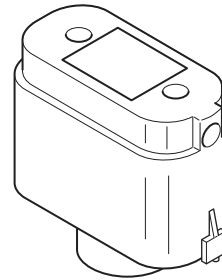

Model Chart		
Model No.	Nominal Spring Range ^a (Spring Color Code)	
	psig	kPa
MK-2690	3 to 7 (Yellow)	21 to 48
	5 to 10 (Black)	34 to 69
	8 to 13 (Blue)	55 to 90

^a Nominal (no load) condition, spring ranges based on 1/2 in. (13 mm) maximum stroke, provided by AV-7400 or AV-400 linkage (order separately).

Specifications	
Inputs Compatible with	Proportional pneumatic signal. Refer to Model Chart.
Start point	Non-adjustable.
Air connections	1/8 in. FNPT located on side of housing.
Mechanical Outputs	
Stroke	1/2 in. (12.6 mm) nominal.
Environment	
Ambient temperature limits	Shipping: -40 to 220°F (-40 to 104°C). Operating: -20 to 220°F (-29 to 104°C).
Humidity	5 to 95% RH, non-condensing.
Maximum air pressure	30 psig (207 kPa).
Spring	Stainless steel spring retracts actuator shaft and raises valve stem on loss of air pressure. Springs provided in AV-400 or AV-7400 linkage (order separately).
Dimensions	3-9/16 H x 5 W x 2-1/4 D in. (90 x 127 x 57 mm).

Accessories	
Model No.	Description
AK-42309-500	Positive positioner and linkage.
AV-400	Valve linkage (includes parts for VB-7xxx and discontinued 1/2 to 1-1/4 in. VB-9xxx valves).
AV-7400	Valve linkage for VB-7xxx valves only.
TOOL-095-1	Pneumatic calibration tool kit.
Maintenance Parts	
PNV-144-043	Yellow 3 to 7 psig spring.
PNV-145-045	Black 5 to 10 psig spring.
PNV-145-048	Blue 8 to 13 psig spring.
PNV-102-1	Diaphragm.
PNV-103-3	Lower housing.

This page intentionally left blank

This page intentionally left blank

Valve Actuators, Proportional

Proportional pneumatic actuator with 50 sq. in. (323 cm²) effective diaphragm area used to control
 1-1/2 in. to 2 in. VB-7xxx series,
 2-1/2 in. to 6 in. VB-8xxx series,
 2-1/2 in. to 6 in. VB-9xxx series,

Features:

- Rugged die cast aluminum construction.
- Rolling diaphragm.
- Three spring ranges for various applications.
- Start point adjustable ± 2 psi.

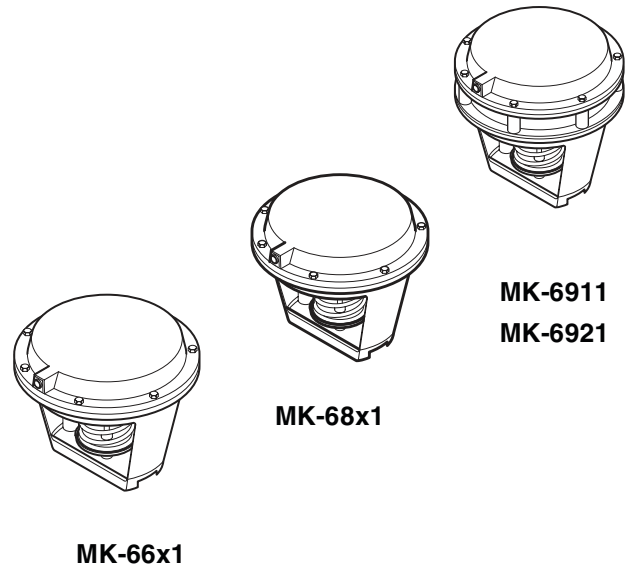

Model Chart			
Model No.	Nominal Spring Range ^a		Nominal Stroke in. (mm)
	psig	kPa	
MK-6601	3 to 8	21 to 55	1/2 (13.7)
MK-6611	5 to 10	34 to 69	1/2 (13.7)
MK-6621	8 to 13	55 to 90	1/2 (13.7)
MK-6801	3 to 8	21 to 55	1 (25.4)
MK-6811	5 to 10	34 to 69	
MK-6821	8 to 13	55 to 90	
MK-6911 ^{bc}	5 to 10	34 to 69	1-1/2 (33.1)
MK-6921 ^b	8 to 13	55 to 90	1-1/2 (33.1)

^a Nominal (no load) spring ranges based on maximum 1/2 in. (13.7 mm), 1 in. (25.4 mm) or 1-1/2 in. (33.1 mm) stroke for MK-6911.

^b MK-6911 is only used on 6 in. VB-8xx3-0-5-16. MK-6911 and MK-6921 were used on discontinued 4 to 6 in. VB-9323-0-5-x.

^c Recommended for field replacements only where 20 psi air supply pressure is not available and/or required close-off pressure is less than 125 psi.

Specifications

Construction	
Housing	Die cast aluminum.
Diaphragm	Replaceable beaded molded neoprene (Part number PNV-202).
Stroke	Refer to Model Chart.
Spring	Retracts actuator shaft and raises valve stem on loss of air pressure.
Nominal spring range	Refer to Model Chart.
Starting point	Adjustable ± 2 psig (± 14 kPa).
Maximum air pressure	30 psig (207 kPa).
Ambient temperature limits	
Shipping	-40 to 220°F (-40 to 104°C).
Operating	-20 to 220°F (-29 to 104°C).
Air connections	1/8 in. FNPT.
Valve linkage	Refer to Accessories (order separately).
Mounting	In any upright position with actuator head above the center line of the valve body.
Dimensions	7-3/4 H x 10-1/2 W x 10-1/2 D in. (199 x 267 x 267 mm).

MK-6xxx Series

Actuators

Accessories

Part Number	Description
AK-42309-500	Positive positioner and linkage.
TOOL-095-1	Pneumatic calibration tool kit.
Linkage	Valve Body Series
AV-430	VB-7xx3, 1-1/2 to 2 in.
	VB-7xx4, 1-1/2 to 2 in.
AV-495	VB-9323, 2-1/2 to 6 in. (discontinued).
	VB-9213, 2-1/2 to 4 in. (discontinued).
	VB-9223, 2-1/2 to 4 in. (discontinued).
AV-497	VB-9313, 2-1/2 to 4 in.
	VB-8213, 2-1/2 to 6 in.
	VB-8223, 2-1/2 to 6 in.
	VB-8303, 2-1/2 to 6 in.
Maintenance Parts	
PNV-202	Diaphragm.
PNV-245-013	Green, 3 to 8 psi spring.
PNV-245-015	Gray or black, 5 to 10 psi spring.
PNV-245-018	Blue, 8 to 13 psi spring.

Valve Actuators, Proportional

Proportional pneumatic actuator with 100 in.² (645 cm²) effective area. MK-88xx Series used to control 2-1/2 in. through 4 in. valves requiring 1 in. stroke. MK-89xx Series used to control 5 in. and 6 in. valves requiring 2 in. nominal stroke. Used with VB-931x, and discontinued VB-921x, and VB-922x valves.

Features:

- Heavy duty aluminum construction.
- Large diaphragm area provides the required force to modulate large valves.
- Valve stroke indicated in 1/8 in. increments.

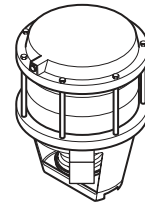

MK-88xx Series

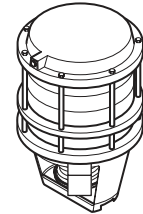

MK-89xx Series

Model Chart					
Model No.	Nominal Spring Range ^a		Nominal Stroke		For Use with Valve Bodies
	psig	kPa	in.	mm	
MK-8801	3 to 8	21 to 55	1	25.4	2-1/2 to 4 in. VB-9213 VB-9223 VB-9313
MK-8811	5 to 10	34 to 69			
MK-8821	8 to 13	55 to 90			
MK-8901	3 to 8	21 to 55	2	50.8	5 in. and 6 in. VB-9213 VB-9223 VB-9313
MK-8911	5 to 10	34 to 69			
MK-8921	8 to 13	55 to 90			

^a Nominal (no load) spring ranges are based on maximum 1 in. (25.4 mm) or 2 in. (50.8 mm) stroke.

Specifications	
Construction	
Housing	Die cast aluminum.
Diaphragm	Replaceable beaded molded neoprene.
Stroke	Refer to Model Chart.
Spring	Retracts actuator shaft and raises valve stem on loss of air pressure.
Nominal spring range	Refer to Model Chart.
Starting point	Adjustable ±1 psi (±7 kPa).
Maximum air pressure	30 psig (207 kPa).
Ambient temperature limits	
Shipping	-40 to 220°F (-40 to 104°C).
Operating	-20 to 220°F (-29 to 104°C).
Air connection	1/8 in. FNPT.
Valve linkage	Order separately AV-496.
Valve stroke position indication	1/8 in. (3 mm) increments.
Mounting	In any upright position with actuator head above 45° of the center line of the valve body.
Dimensions	
MK-88xx Series	11-3/4 H x 10-1/2 W x 10-1/2 D in. (298 x 267 x 267 mm).
MK-89xx Series	12-3/4 H x 10-1/2 W x 10-1/2 D in. (342 x 267 x 267 mm).

MK-88xx Series, MK-89xx Series

Accessories

Part Number	Description
AK-42309-500	Positive positioner with linkage.
TOOL-095-1	Pneumatic calibration tool kit.
Linkage	
AV-496	Valve linkage.
Maintenance Parts	
PNV-202	Diaphragm (2 required).
PNV-312	Rolling diaphragm.

Positive Positioning Relay

Positive positioner pneumatic relay is used to accurately position an actuator stroke with respect to signal pressure from the controller. It can also be used to change the effective spring range of an actuator and increase the capacity of a controller.

Features:

For accurate positioning of valve and damper actuators, this positioner utilizes a pilot-operated, relay-type position-sensing mechanism, much more sensitive to actuator position changes than some competitive “force-balance” positioners.

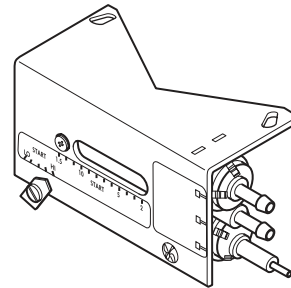

Model Chart	
Model No.	Description
AK-42309-500 ^a	Positive Positioning Relay with Mounting Linkage.

^a AK-42309-500 positive positioner cannot be used with M556, M572, M573, M574, and MK-12000 Series actuators. Use N800-0555 positioner with M556, M573, and M574.

Specifications	
Action	Direct (increase in output pressure to actuator with an increase in pilot pressure from controller).
Pilot input	0 to main air pressure, psig.
Output	0 to main air pressure, psig.
Construction	
Housing	Polysulfone.
Diaphragm	Neoprene.
Start point	Adjustable 1 to 12 psig (7 to 83 kPa).
Span	Adjustable 2 to 13 psi (14 to 90 kPa); factory set at 5 psig.
Stroke	Adjustable 2 to 13 psi (14 to 90 kPa); factory set at 5 psig with feedback spring for 7/16 to 5 in. stroke.
Supply air pressure	
Maximum	30 psig (207 kPa).
Nominal supply	15 to 20 psig (103 to 138 kPa).
Environment	
Ambient temperature limits	Shipping: -40 to 160°F (-40 to 71°C). Operating: 32 to 140°F (0 to 60°C).
Humidity	5 to 95% R.H., non-condensing.
Locations	NEMA Type 1 (IP10).
Air connection code	Refer to Figure 1.
Air connections	
“M” and “B”	Barbed for 1/4 in. O.D. plastic tubing.
“P”	Dual-contoured for 1/4 in. O.D. and 5/32 in. O.D. tubing.
Air consumption for sizing air compressor	19 scim(5.2 mL/s) at 20 psig (138 kPa) supply.
Air capacity for sizing air mains	20 scim (5.5 mL/s).
Flow capacity	860 scim (235 mL/s) at 20 psig (138 kPa) supply.
Mounting linkage	All necessary linkage provided to assemble AK-42309-500 to MK-2690 actuator and the following actuator series; MK-3000, MK-4400, MK-4600, MK-4700, MK-4800, MK-6600, MK-6800, MK-6900, MK-7100, MK-8800 and MK-8900.
Dimensions	2-1/2 H x 4-1/2 W x 3 D in. (64 x 114 x 76 mm).

Accessories

Part Number
TOOL-095-1
PKG-1089

Description
Pneumatic calibration tool kit.
Spring and feedback arm kit for AK-42309-500 (included with AK-42309-500).

Typical Applications

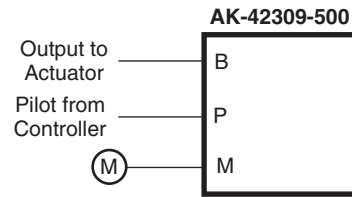

Figure 1 Piping Connections.

Positive Positioning Relay

The N800-0555 is used with M556 (6 in. stroke), M573 (3 in. stroke), and M574 (4 in. stroke) damper actuators.

The N800-0555 is pilot-operated, providing excellent response to small signal pressure changes from the controller.

Pilot-operation also provides maximum resistance to actuator shaft displacement caused by outside force changes.

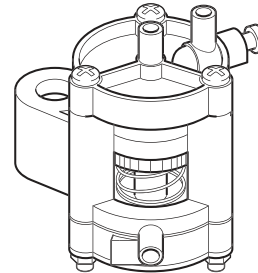

Features:

A built-in adjustable needle-valve permits setting the desired rate of actuator movement, helpful in two ways:

- Various size actuators operated by the same control signal can be made to operate at approximately the same rate of movement, since the smaller actuators can be slowed to match the rate of movements of larger actuators. One example: Outdoor, return and relief dampers of Air-Handling-Units, where the return damper is frequently smaller, and has a smaller actuator.
- Some rapidly changing processes are easier to control if the actuator moves slowly. Examples:
 - Duct static-pressure control.
 - Duct air-velocity control.
 - Control of the mixed-air-temperature of air-handling units, where the mixed-air-temperature changes instantly as the dampers change position. Since no sensor responds instantly, more stable control can be attained if the dampers move slowly. This, in turn, may allow use of a narrower controller throttling range.

Actuators may be ordered with positioners mounted. For field-mounting, feedback arm and spring must be ordered separately. Refer to Model Chart.

Model Chart	
Model No.	Description
N800-0555-BOX	Positioner only.
N800-0555-P	Positioner kit. Includes one positioner, one feedback arm, and 5 and 10 psi feedback springs for M556 (6 in. stroke), M573 (3 in. stroke), and M574 (4 in. stroke).

Specifications	
Environment	
Ambient Temperature Limits	-20 to 140°F (-29 to 60°C).
Supply Air Pressure	Clean, dry, oil-free air required (refer to EN-123).
Nominal	20 psig (136 kPa).
Maximum	30 psig (207 kPa).
Air Consumption	30 scim (8 mL/s).

Air Switching Devices

Table of Contents

AL-15x.....	30
AL-161-4.....	32
AL-17x, AL-18x Series.....	34
AL-19x Series.....	36

All specifications are nominal and may change as design improvements are introduced. Schneider Electric shall not be liable for damages resulting from misapplication or misuse of its products.

Solenoid Air Valve

For applications where an electrical circuit is used to control a pneumatically operated device. Used to direct supply air to a pneumatic device when the coil is energized or de-energized depending on the supply and exhaust air connections. May be used for selection or diverting applications.

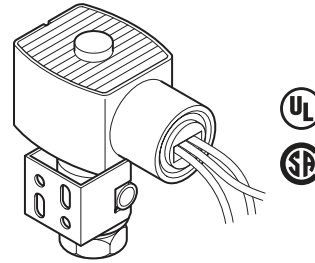

Features:

- High capacity of AL-15x Series allows operation of more devices.
- Brass body receives 1/8 in. male NPT fittings for simple connections to either polyethylene or copper tubing.
- Includes mounting bracket.
- When a 1/8 in. fitting is installed, it secures the body of the valve to the mounting bracket.

Model Chart

Model No.	Voltage (AC 60 Hz)
AL-150	24
AL-151	120

Specifications

Valve inputs

Power input	9.1 Watts (energized).
Available voltages	Refer to model chart.
Electrical connections	18 in. (457 mm) leads on the coil. Threaded hole for 1/2 in. conduit.
Maximum inlet air pressure	40 psig (276 kPa). Clean, dry, oil free air is required (refer to EN-123).
Air connections	1/8 in. MNPT. N.C.: Normally closed, Port 2. N.O.: Normally open, Port 3. COM: Common, Port 1.

Valve outputs

Flow capacity	1988 scim (543 mL/s) at 15 psig (138 kPa) supply with 1 psig (6.9 kPa) drop.
----------------------	--

Environment

Ambient temperature limits	Shipping: -40 to 150°F (-40 to 65°C). Operating: 32 to 125°F (0 to 52°C). Supply air: 40 to 130°F (4 to 54°C).
Humidity	50 to 95% RH, non-condensing.
Location	NEMA Type 4X (IP56).
Dimensions	3-5/32 H x 2-3/4 W x 2 D in. (80 x 70 x 51 mm).

Typical Applications

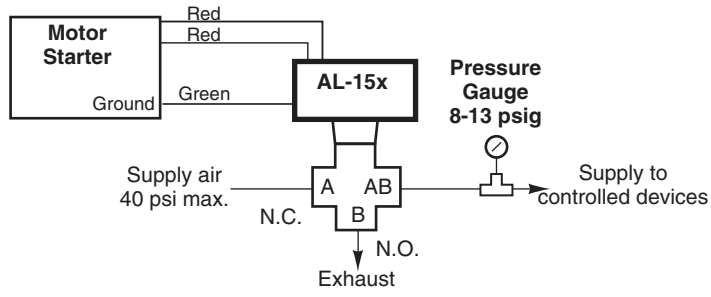

Figure 1 Typical Application Wiring Diagram.
(Air-Handling Unit Application)

Air Switching
Devices

Air Switching Valve

Three-way air switching valve is used for central supply air changeover in dual pressure systems.

Features:

- Compact size
- Large air capacity.

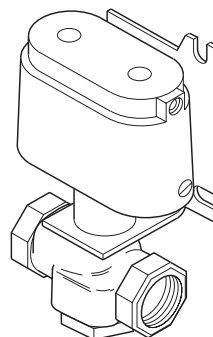

Model Chart

Model No.	Flow Pattern			
	Stem Up [No Air to Actuator]		Stem Down [20 psig (138 kPa) Air to Actuator]	
	Flow	Closed Port	Flow	Closed Port
AL-161-4	B to AB ^a	A	A to AB ^a	B

^a AB Common.

Specifications

Construction

Body	Bronze.
Actuator	Die cast aluminum with replaceable neoprene diaphragm.
Body rating	250 psig (1724 kPa).
Maximum air pressure (actuator)	30 psig (207 kPa).
Spring range	8 to 13 psig (55 to 90 kPa).
Flow capacity	25,920 scim (7,080 mL/s) at 15 psig (103 kPa) supply with 1 psig (6.9 kPa) drop.
Ambient temperature limits	
Shipping and storage	-40 to 220°F (-40 to 104°C).
Operating	40 to 130°F (4 to 54°C).
Supply air	40 to 130°F (4 to 54°C).
Port code and flow pattern	Refer to Model Chart.
Connections	
Actuator	1/8 in. FNPT.
Valve body	1/2 in. FNPT.
Mounting	In any position to wall or subpanel of a cabinet with factory assembled mounting bracket.
Dimensions	6-1/4 H x 3 W x 2-13/16 D in. (159 x 76 x 71 mm).

Typical Applications

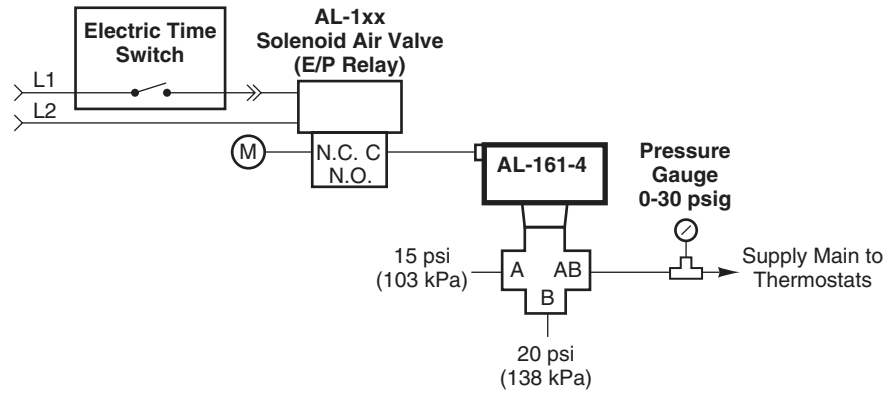

Figure 1 Typical Application.

Air Switching
Devices

Solenoid Air Valves

For applications where an electrical circuit is used to control a pneumatically-operated device. Used to direct supply air to a pneumatic device when the coil is energized or de-energized, depending on the supply and exhaust air connects.

Features:

- Open frame or junction box construction. accommodates a wide variety of NEMA 1 (IP10) mounting locations.
- Available in 24, 120, or 240 Vac models.
- Supplied with 18 in. electrical leads for ease of installation.
- Corrosion-resistant plastic body.
- Barbed fittings for 1/4 in. O.D. plastic tubing.

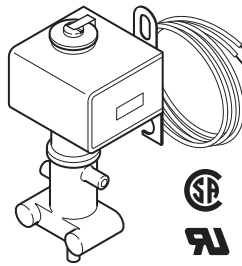

AL-17x

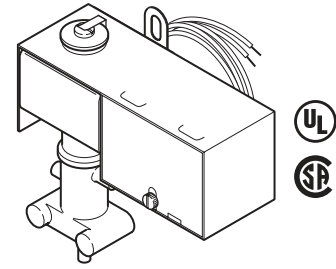

AL-18x

Model Chart		
Model No.		Voltage (AC 60 Hz)
Open Frame	J-Box	
AL-170	AL-180	24
AL-171	AL-181	120
—	AL-183	240

Specifications

Valve inputs	
Power input	5.7 Watts (energized). 17.3 VA Inrush. 9.2 VA Holding.
Voltage	For available voltages, refer to Model Chart.
Electrical connections	18 in. (457 mm) leads on the coil.
Maximum inlet air pressure	30 psig (207 kPa). Clean, dry, oil free air is required (refer to EN-123).
Air connections	Three plastic ferrules included for 1/4 in. O.D. plastic tubing. N.C., Normally closed, Port 1. N.O., Normally open, Port 2. COM, Common, Port 3.
Valve outputs	
Flow capacity	519 scim (142 mL/sec) at 15 psig (103 kPa) supply with 1 psig (6.9 kPa) drop.
Environment	
Ambient temperature limits	Shipping: -40 to 150°F (-40 to 65°C). Operating: 40 to 130°F (4 to 54°C). Supply air: 40 to 130°F (4 to 54°C).
Humidity	50 to 95% RH, non-condensing.
Location	NEMA Type 1 (IP10).
Mounting	Vertical with solenoid at top (as shown).
Dimensions	
AL-17x	3-5/16 H x 1-9/16 W x 1-7/32 D in. (84 x 40 x 31 mm).
AL-18x	3-3/4 H x 3-13/16 W x 1-3/8 D in. (95 x 97 x 35 mm).

Typical Applications

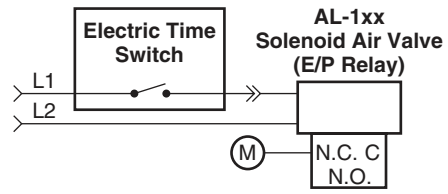
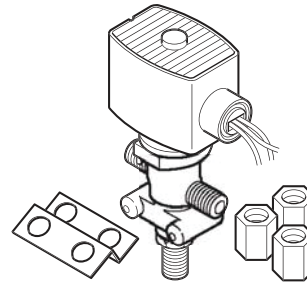

Figure 1 Typical Application Diagram.

Solenoid Air Valve

For applications where an electrical circuit is used to control a pneumatically operated device. Used to direct supply or control air to pneumatic devices when the coil is either energized or de-energized, depending on the supply and exhaust air connections.



Air Switching Devices

Features:

- Plastic corrosion-resistant body provides long life.
- Mounting bracket and fittings for 1/4 in. O.D. plastic tubing supplied with valve for simple, quick installation.
- High capacity of AL-19x Series allows more devices to be used with fewer solenoid air valves.

Model Chart	
Model No.	Voltage (AC 60 Hz) +10/-15%
AL-190	24
AL-191	120

Specifications

Valve inputs	
Power input	9.1 Watts (energized).
Available voltages	Refer to Model Chart.
Electrical connections	18 in. (457 mm) leads on the coil. Coil leads are red; ground lead is green. Threaded hole for 1/2 in. conduit connector. Accepts 1/2 in. EMT fittings.
Maximum inlet air pressure	30 psig (345 kPa). Clean, dry, oil free air is required (refer to EN-123).
Air connections	For 1/4 in. compression fittings. Three compression fittings for 1/4 in. plastic tubing supplied with each valve. N.C., Normally closed, Port 2. N.O., Normally open, Port 3. COM, Common, Port 1.
Valve outputs	
Flow capacity	1020 scim (278 mL/sec) at 15 psig (103 kPa) supply with 1 psig (6.9 kPa) drop.
Environment	
Ambient temperature limits	Shipping: -40 to 150°F (-40 to 65°C). Operating: 32 to 130°F (0 to 54°C). Supply air: 40 to 130°F (4 to 54°C).
Humidity	5 to 95% RH, non-condensing.
Location	NEMA Type 4X (IP56).
Dimensions	4-5/16 H x 3-7/16 W x 1-5/8 D in. (110 x 87 x 43 mm).

Typical Applications

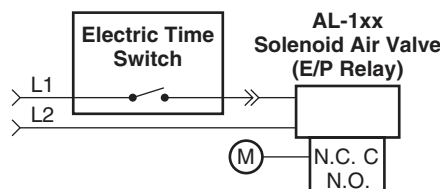

Figure 1 Typical Application Wiring Diagram. (Air-Handling Unit Application)

Control Panel Enclosures and Devices

Table of Contents

Enclosures

AE-6xxx	38
-------------------	----

Gauges

2420 Series	39
2422 Series	40

Receiver-Controllers

2341-5xx	42
RKSR-4000	45

Relays

2353-5xx	47
2354 Series	49
2360-501	51
2368-5xx Series	53
2372-3xx Series	55
2372-5xx Series	57
2373-501	60
2374-401	62
2376-501	64
2378-501	66
2379-501	68
AKR-40605	70

Switches

2364-2xx Series	72
2390 Series	74
239x-500 Series	76
2390-515	78
AFS Series	79
AKS-1100	82
PC-1xxx	81

All specifications are nominal and may change as design improvements are introduced. Schneider Electric shall not be liable for damages resulting from misapplication or misuse of its products.

AE-6xx Series

Control Cabinets

Control cabinets for mounting of electric, electronic, and pneumatic controls.

Features:

- A variety of control cabinets enables selection of the best unit to suit the application.

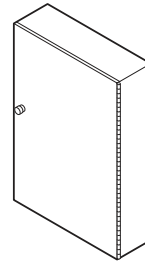

AE-630
AE-631

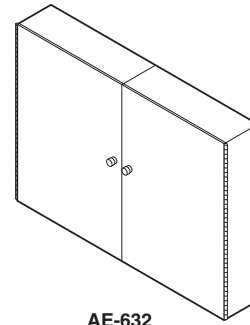

AE-632

Model Chart

Model No.	Door		Steel Gage	Subpanel	Finish	Knockouts	Dimensions W x H x D in. (mm)
	Type	Opening					
AE-630	Single, continuously hinged	Right or left-handed	18	AE-630-101 or obtain locally	Beige paint	For 3/4 in. conduit, two on each side	16 x 24 x 7 (406 x 610 x 178)
AE-631				AE-631-101 or obtain locally			24 x 32 x 7 (610 x 813 x 178)
AE-632	Double, continuously hinged	Right and left-handed	16	Obtain locally, one or two subpanels may be used			42 x 36 x 7 (1067 x 914 x 178)
Subpanel							
AE-630-101	Subpanel for AE-630, 16 gage, perforated for #8 Type A sheet metal screws, flanged						14-1/2 x 20 (368 x 508)
AE-631-101	Subpanel for AE-631, 16 gage, perforated for #8 Type A sheet metal screws, flanged						22-1/2 x 28 (572 x 711)

Specifications

Construction

Doors	Locking type, supplied with keys, rigidly supported. The doors are easily removed for protection on job site installation or mounting of components. Refer to Description Model Chart.
Steel Gage	Refer to Description Model Chart.
Knockouts	Aligned so that a short nipple may be used to couple the panels. Refer to Description Model Chart.
Appearance	Refer to Description Model Chart.
Locations	NEMA Type 1 (IP10).
Mounting	Four extruded mounting holes 1/4 in. (6mm).
Dimensions	Refer to Description Model Chart.

Pressure Gauges

Pressure gauges for continuous indication of air pressure in pneumatic control systems.

Features:

- 0 to 30 psig (0 to 200 kPa) models permit readout of main air pressure and/or output pressures of pneumatic control components.
- 0 to 160 psig (0 to 1100 kPa) models permit readout of pressure in air-compressor receivers or high-pressure main air lines.
- Available in flush-mounted, stem-mounted, bottom-mounted or lower-back mounted models.

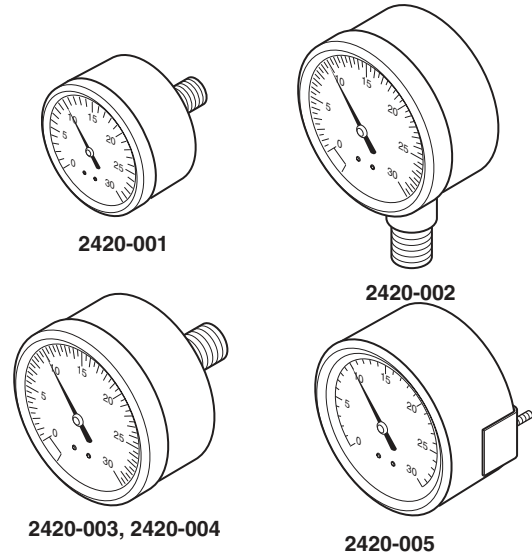

Model Chart						
Model No.	Replaces Model No.	Dial Size in. (mm)	Range psi (kPa)	Mounting	Air Connection	Construction and Finish
2420-001	A201/AL-362	1-1/2 (38)	0 to 30 (0 to 200)	Stem	1/8 in. MNPT center back	ABS plastic case and friction ring
2420-002	A203				1/8 in. MNPT bottom	
2420-003	A204-3/AL-322		0 to 160 (0 to 1100)		1/8 in. MNPT center back	
2420-004	A204-4/AL-327					
2420-005	A205-01	2 (51)	0 to 30 (0 to 200)	Flush	1/4 in. barb back 1/8 in. MNPT lower back	Steel case; black enamel case with chrome plated brass rings

Specifications	
Gauge actuation	Phosphor bronze Bourdon tube through sturdy brass gears.
Flush panel mounting	2420 Series U-clamp mounting for panels 1/16 to 3/4 in. thick.
Dimensions	
2420-001	1-42/64 x 1-1/2 in. (34 x 38 mm).
2420-002	1-15/32 x 1-3/32 in. (37 x 27 mm).
2420-003, 2420-004	2-11/64 x 1-55/64 in. (55 x 28 mm).
2420-005	2-1/4 x 1-53/64 in. (57 x 46 mm).

Control Panel Enclosures and Devices

Receiver Gauges

Receiver gauges for continuous indication of temperature, differential static pressure, differential pressure, pressure, enthalpy, or humidity in conjunction with a transmitter-receiver system. Select “donut” type dials listed for required application.

Features:

- Receiver-gauges receive output signals of pneumatic transmitters and provide readout of measured (and/or controlled) variables at convenient locations.
- Gauge dials available to match each pneumatic transmitter range.
- 2 in. model available for stem mounting.
- 2-1/2 and 3-1/2 in. models available for flush mounting.

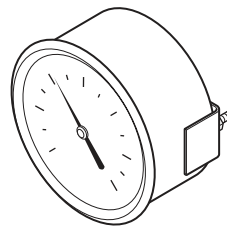

2422-001, -002

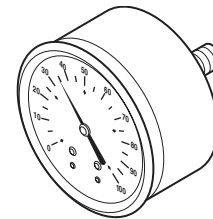

2422-003

Control Panel Enclosures and Devices

Model Chart						
Model No.	Replaces Model No.	Dial Size In.	Pointer	Mounting	Air Connection	Construction and Finish
2422-001 ^{a b}	A251-1	2-1/2	Adjustable	Flush with “U” clamp for panels	1/8 in. MNPT center back	Black plastic case with chrome plated snap-out ring
2422-002 ^{a c}	A252	3-1/2				
2422-003 ^{a d}	A253-12	2		Stem		Black plastic case

^a Each gauge kit includes a gauge and a gauge overlay kit.
^b To replace 2-1/2 in. gauge overlays, order overlay kit 2890-002.
^c To replace 3-1/2 in. gauge overlays, order overlay kit 2890-003.
^d To replace 2 in. gauge overlays, order overlay kit 2890-001.

Gauge Overlay Kits (included with gauge).

2890-001	2890-002	2890-003
Overlay Kit for 2" Dia. 2422-003 Gauges	Overlay Kit for 2-1/2" Dia. 2422-002 Gauges	Overlay Kit for 3-1/2" Dia. 2422-001 Gauges
Blank ^a	Blank ^a	Blank ^a
0 to 200°F	0 to 200°F	0 to 200°F
25 to 125°F	25 to 125°F	25 to 125°F
40 to 100°F	40 to 100°F	40 to 100°F
3 to 15 psig	3 to 15 psig	3 to 15 psig
40 to 140°F	0 to 100°F	0 to 100°F
40 to 240°F	40 to 140°F	40 to 140°F
-40 to 160°F	40 to 240°F	40 to 240°F
-25 to 125°F	-40 to 160°F	-40 to 160°F
50 to 90°F	-25 to 125°F	-25 to 125°F
62.5 to 92.5°F 30% to 80% RH	50 to 90°F	50 to 90°F
0 to 3 in. WC	62.5 to 92.5°F	62.5 to 92.5°F
0 to 10 in. WC	30% to 80% RH	30% to 80% RH
50 to 100°F	0 to 3 in. WC 0 to 10 in. WC 50 to 100 in. WC	0 to 3 in. WC
		0 to 10 in. WC
		50 to 100°F

^a Five majors with nine minors per major can be field customized

Specifications	
Air pressure	3 to 15 psig (21 to 103 kPa).
Construction	
Case	Refer to Model Chart.
Lens	Clear plastic.
Gauge actuation	Bronze Bourdon tube through sturdy brass gears.
Gauge dimensions	
2422-001	2-29/32 (74 mm) dia. x 2-1/2 (64 mm) D in.
2422-002	4 (102 mm) dia. x 2-1/2 (64 mm) D in.
2422-003	2-15/64 (57 mm) dia. x 1-53/64 (46 mm) D in.

Typical Applications

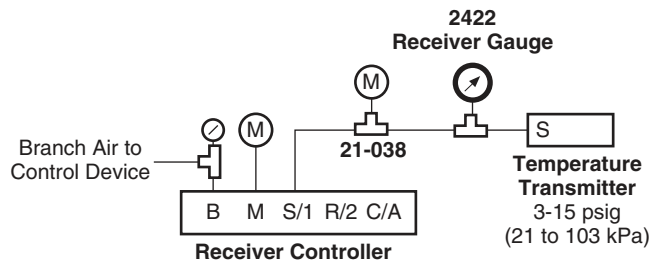

Figure 1 Typical Application.

Notes:

Receiver-Gauges may be connected at any point in the line between the transmitter and the receiver-controller (i.e., on either side of the restrictor-tee). More than one receiver-gauge may be connected to the same line if required.

Pneumatic Receiver Controller

The receiver controllers are used with remote pneumatic transmitters to provide proportional control in pneumatic control systems. They are designed primarily for use with pneumatic transmitters; however, they may be used with any pneumatic device having an output of 3 to 15 psig, such as thermostats or humidistats. Both direct and reverse acting models are available and each device is of the dual-input type, with remote setpoint capability. These devices may be used as single input devices by using only the desired input.

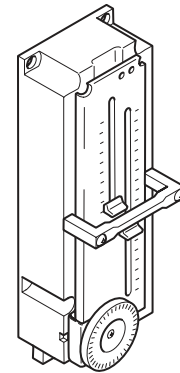

Receiver-Controller

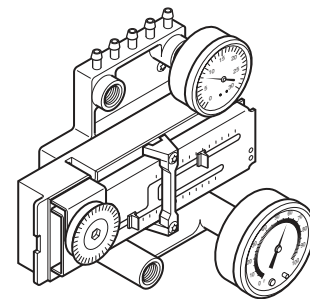

Receiver-Controller Mounted on Base
(gauges ordered separately)

Features:

- Nozzle and flapper relay- type receiver-controller; linear, stable and responsive. Three inputs for primary, reset, and remote control point adjustment (may be used with one or two inputs).
- Slide-type throttling range and authority adjustments are easy to use, require no tools. Easy setpoint calibration.
- Five barbed connections for 1/4 in. O.D. plastic tubing.
- Setpoint dials available to match transmitter ranges.
- Available in direct-acting and reverse-acting models.
- Direct-acting models have a built-in low-limit feature. Reverse-acting models have a built-in high-limit feature.
- Designed for mounting on Socket Kit MCS-S-P; may be mounted as stand-alone controller with P541-BASE.

Model Chart			
Model No.	Replaces Model No.	Action	Description
2341-501	P541	Direct	Direct Acting Receiver Controller only
2341-502	P541-RA	Reverse	Reverse Acting Receiver Controller only
2341-521	P541-DA-B	Direct	Direct Acting Receiver Controller (2341-501) mounted to a Base P541-BASE
2341-522	P541-RA-B	Reverse	Reverse Acting Receiver Controller (2341-502) mounted to a Base P541-BASE
P541-BASE	—	Not applicable	Mounting Base, Gasket and Mounting Screws

Specifications

Construction	Glass-filled nylon.
Control action	Direct acting or reverse acting, determined by model selection.
Supply air pressure	Clean, dry, oil free air required (refer to EN-123).
Normal	4 to 22 psig (28 to 152 kPa).
Maximum	30 psig (207 kPa).
Air consumption	36 scim (9.8 mL/s), maximum.
Air flow capacity	13824 scim (3774 mL/s).
Connections	Barbed nipples for 1/4 in. O.D. polyethylene tubing-for optional base. 5/32 in. I.D. polyurethane tubing for MCS-S-P socket mounting.
Authority	Adjustable; 10 to 300% of primary signal input.
Reset action	Port R (reset signal) provides reverse reset. To obtain direct reset requires 2341-502 with 60% authority and 40% throttling range to reverse the transmitter's 3 to 15 psi (20.7 to 103.4 kPa) signal to 15 to 3 psi (103.4 to 20.7 kPa).
Throttling range	Adjustable; 2 to 40%/12 psi.
Setpoint	Adjustable; graduated dial with 0.25 psi divisions.
CPA (remote setpoint adjustment)	±10% of primary transmitter span.
Ambient temperature limits	40 to 140°F (4 to 60°C).
Mounting	Designed for use on MCS-S manifold socket. These devices can also be surface mounted by using an optional 22-152 mounting bracket or by ordering with base option.
Dimensions	
2341-50x	1-63/64 H x 5-25/32 W x 2-1/4 D in. (50 x 147 x 57 mm).
2341-52x	3-5/8 H x 5-13/16 W x 3-3/4 (136 x 148 x 95 mm).

Accessories

Part Number	Replaces Model	Description
20-881	N2-4	Calibration wrench.
21-038	N100-0010	Restrictor tee polyethylene tubing.
21-153	N100-2501	In-line restrictor.
900-012	N100-2597	Calibration kit.
2390-501	S510	Gradual switch.
2390-505	S511-5	Minimum switch position (5 psig span).
2390-510	S511-10	Minimum switch position (10 psig span).

Typical Applications

Active Connections.

Port	Connected to
B	Branch output.
M	Main air.
S	Primary signal input.
R	Reset signal input.
C	Control point adjustment.

2341-5xx Series

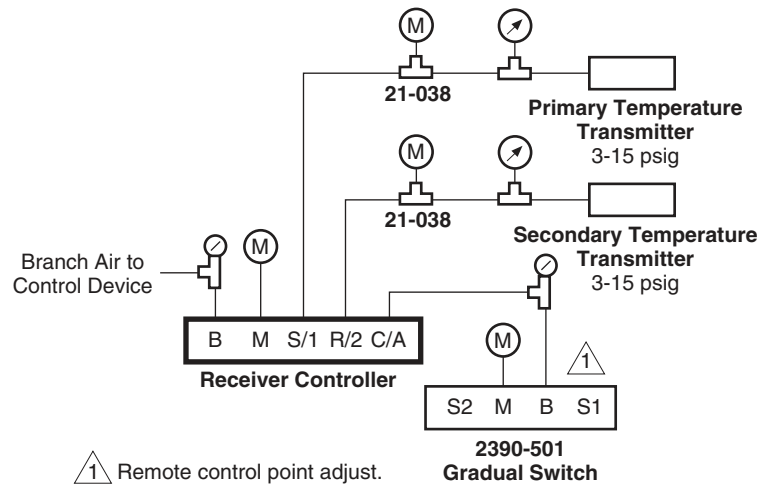
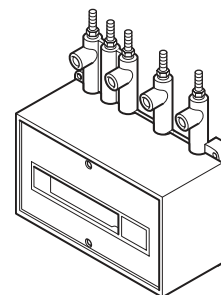

Figure 1 Typical Application.

Single/Dual Transmitter Input Receiver Controllers

For use in conjunction with remote proportional transmitters for proportional control of pneumatic actuated dampers, valves, etc., in air conditioning systems. The transmitter-receiver-controller system may be used to control temperature, humidity, or pressure.



RKSR-4000

Features:

- Nozzle and flapper relay-type receiver controller.
- Linear, stable and responsive.
- Universal model works with one, two or three inputs.
- Mounting provided for two (1/8 NPT) 1-1/2 in. stem-mounted receiver-gauges and two 1-1/2 in. stem-mounted pressure gauges.
- Barbed fittings for 1/4 in. O.D. plastic tubing.
- Setpoint scales available to match transmitter ranges.
- Rebuildable

Model Chart						
Model No.	Description	Remote SPA	Action ^a	Type	Authority ^b	Proportional Band
RKSR-4000	Replacement single or dual input ^c	±10% of primary transmitter span	D.A./R.A.	Two Pipe	10% to 200% of primary (input 1) transmitter span adjustable	2-1/2% to 40% of primary (input 1) transmitter span adjustable

^a D.A. (Direct Acting) factory shipped: increases output pressure on rise in input 1 pressure. Field changeable to R.A.

R.A. (Reverse Acting): decreases output pressure on rise in input 1 pressure.

^b Primary transmitter connects to input 1.

^c Input 2 has a reverse acting reset only. For direct acting the output pressure increases as input 2 increases. For reverse acting the output pressure increases as input 2 decreases.

Specifications	
Receiver-controller	Forced balanced pneumatic amplifier.
Setpoint	Adjustable, °F, °C, in. water, mm water, % relative humidity labels (included with controller).
Proportional band	Field adjustable.
Input signals	3 to 15 psig (21 to 103 kPa). Maximum input pressure 30 psig (207 kPa).
Output air signal	0.5 psig (3.4 kPa) to supply air pressure -0.5 psig (-3.4 kPa).
Action	Direct. Field changeable to reverse.
Authority	
RKSR-4000	Field adjustable.
Ambient temperature limits	
Shipping and storage	-40 to 150°F (-40 to 65°C).
Operating	40 to 150°F (4 to 65°C).
Humidity	10 to 98% RH, non-condensing.
Supply air pressure	Clean, oil free, dry air required (refer to EN-123).
Nominal	20 psig (138 kPa).
Minimum	18 psig (124 kPa).
Maximum	30 psig (207 kPa).
Air connections	
Tubing	Barb connectors for 1/4 in. O.D. plastic tubing.

Control Panel Enclosures and Devices

Specifications (Continued)

Air consumption for sizing air compressor	13.8 scim (3.8 mL/s) plus 41.5 scim (11.4 mL/s) for each transmitter and remote setpoint.
Air capacity for sizing air mains	16 scim (4.4 mL/s) plus 36 scim (13.2 mL/s) for each transmitter and remote setpoint.
Cover	Factory supplied.
Mounting	Upright on surface of wall or panel.
Dimensions	5-23/32 H x 7 W x 4 D in. (145 x 178 x 102 mm).

Accessories

Model No.	Description
20-944	Restrictor tee, copper tubing.
21-038	Restrictor tee, polyethylene tubing.
21-153	In-line restrictor.
2232-053	Room humidity transmitter.
2220-053	Room temperature transmitter.
2420-001	1-1/2 pressure gauge stem mounted back connected 0 to 30 psi gauge.
2422-003	2" receiver gauge, back-mounted 1/8 NPT
AKS-1100	Remote setpoint adjuster.
AT-539	Pilot pressure kit for RKSR-4000.
TOOL-095-1	Pneumatic calibration tool kit.
Maintenance Parts	
AT-520-11	Relay repair kit.
AT-523-20	Nozzle kit.
AT-523-30	Input diaphragm kit (parts for 3 inputs).
AT-524-10	Input restrictor kit.
AT-528	Pilot restrictor kit.

Typical Applications

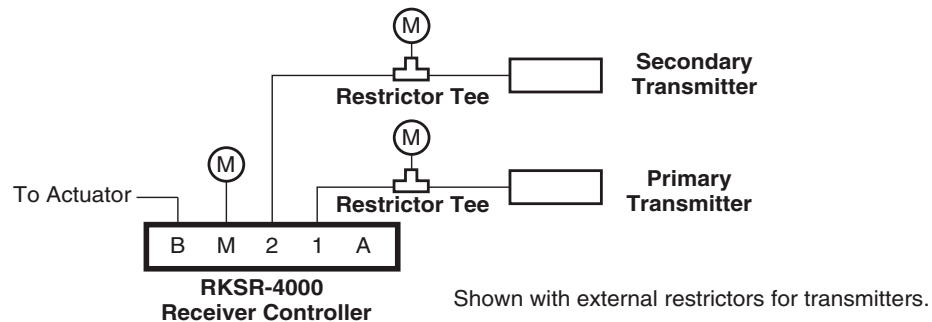

Figure 1 Typical Piping for RKSR-4000 Dual Input Receiver-Controller (External Restrictors for the Transmitters).

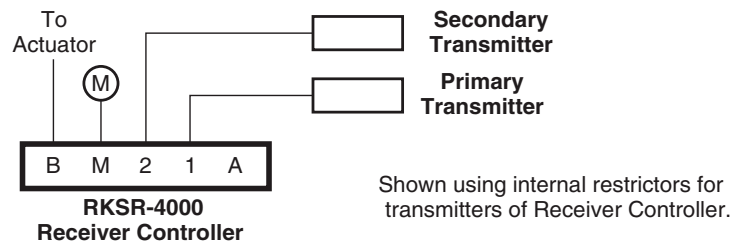

Figure 2 Typical Piping for RKSR-4000 Dual Input Receiver-Controller (Internal Restrictors for the Transmitters).

NOTES:

1. When external restrictors are used, the transmitter must be located within 1000 ft. (305 m) of the receiver-controller, and the restrictor must be located within 200 ft. (61 m) of the transmitter (preferably at the transmitter's location). Remove internal restrictors from receiver-controller and install blocking gaskets.
2. When internal restrictors are used, the transmitter must be located within 200 ft. (61 m) of the receiver-controller.

Pneumatic Diverting Relays

The 2353-501 and 2353-502 diverting relays are snap-acting devices with adjustable setpoints. They are designed for a variety of switching and interlocking functions in pneumatic control systems where the application requires one or more of the following functions: feeding and exhausting branch lines, diverting a supply line to either one of two branch lines, or diverting one of two supply lines to one branch line. The primary function of these devices is to convert a proportional pneumatic signal, at a predetermined setting, into a positive pneumatic switching action.

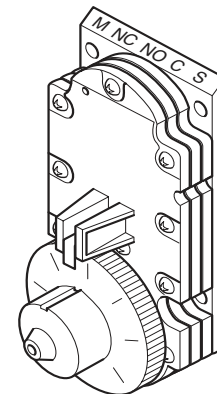

2353-501
2353-502

Features:

- All 2353 Series Relays provide positive two-position snap-action, provide SPDT pneumatic switching. Require main air supply.
- 2353-501 and 2353-502 have setpoint dial with PSIG markings.
- 2353-501 has narrow differential; to be piloted by transmitter signals.
- 2353-502 has wide differential; to be piloted by controller signals.
- All ports clearly labeled. Ports align with 22-120 socket terminals.
- Mounts on MCS-S-P Socket Kit or 22-150 Mounting Bracket.

Model Chart						
Model No.	Replaces Model No.	Type	Differential psi (kPa)	Setpoint Range psig (kPa)	Switching Action	Dimensions in. (mm) H x W x D
2353-501 ^a	R503-1	SPDT	0.2 to 0.6 (1.4 to 2.8)	3 ^b to 20 (21 to 138)	Port S at setpoint minus diff.: ports NO and C are connected. Port S at setpoint: ports NC and C are connected.	4-1/8 x 1-31/32 x 3-9/64 (105 x 50 x 80)
2353-502 ^a	R503-2		2 to 4 (14 to 28)	4.5 ^b to 20 (31 to 138)		4-1/2 x 1-31/32 x 2-55/64 (114 x 50 x 73)

^a Includes two plastic mounting straps and adhesive backed mounting plate.

^b DO NOT SET below this value.

Specifications	
Control action	Refer to Model Chart.
Construction	Glass-filled nylon.
Maximum ambient temperature	140°F (60°C).
Supply air pressure	Clean, dry, oil free air required (refer to EN-123).
Nominal	15 to 25 psig (103 to 172 kPa).
Maximum	30 psig (207 kPa).
Connections	Barbed nipples for 1/4 in. O.D. tubing.
Air consumption	29 scim (7.9 mL/s).
Air flow capacity	60 scfh (1.7 scmh).
Adjustments	Knob operates over two revolutions. A moving pointer slide is provided to indicate both inner and outer scales.
Mounting	Designed for use on MCS-S-P Socket Kit. These devices can also be surface mounted by using the 22-150 mounting bracket.
Dimensions	Refer to Model Chart.

2353-5xx Series

Active Connections

Port	Description
M	Main.
S	Signal.
C	Common.
NO	Normally open.
NC	Normally closed.

Accessories

Part Number	Replaces Model	Description
22-150	K502	Optional mounting bracket.
TOOL-082	—	5/64 in. hex wrench.
22-120	—	Socket.
MCS-S-P	—	Socket kit.

Typical Applications

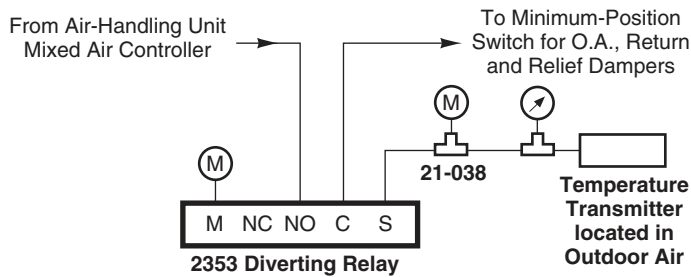

Figure 1 2353-501, 2353-502 Typical Application.

Pneumatic Diverting Relays

The 2354 Series diverting relays are snap-acting devices designed for a variety of switching and interlocking functions in pneumatic control systems where the applications may require one or more of the following functions: feeding and exhausting branch lines, diverting a supply line to either one of two branch lines or diverting either one of two supply lines to one branch line.

Features:

- All 2354 Series Relays provide positive two-position snap-action. No main air connection required.
- Some competitive relays, that are claimed to be snap-acting, are not.
- 2354-501 and 2354-502 are the same relay with different factory settings; provide SPDT pneumatic switching.
- 2354-503 and 2354-504 are the same relay with different factory settings; provide DPDT pneumatic switching (switch two separate pneumatic circuits simultaneously).
- Switching point adjustable with 1/16 in. hex wrench.
- All ports clearly labeled. Ports align with 22-120 socket terminals.
- Mounts on MCS-S-P Socket Kit or 22-150 Mounting Bracket.

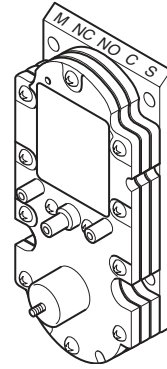

Model Chart

Model No.	Replaces Model No.	Switching Action	Range psig	Action
2354-501 ^a	R504-1	SPDT	4 to 8	Below 4 psig: NO and C are connected. Above 8 psig: NC and C are connected.
2354-502 ^a	R504-2		18 to 22	Below 16 psig: NO and C are connected. Above 20 psig: NC and C are connected.
2354-503 ^a	R504-3	DPDT	4 to 8	Below 4 psig: NO and C are connected. NO2 and C2 are connected. Above 8 psig: NC and C are connected. NC2 and C2 are connected.
2354-504 ^a	R504-4		18 to 22	Below 16 psig: NO and C are connected. NO2 and C2 are connected. Above 20 psig: NC and C are connected. NC2 and C2 are connected.

^a Includes two plastic mounting straps and adhesive backed mounting plates.

Specifications

Control action	Refer to Active Connections Table.
Construction	Glass-filled nylon.
Maximum ambient temperature	140°F (60°C).
Supply air pressure	Clean, dry, oil free air required (Refer to EN-123).
Maximum	30 psig (207 kPa).
Connections	Barbed nipples for 1/4 in. O.D. polyethylene tubing.
Air flow capacity	60 scfh (1.7 scmh).
Adjustments	The differential band (fixed at 4 psig) switch-over point may be adjusted between 4 to 8 psig and 18 to 22 psig respectively by means of 1/16 in. hex wrench.
Mounting	Designed for use on 22-120 socket. This device can also be surface mounted by using the 22-150 mounting bracket.
Dimensions	4-1/8 H x 1-31/32 W x 2-61/64 D in. (105 x 50 x 80 mm).

2354 Series

Active Connections

Port	Description
C	Common.
C ₂ ^a	Common no. 2.
NO	Normally open.
NO ₂ ^a	Normally open no. 2.
NC	Normally closed.
NC ₂ ^a	Normally closed no. 2.
S	Input signal.

^a 2354-503 and 2354-504

Accessories

Part Number	Replaces Model	Description
22-150	K502	Mounting bracket.
22-120	—	Socket.
MCS-S-P	—	Socket kit.

Typical Applications

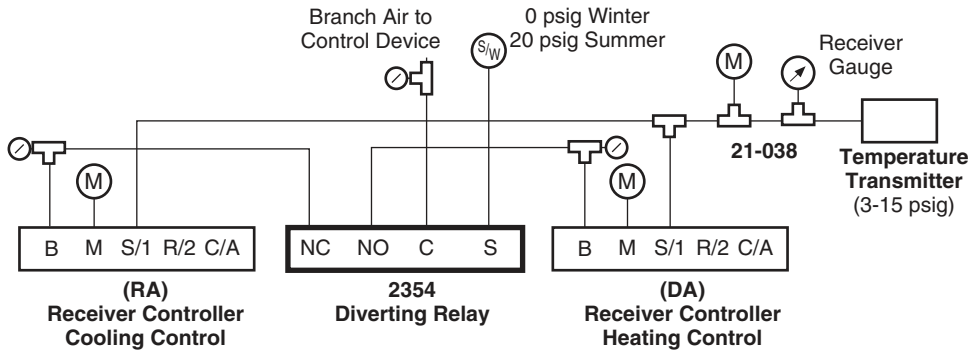
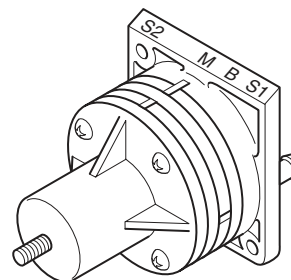

Figure 1 Typical Application.

Pneumatic Reversing Relay

The reversing relay is a proportional device designed for use in pneumatic control systems where the application requires the reversing of a proportional signal from a controlling device. The 2360-501 branch line pressure decreases in direct proportion to an increase in input signal pressure and also amplifies the volume of air available for the final control device, thereby minimizing system lag.

The unit is factory calibrated to decrease the branch line pressure from 16 psig to 0 psig (110 to 0 kPa) as the signal pressure increases from 0 psig to 16 psig (0 to 110 kPa).



Features:

- Clearly marked connections eliminate the need to memorize port numbers: M (Main), B (Branch), and S1 (Input Signal).
- A bias adjustment is provided which can be used to advance or retard the output signal as required for specific applications (refer to Figure 2).
- The 2360-501 may be used as part of the panel-mounted, modular control system, or individually, using a 22-150 manifold backplate and its barbed tubing connections or MCS-S-P Socket Kit.
- Ports align with 22-120 socket terminals.

Model Chart

Model No.	Replaces Model No.	Description
2360-501 ^a	R516	Reversing Relay.

^a Includes plastic mounting strap and adhesive backed mounting plate.

Specifications

Control action	Proportional — reverses input signal.
Construction	Glass-filled nylon.
Maximum ambient temperature	140°F (60°C).
Supply air pressure	
Nominal	20 psig (138 kPa).
Maximum	30 psig (207 kPa).
Connections	Barbed nipples for 1/4 in. O.D. polyethylene tubing.
Main air consumption	29.3 scim (8.01 mL/s).
Air flow capacity	230 scim (62.8 mL/s).
Adjustments	Crossover point, factory set at 8 psig (55 kPa) (8 psig input = 8 psig output), field adjustable 2 to 15 psig (13.8 to 103 kPa).
Mounting	Designed for use on 22-120 socket. This device can also be surface mounted by using the 22-150 mounting bracket.
Dimensions	2-1/16 H x 1-7/8 W x 2-9/64 D (52.4 x 47.6 x 54.4 mm).

Active Connections

Port Designation	Connected to
M	Main air.
B	Branch output.
S1	Input signal.
Note: S2 port is inactive.	

Accessories

Part Number	Replaces Model	Description
22-150	K502	Mounting bracket.
22-120	MCS-S	Socket.
TOOL-082	—	5/64 in. hex wrench.
MCS-S-P	—	Socket kit.

Typical Applications

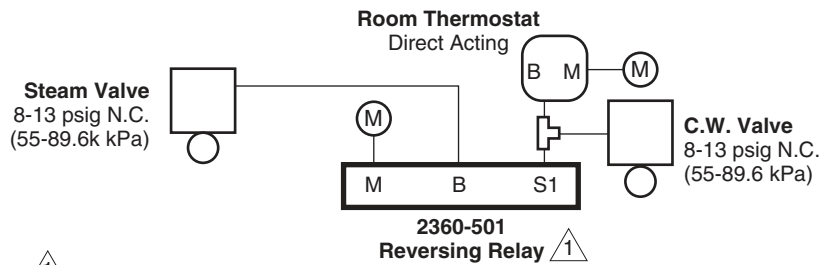

- 1 Set at 8 psig (55 kPa) Crossover
- 2 On Room Temperature Increase: As thermostat branch (output) pressure increases from 3 to 8 psig (20.7-55 kPa), N.C. steam valve modulates from open to closed position. As thermostat branch pressure increases from 8 to 13 psig (55-89.6 kPa), N.C. chilled water valve modulates from closed to open position.

Figure 1 Typical Application.

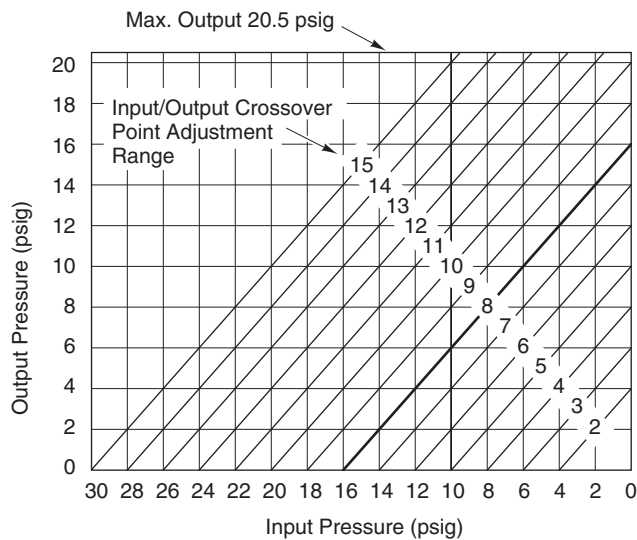

Note: Metric conversion: 6.895 kPa = 1psi

Figure 2 Input vs. Output Pressures.

Pneumatic Electric-Pneumatic Relays

The electric-pneumatic relays are three-way, two-position, electrically activated air valves for use in pneumatic control systems where the application requires a variety of switching, diverting, or interlocking functions, actuated by an electrical circuit. The 2368-50x Series switches one SPDT pneumatic circuit, while the 2368-52x Series switches two independent SPDT pneumatic circuits simultaneously.

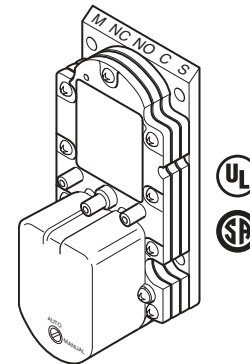

Features:

- 2368-50x Series provides SPDT pneumatic switching (N.C., N.O., C).
- 2368-52x Series provides DPDT pneumatic switching (N.C., N.O., C), plus (N.C.2, N.O.2, C2). Switches two separate circuits simultaneously.
- Manual/auto switch (permits control system testing without starting and stopping electrical equipment).
- All ports clearly labeled. Ports align with 22-120 socket terminals.
- Must be mounted on 22-120 socket and used with 22-122 electrical connector.

Model Chart			
Model No.	Replaces Model No.	Coil Voltage	Switch Action
2368-501	R527-24	24 Vac	SPDT
2368-502	R527-110	110 Vac	
2368-521	R528-24	24 Vac	DPDT
2368-522	R528-110	110 Vac	

Specifications	
Output	3 to 15 psig.
Action	
SPDT models (2368-50x Series)	Coil de-energized, C and NO are connected. Coil energized, C and NC are connected.
DPDT models (2368-52x Series)	Coil de-energized, C and NO are connected, C2 and NO2 are connected. Coil energized, C and NC are connected, C2 and NC2 are connected.
Maximum ambient temperature	140°F (60°C).
Supply air pressure	Clean, dry, oil free air required (refer to EN-123).
Nominal	20 to 25 psig (138 to 172 kPa).
Maximum	30 psig (207 kPa).
Connections	
Air	Barbed fittings for 1/4 in. O.D. polyethylene tubing.
Electrical	Purchase separately the 22-122 electrical connector with screw terminals and the 22-136 electrical barrier.

2368-5xx Series

Specifications (Continued)

Air consumption	1728 scim (471.7 mL/s).
Air flow capacity	1728 scim (471.7 mL/s).
Power consumption	2.2 VA.
Adjustments	Auto, manual switch.
Mounting	Designed for use on 22-120 socket only.
Dimensions	4-1/8 H x 1-1/32 W x 2-55/64 D in. (105 x 50 x 63 mm).

Active Connections

Port	Connected to
M	Main air.
C	Common.
C2 ^a	Common no. 2.
NO	Normally open.
NO2 ^a	Normally open no. 2
NC	Normally closed.
NC2 ^a	Normally closed no. 2.

^a DPDT models only.

NOTE: A loss of main air pressure will have the same effect as de-energizing the coil.

Accessories

Part Number	Replaces Model	Description
22-122	MCS-EC	Electrical contact assembly.
22-136	MCS-EB	Electrical barrier.
22-120	—	Socket.
MCS-S-P	—	Socket kit.
Maintenance Parts		
22-200	—	24 Vac coil.
22-201	—	110 Vac coil.

Typical Applications

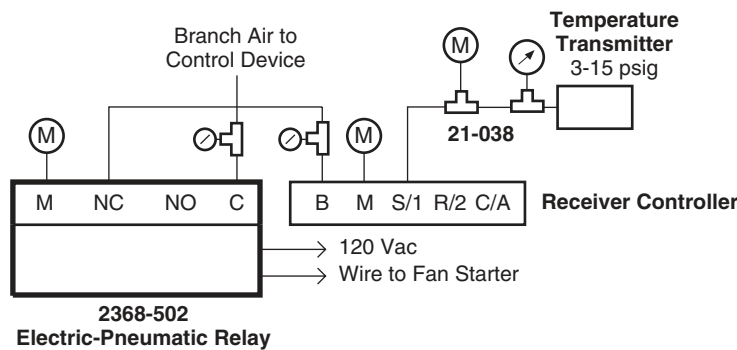
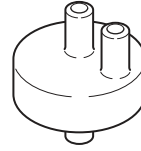

Figure 1 Typical Application.

High Pressure Selector Relay and Low Pressure Selector or Booster Relay

The pressure selector relays are designed for use in pneumatic control systems where the application requires the comparison, selection, and transmission of the higher or lower of two proportional signals. 2372-351 can also be used as a booster relay.



2372-352
High Pressure Selector

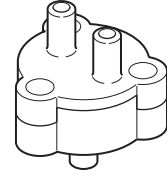

2372-351
Low Pressure Selector
or Booster Relay

Features:

- Relays are non-adjustable.
- Precise repeatability characteristics.
- Small size and light weight allow these relays to be mounted “in-line”, supported by the pneumatic tubing.
- 2372-351 may be used as Booster Relay or LP Selector.
- 2372-352 HP Selector may be used with “restricted” pneumatic signals down to 0.5 SCFH (14.1 L/h) airflow.

Model Chart					
Model No.	Replaces Model No.	Functions	Dimensions in. (mm)	Port Connections	
				Port	Connected to
2372-351	R432-11	Selects the lowest of two input signals. Or may be used as volume booster.	1-3/16 dia. x 1-3/16 (30 x 30)	B	Branch output
				S	Input signal
				M	Input signal (piped to main air when used as a volume booster)
2372-352	R432-2	Selects the highest of two input signals.	1-1/8 dia. x 31/32 (29 x 25)	B	Branch output
				S1, S2	Input signals

Specifications	
Action	Proportional.
Construction	Glass-filled nylon.
Ambient temperature limits	35 to 140°F (2 to 60°C).
Supply air pressure	Clean, dry, oil free air required (refer to EN-123).
Nominal	20 psig.
Maximum	30 psig.
Connections	Fittings for 1/4 in. O.D. plastic tubing.
Air consumption	When used as a volume booster.
Main port	29.4 scim (8 mL/s).
Signal port	0.2 scim (0.1 mL/s).
Mounting	In-line.
Dimensions	Refer to Model Chart.

Typical Applications

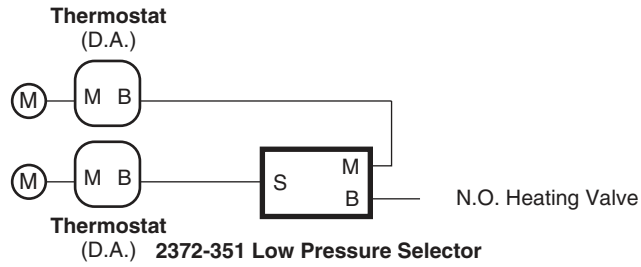

Figure 1 2372-351 Low Pressure Selector Relay.

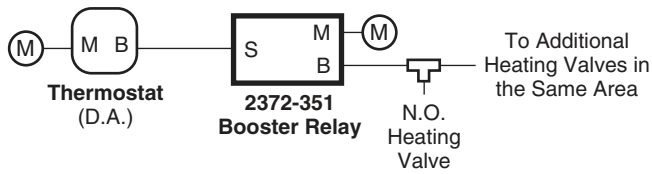

Figure 2 2372-351 Used as Booster Relay.

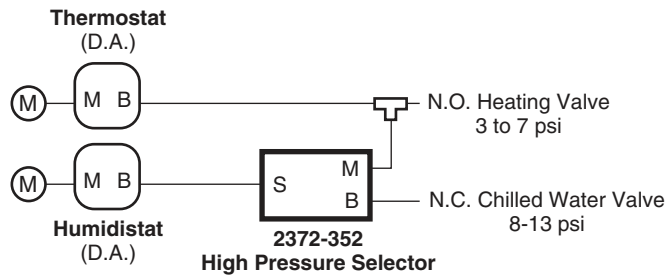
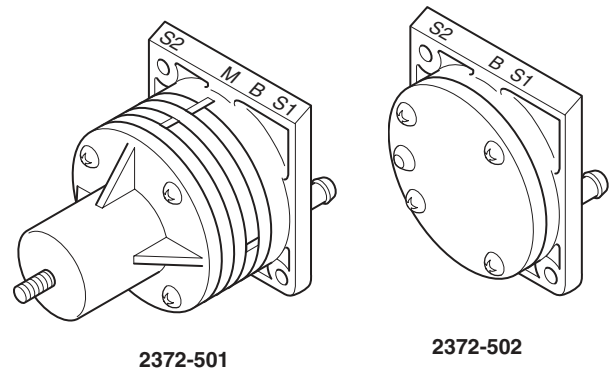

Figure 3 2372-352 High Pressure Selector Relay.

Pneumatic Volume Booster/Pressure Selector Relays

The volume booster relay is a proportional device designed for use in pneumatic control systems where the application requires amplification of control air volume to final control devices. System transmission lag is minimized by using this relay in conjunction with a proportional controller operating several diaphragm valves or damper actuators. This device may also be used as a low pressure selector when the application requires the comparison, selection and transmission of the lower of two proportional input signals.

The high pressure selector relay is a device designed for use in pneumatic control systems where the application requires the comparison, selection, and transmission of the higher of two proportional input signals.



Features:

2372-502

- Two-input high pressure selector; no adjustments.
- All ports clearly labeled.
- Not for use with “restricted” signals (use 2372-352).
- Mounts on MCS-S-P Socket Kit or 22-150 Mounting Bracket. Due to light weight, may be mounted “in-line”, supported by tubing.

2372-501

- 1:1 booster relay with adjustable bias.
- May be used as low pressure selector (using ports S-1 and M).
- Using S-1 and S-2 inputs (and main air supply at M) may be used as summation (adding) relay.
- All ports clearly labeled. Ports align with 22-120 socket terminals.
- Mounts on MCS-S-P Socket Kit or 22-150 Mounting Bracket.

Model Chart				
Model No.	Replaces Model No.	Description	Port Connections	
			Port	Connected to
2372-501 ^a	R532-L	Volume booster or low pressure selector	M	Main air or input signal no. 2
			B	Branch output
			S ₁	Input signal no. 1
2372-502 ^a	R532-H	High pressure selector ^b	B	Output
			S ₁	Input signal no. 1
			S ₂	Input signal no. 2

^a Includes plastic mounting strap and adhesive backed mounting plate.

^b **Note:** Do not use signals from a low volume signal source such as transmitters, or one pipe thermostats. Use 2372-352 for these applications.

Control Panel Enclosures and Devices

2372-5xx Series

Specifications

Control action	Proportional.
Construction	Glass-filled nylon.
Maximum ambient temperature	140°F (60°C).
Supply air pressure	Clean, dry, oil free air required (Ref. EN-123).
Nominal	20 psig (138 kPa).
2372-501 maximum	30 psig (207 kPa).
2372-502 maximum	25 psig (172 kPa).
Connections	Barbed nipples for 1/4 in. O.D. polyethylene tubing.
Main air consumption	29.4 scim (8 mL/s) (applies to 2372-501 when used as a volume booster only).
Air flow capacity	230 scim (62.8 mL/s).
Adjustments	
2372-501	Output may be advanced or retarded ± 5 psi (34.5 kPa).
2372-502	None.
Mounting	On MCS-S-P Socket Kit. For non-manifold mounting use 22-150 mounting bracket.
Dimensions	
2372-501	2-1/16 H x 1-7/8 W x 2-33/64 D in. (52 x 48 x 64 mm).
2372-502	2-1/16 H x 1-7/8 W x 61/64 D in. (52 x 48 x 25 mm).

Accessories

Part Number	Replaces Model	Description
22-150	K502	Optional mounting bracket.
TOOL-082	—	5/64 in. hex wrench.
22-120	—	Socket.
MCS-S-P	—	Socket kit.

Typical Applications

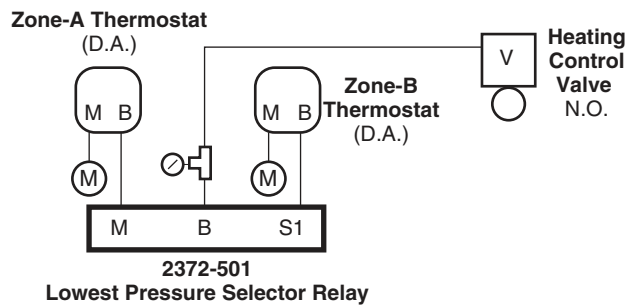

Figure 1 2372-501 Typical Application.

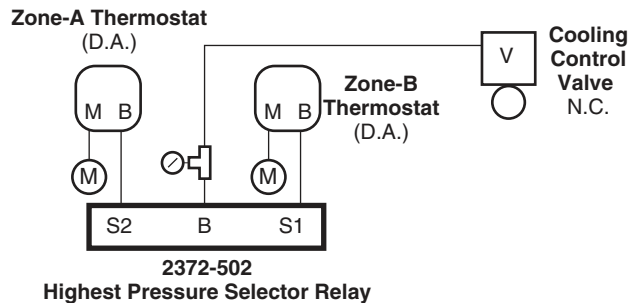

Figure 2 2372-502 Typical Application.

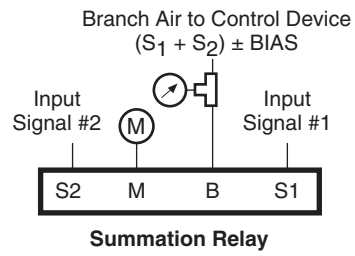

Figure 3 Typical Application.

Pneumatic Multi-Input High and Low Selector Relay

The selector relay is a device designed for use in pneumatic control systems where the application requires the comparison, selection, and transmission of the highest and/or the lowest of up to six pneumatic input signals. All input ports are “dead-ended” and no signal air passes through the relay to the output ports.

Features:

- Six-input high and low pressure selector. Requires main air connection.
- Highest of 6 inputs is output at Port H.
- Lowest of 6 inputs is output at Port L.
- Inputs numbered 1 through 6.
- All ports clearly labeled. Ports align with 22-120 socket terminals.
- Mounts on two MCS-S-P Socket Kits or on one 22-150 Mounting Bracket.

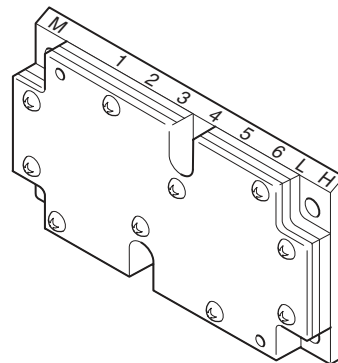

Model Chart

Model No.	Replaces Model No.	Port Connections	
		Port	Connected to
2373-501 ^a	R533	M	Main air
		L	Lowest branch output
		H	Highest branch output
		1 through 6	Input signals

^a Includes two plastic mounting straps and adhesive backed mounting plates.

Specifications

Action	Proportional.
Construction	Glass-filled nylon.
Maximum ambient temperature	140°F (60°C).
Supply air pressure	Clean, dry, oil free air required (refer to EN-123).
Nominal	20 psig (138 kPa).
Maximum	30 psig (207 kPa).
Connections	Barbed fittings for 1/4 in. O.D. polyethylene tubing.
Air consumption	43 scim (11.8 mL/s).
Air flow capacity	
HI output port	14.4 scim (3.9 mL/s).
LO output port	28.8 scim (7.8 mL/s).
Adjustments	None.
Mounting	Designed for use on two MCS-S-P Socket Kits. This device can also be mounted by using the optional 22-150 mounting bracket.
Dimensions	2 H x 4 W x 1-17/64 D in. (51 x 102 x 32 mm).

Accessories

Part Number	Replace Model	Description
22-150	K502	Optional mounting bracket.
22-120	—	Socket.
MCS-S-P	—	Socket kit.

Typical Applications

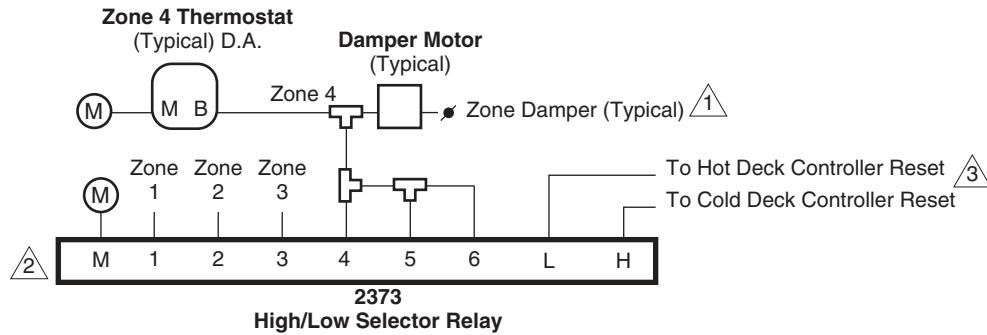

- △1 Hot Deck: N.O.
Cold Deck: N.C.
- △2 If all 6 inputs are not used, and if the low (L) output is used, connect the last used input to the remaining unused inputs. This keeps the low (L) output from reading "zero".
If only the high (H) output is used, it is not necessary to connect the unused inputs.
- △3 If either output (L or H) must operate valve or damper actuators, use a 2372-501 volume-booster relay to increase air capacity for that output on a 1:1 basis.

Figure 1 Typical Application.

Control Panel Enclosures and Devices

Air Motion Relay

This relay is used to sense suction and/or discharge pressures across a coil or fan and control pneumatic damper actuators or valves piped downstream from this device. Using sensing lines located at a fan suction and discharge and piped to the low and high ports of this relay, this device is able to detect whether or not a fan is operating. This same operation can also be detected by using one port as a reference port and piping the other port to the fan suction or discharge providing there is a differential pressure of at least 0.15 in. W.C.

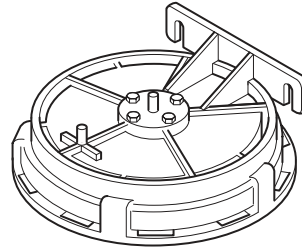

Features:

- Useful for proving fan-operation pneumatically, without the use of electrical devices.
- Originally designed for use with Unit-Ventilators, the 2374-401 may be used to operate diverting relays (such as the 2354 Series) for Air-Handling Unit Control Systems.

Model Chart

Model No.	Replaces Model No.	Description
2374-401	R435	Air Motion Relay.

Specifications

Pressure output	3 to 15 psig (21 to 103 kPa).
Pressure input	Minimum 0.15 in. W.C.(373 Pa) differential.
Environment	
Maximum ambient temperature	140°F (60°C).
Locations	Avoid areas with excessive vibration or corrosive materials.
Supply air pressure	
Nominal	20 psig (103 kPa).
Maximum	30 psig (207 kPa).
Connections	
LO/Hi Ports	3/8 in. O.D. plastic tubing.
Signal	1/4 in. O.D. plastic tubing.
Maximum static pressure	12 in. W.C. (2988 Pa).
Main air consumption	27.6 scim (7.5 mL/s).
Air capacity	48 scim. (13.1 mL/s).
Mounting	Transmitter must be mounted in a horizontal position with the correct side up.
Dimensions	5-9/16 H x 5-5/16 W x 2-11/16 D in. (141 x 135 x 69 mm).
Weight	0.5 lb. (227 g).

Accessories

Part Number	Replaces Model	Description
AP-302	—	Static pressure tip — 1/4 in. O.D. tubing.

Typical Applications

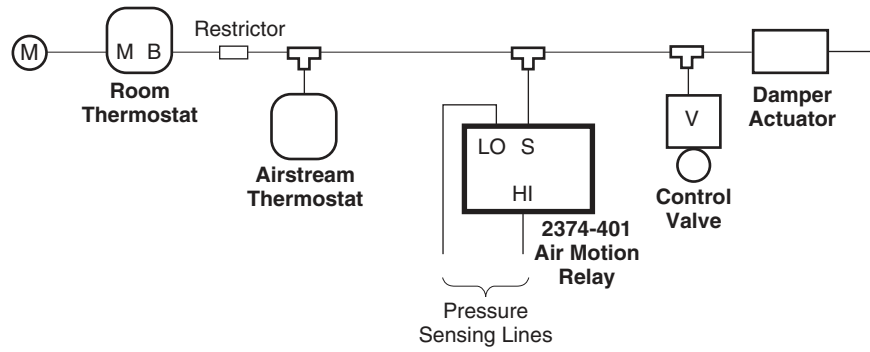

Figure 1 Typical Unit Ventilator Control Application.

Pneumatic Averaging Relay

The averaging relay is a proportional device designed for use in pneumatic control systems where the application requires operation of a final control device, or some other control action such as resetting a receiver controller, by the average of the signals from two pneumatic devices. The relay also amplifies the volume of air available to the control device, thereby minimizing system lag.

Features:

- Averaging relay (with adjustable bias, factory set to zero). Output equals the sum of the two inputs (S-1 and S-2), divided by two.
- Unlike some competitive bleed-type “averaging relays” (accurate only when the two inputs are equal, and whose accuracy decreases as the square of the signal difference), the 2376-501 is a true averaging relay.
- All ports are clearly labeled. Ports align with 22-120 socket terminals.
- Mounts on MCS-S-P Socket Kit or 22-150 Mounting Bracket.

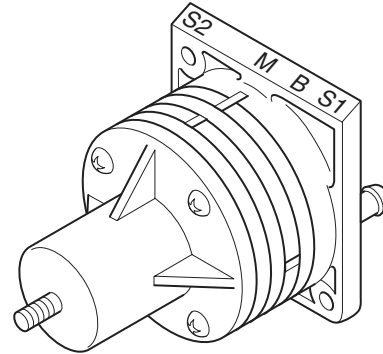

Model Chart

Model No.	Replaces Model No.	Port Connections	
		Port	Connected to
2376-501 ^a	R540	M	Main air
		B	Branch output
		S ₁	Input signal no. 1
		S ₂	Input signal no. 2

^a Includes plastic mounting strap and adhesive backed mounting plate.

Specifications

Action	Proportional.
Construction	Glass-filled nylon.
Maximum ambient temperature	140°F (60°C).
Supply air pressure	Clean, dry, oil free air required (refer to EN-123).
Nominal	20 psig (138 kPa).
Maximum	30 psig (207 kPa).
Connections	Barbed fittings for 1/4 in. O.D. polyethylene tubing.
Air consumption	28.8 scim (7.9 mL/s).
Air flow capacity	230.4 scim (62.9 mL/s).
Adjustments	Output may be advanced or retarded ±10 psig (69 kPa) by means of TOOL-082 (5/64 in. hexhead wrench).
Mounting	Designed for use on MCS-S-P Socket Kit. This device can also be mounted by using the optional 22-150 mounting bracket.
Dimensions	2-1/16 H x 1-7/8 W x 2-33/64 D in. (52 x 48 x 64 mm).

Accessories

Part Number	Replaces Model	Description
22-150	K502	Mounting bracket.
TOOL-082	—	5/64 in. hexhead wrench.
22-120	—	Socket.
MCS-S-P	—	Socket Kit.

Typical Applications

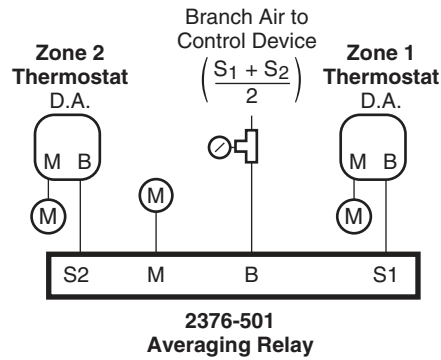

Figure 1 Typical Application.

Control Panel Enclosures and Devices

Pneumatic 2:1 Ratio Amplifying Relay

The amplifying relay is a proportional device designed for use in pneumatic control systems where the application requires the amplification of a proportional signal from a controlling device. The relay's branch line pressure output increases as a 2:1 ratio to the input signal pressure (up to main air pressure) and amplifies the volume of air available to the final control device, thereby minimizing system lag.

Features:

- 2:1 signal amplifying relay, with adjustable bias. Output changes are equal to input changes multiplied by two.
- Ideal for applications such as:
 - Operating two actuators that have the same spring range in sequence (using two 2378-501s and their bias adjustments).
 - Narrowing the throttling range of any pneumatic controller (or portion of an operating sequence) by a factor of two.
 - Factory set for 10 psig (69 kPa) branch pressure at 5 psig (34.5 kPa) input pressure at port S₁.
- All ports clearly labeled. Ports align with 22-120 socket terminals.
- Mounts on 22-120 socket or 22-150 mounting bracket.

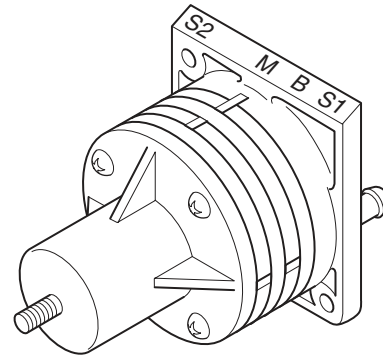

Model Chart

Model No.	Replaces Model No.	Port Connections	
		Port	Connected to
2378-501 ^a	R539	M	Main air
		B	Branch output
		S ₁	Input signal

^a Includes plastic mounting strap and adhesive backed mounting plate.

Specifications

Action	Proportional output at 2:1 ratio.
Construction	Glass-filled nylon.
Maximum ambient temperature	140°F (60°C).
Supply air pressure	Clean, dry, oil free air required (refer to EN-123).
Nominal	20 psig (138 kPa).
Maximum	30 psig (207 kPa).
Connections	Barbed fittings for 1/4 in. O.D. polyethylene tubing.
Air consumption	28.8 scim (7.9 mL/s).
Air flow capacity	230.4 scim (62.9 mL/s).
Adjustments	Bias can be manually adjusted from +5 to -13 psig by means of TOOL-082 (5/64 in. hexhead wrench).
Mounting	Designed for use on 22-120 socket. This device can also be mounted by using the optional 22-150 mounting bracket.
Dimensions	2-1/16 H x 1-7/8 W x 2-33/64 D in. (52 x 48 x 64 mm).

Accessories

Part Number	Replaces Model	Description
22-150	K502	Mounting bracket.
TOOL-082	—	5/64 in. hexhead wrench.
22-120	—	Socket.
MCS-S-P	—	Socket kit.

Typical Applications

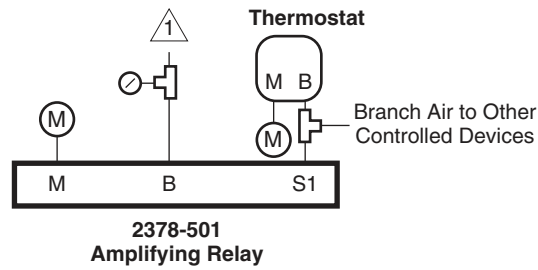

Branch (output) air to portion of control system requiring pressure changes at twice the rate of thermostat output pressure change.

Figure 1 Typical Application.

Pneumatic Signal Repeating Relay

The signal repeating relay is a proportional device for use in pneumatic control systems where it is desirable to repeat a pneumatic signal accurately, such as the output signal from a pneumatic transmitter which must be transmitted to receiver controllers or indicators at multiple locations. In addition to accurately repeating the input signal, use of the relay minimizes transmission lag by increasing the volume of signal air to devices located remotely from transmitter (see Figure 1).

This device may also be used as a signal blocking relay and as a signal limiting relay.

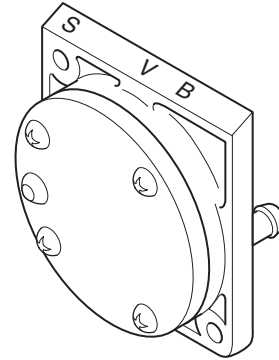

Features:

- Signal-repeating relay; repeats transmitter signal to multiple pneumatic devices at remote locations. Non-adjustable.
- May be used for signal-blocking applications.
- May be used with two adjustable restrictors as High/Low Signal-Limiting Relay.
- All ports clearly labeled. Ports align with 22-120 socket terminals.
- Mounts on MCS-S-P Socket Kit or 22-150 mounting bracket.

Model Chart

Model No.	Replaces Model No.	Port Connections	
		Port	Connected to
2379-501	R534	S	Input signal
		B	Branch output
		V	Vent

Specifications

Operation

Signal repeating application	Restricted main air at port B will accurately track the input pressure at port S.
Blocking application	With no air pressure applied at port S, ports V and B are connected. With air pressure at port S, ports V and B are blocked.
Construction	Glass-filled nylon.
Maximum ambient temperature	140°F (60°C).
Supply air pressure	Clean, dry, oil free air required (refer to EN-123).
Nominal	20 psig (138 kPa).
Maximum	30 psig (207 kPa).
Connections	Barbed fittings for 1/4 in. O.D. polyethylene or 5/32 in. I.D. polyurethane tubing.
Air consumption	1728 scim (7.9 mL/s).
Air flow capacity	1728 scim (7.9 mL/s).
Adjustments	Non-adjustable.
Mounting	Designed for use on 22-120 socket. This device can also be mounted by using the 22-150 mounting bracket.
Dimensions	2-1/16 H x 1-7/8 W x 61/64 D in. (52 x 48 x 24 mm).

Accessories

Part Number	Replaces Model	Description
22-150	K502	Mounting bracket.
21-153	N100-2501	28.8 scim restrictor.
20-802	N100-46	Adjustable restrictor.
21-038	N100-0010	Restrictor tee, polyethylene tubing.
22-120	—	Socket.
MCS-S-P	—	Socket kit.

Typical Applications

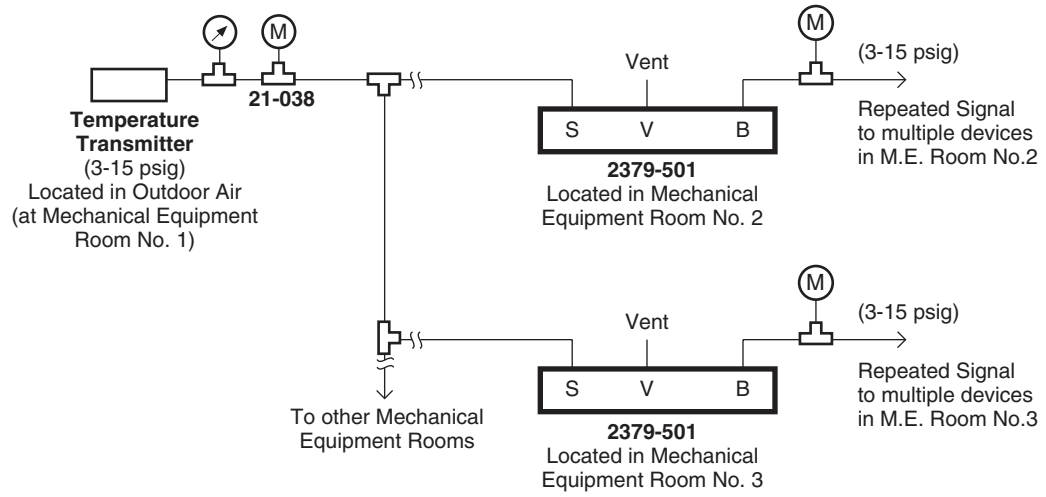
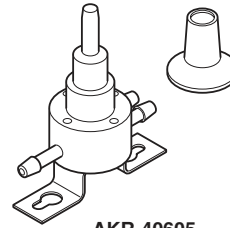

Figure 1 Typical Application.

Control Panel Enclosures
and Devices

Limiting, 1:1 Ratio Relay

Pneumatic 1:1 ratio direct acting relay is used to limit minimum or maximum output pressure. The AKR-40605 can also be used as a manual positioner, 1:1 ratio relay, or lowest of two pressures selector. Relay will also increase the capacity of a controller (except when used as maximum output limiter or lowest pressure selector).



AKR-40605

Model Chart

Model No.	Description	Output	Air Connection Code		
			Port P	Port B ^a	Port M
AKR-40605	Minimum output limiting	Minimum output adjustable 0 to 20 psig (0 to 138 kPa)	Pilot	Output	Main
	Maximum output limiting	Maximum output adjustable 0 to 20 psig (0 to 138 kPa)	Open to atmosphere		Input
	Manual positioner	Manually selected from 0 to 20 psig (0 to 138 kPa)			Main
	1:1 Ratio relay	0 to 20 psig (0 to 138 kPa)	Pilot		Input
	Lowest pressure selector	Lowest of two pressures 0 to 20 psig (0 to 138 kPa)	Input		Input

^a Output pressure will drop to 0 when main air supply is reduced to 0. The reduced air pressure allows controlled device(s) to return to an ensured safe condition when main air pressure to the AKR-40605 is relieved.

Specifications

Action	1:1 direct.
Output	Refer to Model Chart.
Construction	
Housing	Polysulfone.
Diaphragm	Neoprene.
Adjustments	Refer to Model Chart for outputs.
Air pressure	
Maximum	30 psig (207 kPa).
Nominal supply	15 to 25 psig (103 to 138 kPa).
Ambient limits	
Shipping and storage	-40 to 160°F (-40 to 71°C).
Operating	32 to 140°F (0 to 60°C).
Humidity	5 to 95% RH, non-condensing.
Air connection code	Refer to Model Chart.
Air connections	Barbed for 1/4 in. O.D. plastic tubing.
Air consumption for sizing air compressor	3.5 scim (0.9 mL/s).
Air capacity for sizing air mains	16 scim (4.4 mL/s).
Mounting	Panel, wall or in-line; mounting plate and two push-in fasteners for perforated metal subpanel provided.
Panel space required	4 H x 2-7/16 W x 1-3/4 D in. (102 x 62 x 44 mm).

Typical Applications

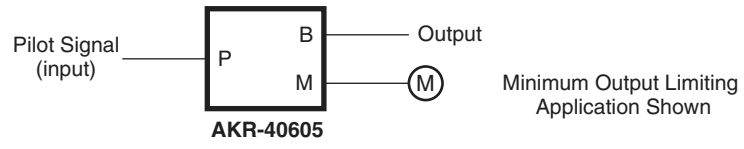
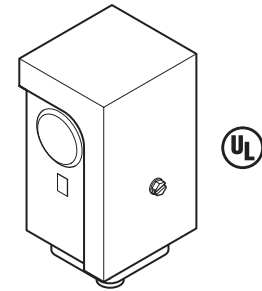

Figure 1 Piping Connections.

Pneumatic-Electric Switches

The pneumatic-electric switches are used in control systems requiring conversion of gradual air pressure changes to positive electrical switching actions. The 2364-211 has one SPDT switch for switching a single circuit. The 2364-220 has two SPDT switches for switching two separate circuits simultaneously.



Features:

- Fixed-differential P.E. switches permit two-position electrical switching action from either modulating or two-position pneumatic signals.
- High current rating: 20 amps non-inductive, 120, 240, 480Vac.
- 2364-211 has one SPDT switch.
- 2364-220 has two SPDT switches which operate simultaneously.
- May be wall-mounted or panel-mounted where necessary to keep wiring runs short.

Control Panel Enclosures and Devices

Model Chart		
Model No.	Replaces Model No.	Description
2364-211	R471-1	Pneumatic-electric relay with (1) SPDT switch.
2364-220	R472-1	Pneumatic-electric relay with (2) SPDT switches.

Specifications	
Environment	
Ambient temperature limits	32 to 140°F (0 to 60°C).
Relative humidity limits	5 to 95% RH, non-condensing. Avoid areas with excessive vibration or corrosive materials.
Location	NEMA 1.
Maximum safe pressure	30 psig (206.8 kPa). Clean, dry control air only.
Connections	
Air	3/16 in. (4.76 mm) nipple for 1/4 in. (6.35 mm) O.D. tubing.
Wiring	Screw terminals. 1/2 in. conduit openings on both sides of housing.
Setpoint	
2364-211	2 to 25 psig (13.8 to 172.4 kPa). Differential 2.0 psi (13.8 kPa) nominal, fixed.
2364-220	4 to 20 psig (27.6 to 137.8 kPa). Differential 2.5 to 3.0 psi (17.2 to 20.7 kPa) nominal, fixed.
Switch action	SPDT
Switch rating (each switch)	20 amps non-inductive at 120-240-480 Vac. 1 hp at 125 Vac, 2 hp at 240 Vac.
Mounting	Relay may be mounted in any position.
Dimensions	3-11/16 H x 2-1/2 W x 2-7/16 D in. (94 x 64 x 62 mm).

Accessories		
Part Number	Replaces Model	Description
Maintenance Parts 20-684	6-532	Diaphragm.

Typical Applications

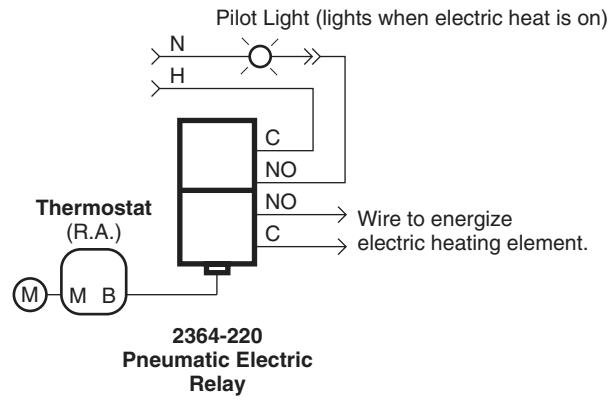
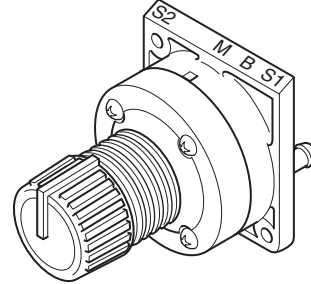

Figure 1 Typical Application (2364-220 shown).

Pneumatic Gradual Switches

The 2390 gradual switch is designed to allow manual setting of a desired pressure, up to main air pressure, where the application requires remote positioning of final control devices or remote control point adjustment of a pressure signal is desired.

The 2390-505 and 2390-510 have been designed with an internal high pressure selector relay, primarily for use as a minimum position switch for damper operation when used with actuators having a 5 or 10 psig (34.5 or 69 kPa) span, respectively.



Features:

2390 Gradual and Minimum-Position Switches can easily be mounted any of three ways:

- Flush-mounted on panel face. Dial plate locks onto switch body and is held in place by tightening the mounting nut from the rear. Provides exposed adjustment.
- Mounted with two screws and 22-133 gasket to MCS-S-P Socket Kit. Provides concealed adjustment.
- Mount using the 22-155 mounting bracket.
- All ports clearly labeled. Ports align with 22-120 socket terminals.

Model Chart					
Model No.	Replaces Model No.	Function	Comments	Active Connections	
				Port	Connected to
2390-501	S510	Gradual switch	0 to 20 psig (0 to 138 kPa) output	M B	Main Branch
2390-505	S511-5	Minimum position switch	5 psig (34.5 kPa) span output		
2390-510	S511-10	Minimum position switch	10 psig (69 kPa) span output		

Specifications	
Action	Proportional.
Construction	
Case	Glass-filled nylon.
Dial plates	Anodized aluminum.
Knob	Black sunburst plastic.
Maximum ambient temperature	140°F (60°C).
Supply air pressure	Clean, dry, oil free air required (refer to EN-123).
Nominal	20 to 25 psig (138 to 172 kPa).
Maximum	30 psig (207 kPa).

Specifications (Continued)

Connections	Barbed fittings for 1/4 in. O.D. polyethylene tubing.
Air consumption	28.8 scim (7.9 mL/s).
Air capacity	230.4 scim (62.9 mL/s).
Mounting	Designed for use on MCS-S-P Socket Kit. These devices can also be mounted on a panel face or surface mounted by using the appropriate mounting bracket (refer to Accessories).
Dimensions	
2390-501	2-1/16 H x 1-7/8 W x 3-1/4 D in. (52 x 48 x 83 mm).
2390-505, 2390-510	2-1/16 H x 1-7/8 W x 3-1/2 D in. (52 x 48 x 89 mm).

Accessories

Part Number	Replaces Model	Description
TOOL-082	—	5/64 in. hexhead wrench.
22-155	K511	Single switch bracket.
22-120	—	Socket.
MCS-S-P	—	Socket kit.
Maintenance Parts		
22-173	—	Switch knob.

Typical Applications

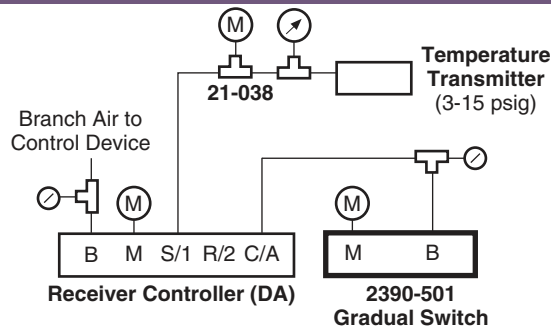

Figure 1 2390-501 Typical Application.

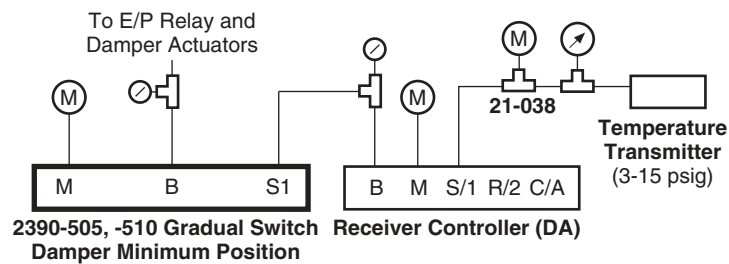

Figure 2 2390-505, -510 Series Typical Application.

Control Panel Enclosures and Devices

Pneumatic Two- and Three-Position Selector Switches

These switches are manually operated devices adaptable to a wide variety of applications in pneumatic control systems. They are normally used to perform diverting or supply and exhaust functions to operate final control components or index relays in multiple switching systems.

The 2392-504 is a two-position, four-branch switch. The 2392-505 is a two-position five-branch switch that provides one blocked port in each knob position.

The 2393-504 is a three-position, four-branch switch which can be used to supply a signal to any one of three devices or supply any one of three signals to a device. Its unused ports are blocked.

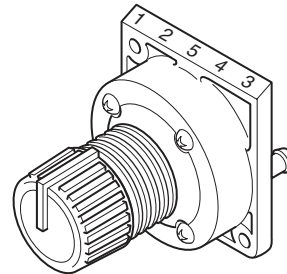

Features:

239x-50x Series Selector Switches can easily be mounted any of three ways:

- Flush-mounted on panel face. Dial plate locks onto switch body and is held in place by tightening the mounting nut from the rear. Provides exposed adjustment.
- Mounted with two screws and 22-133 gasket to MCS-S-P Socket Kit. Provides concealed adjustment.
- Mount using the 22-155 bracket.
- All parts clearly labeled. Ports align with 22-120 socket terminals.

Model Chart		
Model No.	Replaces Model No.	Description
2392-504	S520	Two-position, four-branch.
2392-505 ^a	S521	Two-position, five-branch (one blocked port in each knob position).
2393-505	S530 and S531	Three-position, four-branch (unused ports exhausted).

^a If required, unused ports may be plugged

Specifications

Construction	
Case	Glass-filled nylon.
Dial plates	Anodized aluminum.
Knob	Black sunburst plastic with pointer.
Maximum ambient temperature	140°F (60°C).
Supply air pressure	Clean, dry, oil free air required (refer to EN-123).
Maximum	30 psig (207 kPa).
Connections	Barbed fittings for 1/4 in. O.D. polyethylene tubing.
Air consumption	None.
Air flow capacity	1,152 scim (314.5 mL/s).
Adjustments	Knob.
Mounting	Designed for use on MCS-S-P Socket Kit. These devices can also be mounted on a panel face or surface mounted by using the appropriate mounting bracket (refer to Accessories).
Dimensions	2-1/16 H x 1-7/8 W x 2-7/8 D in. (52 x 48 x 73 mm).

Accessories

Part Number	Replaces Model	Description
22-155	K511	Single switch bracket.
22-120	—	Socket.
MCS-S-P	—	Socket kit.
Maintenance		
22-173	—	Switch knob.

Typical Applications

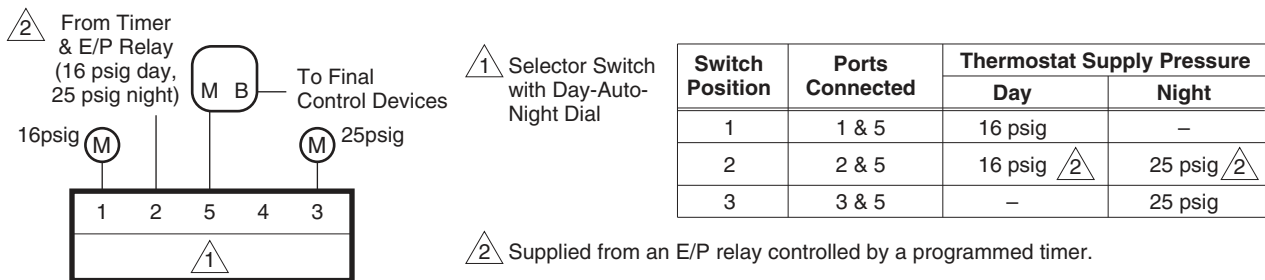

Figure 1 Automatic or Manual Changeover of Day/Night System.

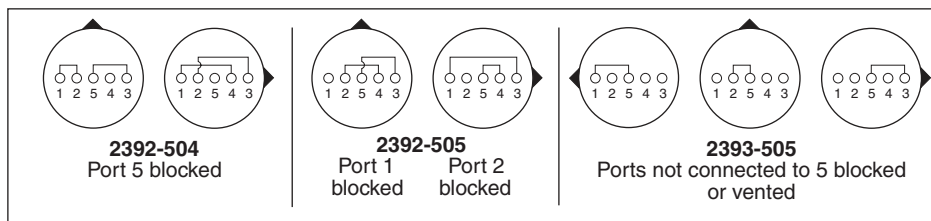

Figure 2 Internal Port Connections.

Control Panel Enclosures and Devices

Pneumatic Pressure Regulator

The 2390-515 pressure regulator allows the manual setting of any desired air pressure, up to main pressure, where the application requires remote positioning of final control devices, remote control point adjustment of receiver controllers, or any other application where manual setting of an output pressure is desired.

Features:

- Pressure regulator allows any desired pressure (up to main air pressure) to be set with a 5/64 in. hex wrench TOOL-082.
- Mounts on MCS-S-P Socket Kit or 22-150 Mounting Bracket.
- All ports clearly labeled. Ports align with 22-120 socket terminals.

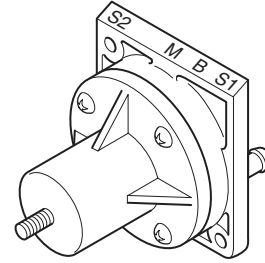

Model Chart					
Model No.	Replaces Model No.	Function	Comments	Active Connections	
				Port	Connected to
2390-515	S515	Pressure regulator	0 to main air pressure output	M	Main
				B	Branch

Specifications	
Action	Proportional.
Construction	
Case	Glass-filled nylon.
Maximum ambient temperature	140°F (60°C).
Supply air pressure	Clean, dry, oil free air required (refer to EN-123).
Nominal	20 to 25 psig (138 to 172 kPa).
Maximum	30 psig (207 kPa).
Connections	Barbed fittings for 1/4 in. O.D. polyethylene tubing.
Air consumption	28.8 scim (7.9 mL/s).
Air capacity	230.4 scim (62.9 mL/s).
Mounting	Designed for use on MCS-S-P Socket Kit. These devices can also be mounted on a panel face or surface mounted by using the appropriate mounting bracket (refer to Accessories).
Dimensions	2-1/16 H x 1-7/8 W x 1-61/64 D in. (52 x 48 x 50 mm).

Accessories		
Part Number	Replaces Model	Description
21-038	N100-0010	Restrictor tee for polyethylene tubing.
TOOL-082	—	5/64 in. hexhead wrench.
22-120	—	Socket.
MCS-S-P	—	Socket kit.
Mounting Bracket		
22-150	K502	Mounting bracket.
Maintenance Parts		
22-173	—	Switch knob.

Typical Applications

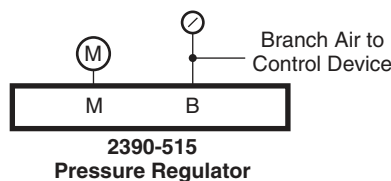
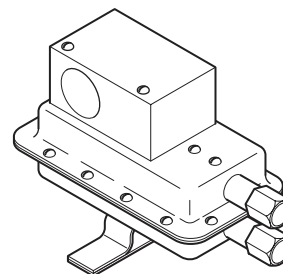

Figure 1 Typical Application.

Air Differential Pressure Switch

The AFS Series differential pressure switch are sensitive and reliable devices for remotely sensing the operation of fans or blowers associated with ducted ventilating systems, and for sensing static pressure drop across filters. Pressure differentials as small as 0.05 in. WC are sufficient to actuate the SPDT contacts, which in turn operate remote status indicators, alarms, or control circuits of other devices.



AFS-222 Shown

Features:

- Differential setpoint adjustable from 0.05 to 12 in. WC to suit various applications.
- The AFS-222 and AFS-222-112 are field adjustable over a wide range of pressures, and are relatively insensitive to temperature extremes. They are recommended for any differential pressure application within their operating ranges.

Model Chart		
Model No.	Replaces Model No.	Description
AFS-222	R436 and 2374-410	Air pressure switch with adjustable setpoint.
AFS-222-112	—	
AFS-262	—	
AFS-460	—	Air pressure switch with manual reset.

Specifications

Setpoint	
AFS-222 and AFS-222-112	Field adjustable 0.05 ±0.02 to 12 in. WC.
AFS-262	Field adjustable 0.05 ±0.02 to 2 in. WC.
AFS-460	Field adjustable 0.40 ±0.06 to 12 in. WC.
Differential	
AFS-222 and AFS-222-112	Progressive, increasing from 0.02 in. ±0.01 in. WC at minimum set point to approximately 0.8 in. WC at maximum set point.
AFS-262	Progressive, increasing from 0.02 in. ±0.01 in. WC at minimum set point to approximately 0.1 in. WC at maximum set point.
AFS-460	Progressive, increasing from 0.06 in. ±0.01 in. WC at minimum set point to approximately 0.8 in. WC at maximum set point.
Electrical switch	
AFS-222, AFS-222-112, AFS-262	SPDT, 300 VA pilot duty at 115 to 277 Vac; 15A non-inductive to 277 Vac @ 60Hz.
AFS-460	SPST-NC, 15A 125, 250, or 277 Vac. @ 60 Hz.
Connections	Screw terminals with cup washers.
Sampling line connections:	
AFS-222, AFS-262, AFS-460	Connectors accept 1/4 in. O.D. rigid or semi-rigid tubing.
AFS-222-112	Two barbed 1/4 in. connectors will accept flexible tubing.
Mounting	Diaphragm vertical.
Conduit opening	7/8 in. diameter for 1/2 in. conduit.

Control Panel Enclosures and Devices

AFS Series

Specifications (Continued)

Operating temperature limits	-40 to 180°F (-40 to 82°C).
Dimensions	6-1/8 H x 3-7/8 W x 3-1/4 D in. (156 x 98 x 83 mm).
AFS-222, AFS-222-112, AFS-262	6-9/64 H x 3-7/8 W x 3-1/4 D in. (156 x 98 x 82 mm).
AFS-460	6-9/64 H x 3-1/4 W x 3-9/16 D in. (156 x 82 x 90mm).
Locations	NEMA 1.
Agency Approval	
AFS-222 and AFS-222-112	UL, FM, CSA.
AFS-262	UL, FM, CSA, CE.
AFS-460	UL, FM, CE.

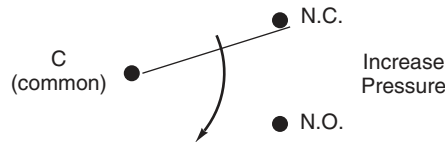

Figure 1 Switch Action and Terminal Identification.

Control Panel Enclosures and Devices

Accessories

Part Number	Replaces Model	Description
AP-302	—	Static pressure sensing tip for 1/4 in. O.D. tubing.

Typical Applications

Diaphragm Connections

Refer to figure below. For positive pressure only, connect sampling line to port E; port F remains open to atmosphere.

For negative pressure only, connect sample line to port F; port E remains open to the atmosphere.

Two positive samples; connect higher pressure to port E and lower pressure to port F.

Two negative samples; connect more negative sample to port E; less negative to port F.

One positive and one negative; positive to port E; negative to port F.

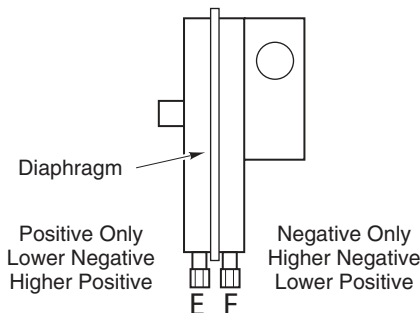

Electrical

Before any pressure is applied to the diaphragm, the switch contact rests in the N.C. position (see figure below). Upon application of sufficient pressure to actuate the switch, the contact transfers to the N.O. position. Connect control, status, and/or alarm circuits, as shown.

To prove excessive air flow or pressure

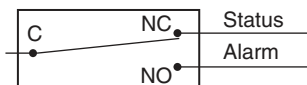

To prove insufficient air flow or pressure



Figure 2 Typical Applications.

Pneumatic to Electric Pressure Switches, Two-Position

For on-off control of electrical devices such as air compressors, fans, pilot lights, etc., by the use of a predetermined air pressure signal.

Features:

- A variety of Pressure-to-Electric (P.E.) Switches permits two-position electrical switching from either modulating or two-position pneumatic signals.
- Models are available with either fixed or adjustable differentials and with several different switch actions, permitting selection of the best model for almost any required application.
- May be wall-mounted or panel-mounted where necessary to keep wiring runs short.

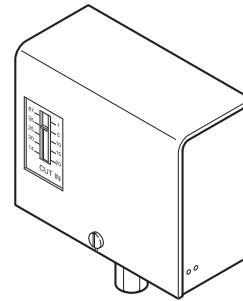

PC-110 shown



†PC-110 only CSA certified

Model Chart									
Model No.	Mounting	Switch Action	Scale Range psig (kPa)		Differential psig (kPa)		Ambient Temp. Limits °F (°C)	Max. Input psig (kPa)	Dimensions in. (mm) H x W x D
PC-110	Surface or track	SPDT makes N.O. contact to common on pressure increase	1 to 20 (7 to 138)		1 to 5 (7 to 34) adjustable factory set at 2 (14)		-40 to 150 (-40 to 118)	50 (345)	3-1/2 x 3-1/8 x 2-1/8 (89 x 79 x 54)
PC-151	Surface	3 SPST opens on pressure rise	Sw.	Open	Sw.	Fixed	32 to 140 (0 to 78)	150 (1034)	3-1/4 x 5-3/8 x 3-1/2 (83 x 137 x 89)
			1	6 (41)	1	3 (21)			
			2 and 3	18 (124)	2 and 3	0.5 (3)			

Specifications

Case	Metal with 1/2 in. conduit opening.
Diaphragm	Non-metallic, positioned by air pressure changes to actuate switches.
Connections	
Air	1/8 in. FNPT.
Electrical	Coded screw terminals.
Electrical Ratings	Refer to Electrical Ratings Table.
Location	NEMA 1.

Electrical Ratings.

Model No.	Volts (Vac)	FLA Amps	LRA Amps	Non-Ind. Amps	Pilot Duty VA
PC-110	24	—	—	16	100
	120	13.8	82.8	16	650
	208	9.6	57.6	9.6	750
	240	8.3	49.8	8.3	750
	277	—	—	7.2	—
PC-151	120	6	36	10	125 at 24/277 Vac
	208/240	3	18	8	
	277	—	—	7.2	

Control Panel Enclosures and Devices

Receiver Controller Setpoint Adjuster

Setpoint adjuster used to provide remote setpoint adjustment for receiver-controllers. May also be used to manually pilot pneumatic relays.

Features:

- Allows the setpoint of a pneumatic receiver-controller to be raised or lowered from a location up to 1000 ft. (305 m) from the receiver-controller.
- Able to work with various transmitter ranges.

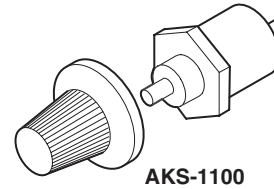

Control Panel Enclosures and Devices

Model Chart	
Model No.	Description
AKS-1100	Remote setpoint adjuster.

Specifications	
Construction	Aluminum housing, precision flapper-nozzle assembly.
Output	Linear 3 to 15 psig (21 to 102 kPa).
Air pressure	Clean, oil free, dry air required (refer to EN-123).
Maximum	30 psig (207 kPa).
Ambient limits	
Shipping temperatures	-40 to 150°F (-40 to 65°C).
Operating temperatures	40 to 120°F (4 to 49°C).
Humidity	5 to 95% RH, non-condensing.
Air connection	Barbed connection for 1/4 in. O.D. plastic tubing.
Air consumption for sizing air compressor	41.5 scim (11.3 mL/s).
Air capacity for sizing air mains	48 scim (13.1 mL/s).
Mounting	Panel or wall box. Panel requires 5/8 in. (16 mm) hole for mounting the remote setpoint adjuster.
Panel space required	2-3/8 H x 2-1/4 W x 2-1/2 D in. (60 x 57 x 63 mm).

Typical Applications

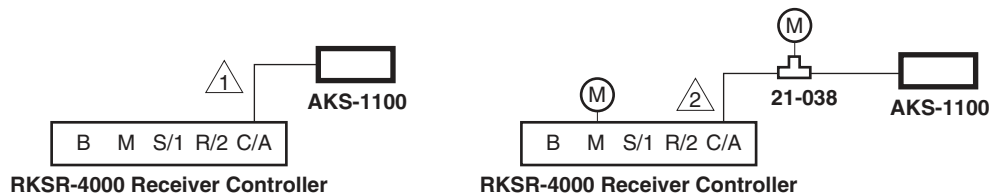

1. When internal restrictor is used, AKS-1100 must be located within 200 ft. (61 m) of receiver-controller.
2. When external restrictor is used, AKS-1100 must be located within 1000 ft. (305 m) of receiver-controller, and the restrictor must be located within 200 ft. (61 m) of the transmitter (preferably at the transmitter's location). Remove internal restrictor from receiver-controller and install blocking gasket.

Figure 1 Typical Setpoint Adjuster Application.

Thermostats

Table of Contents

2211 through 2218 Series	84
2212-318, 2212-319	89
2218-301	91
TK-1xxx, TK-5xxx Series	93
TK-17xx Series	96
TK-2xxx, TK-3xxx, TK-4xxx, TK-4212-201	99
TK-6xxx, TK-8xxx Series	101

Room Thermostats

These pneumatic room thermostats are designed for proportional temperature control of pneumatic valves and damper actuators to maintain room air temperatures in heating, ventilating, and air conditioning systems.

Features:

- Small size, approximately 2 x 2 in. (51 x 51 mm).
- Factory calibrated. Stainless steel ball-in-seat provides pneumatic feedback for linear, stable operation.
- Easy-to-use throttling range adjustment and recalibration.
- Adjustable bimetal shows actual throttling range in both °F and °C. Adjustable 2 to 12°F (1 to 6.7°C).
- Setpoint (in both °F and °C) shown on thermostat body with cover removed.
- Leakproof, O-ring sealed, spring-loaded self-closing branch gauge tap.
- 2214 and 2216:
 - Separate factory-calibrated night bimetal and setpoint dial, with fixed 4 F° (2 C°) night throttling range for accurate “night” operation.
 - Snap-acting (not gradual) changeover from “day” to “night” operation and vice versa.
- 2216:
 - Third port (R) output with manual reset lever allows full restoration of day operation (typically, of unit ventilator), with either manual or automatic reset to day-night schedule.
- 2218:
 - Snap-acting (not gradual) changeover from direct-action to reverse-action and vice versa.

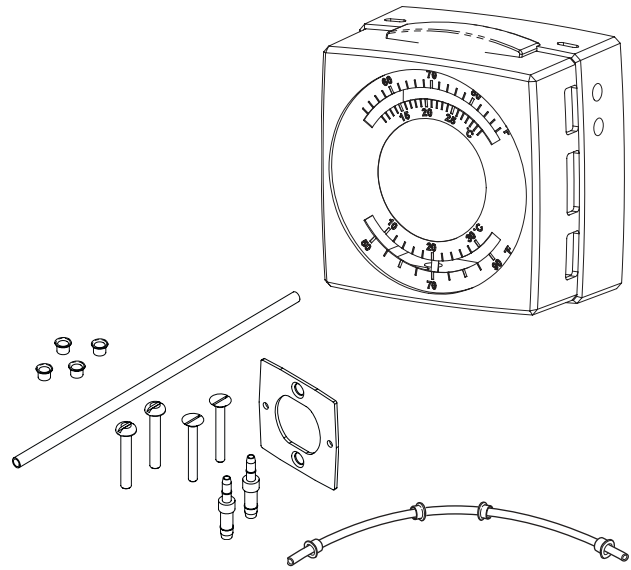

Model Chart				
Model No.	Replaces Model No.	Dial Range °F (°C)	Air Consumption	Description (Refer to Following Pages for More Detail)
2211-012	T12-301	55 to 85 (13 to 29)	0.017 scfm at 20 psig (0.48 L/m at 138 kPa)	Single temperature, one-pipe, D.A.
2211-013	T13-301			Single temperature, one-pipe, R.A.
2212-118	T18-301	55 to 85 (13 to 29)	15.6 scim at 20 psig (4.2 mL/s at 138 kPa)	Single temperature, two-pipe, D.A., throttling range adjustable 2° to 12°.
2212-119	T19-301			Single temperature, two-pipe, R.A., throttling range adjustable 2° to 12°.
2212-618	—			Single temperature, two-pipe, R.A., throttling range adjustable 2° to 12° (includes 20-023).
2212-619	—			
2214-121	T23-301	Day 55 to 85 (13 to 29)	29.4 scim at 16 psig (8.0 mL/s at 110 kPa)	Day-Night Thermostat, two-pipe, D.A. 16 psig (110 kPa) day, 25 psig (172 kPa) night.
		Night 50 to 80 (10 to 27)	43.2 scim at 25 psig (11.8 mL/s at 172 kPa)	
2214-122	T24-301	Day 55 to 85 (13 to 29)	29.4 scim at 16 psig (8.0 mL/s at 110 kPa)	Day-Night Thermostat, two-pipe, R.A. 16 psig (110 kPa) day, 25 psig (172 kPa) night.
		Night 50 to 80 (10 to 27)	43.2 scim at 25 psig (11.8 mL/s at 172 Kpa)	
2216-126	T27-301	Day 55 to 85 (13 to 29)	29.4 scim at 16 psig (8.0 mL/s at 110 kPa)	Day-Night Thermostat, three-pipe, with manual reset lever D.A. 16 psig (110 kPa) day, D.A. 25 psig (172 kPa) night.
		Night 50 to 80 (10 to 27)	43.2 scim at 25 psig (11.8 mL/s at 172 Kpa)	
2218-132	T32-301	55 to 85 (13 to 29)	31.1 scim at 16 psig (8.5 mL/s at 110 kPa)	Summer-Winter, throttling range adjustable 2° to 12°. 16 psig (110 kPa) Main — R.A., Summer. 25 psig (172 kPa) Main — D.A., Winter. (Can be used with 8 psig summer main if recalibrated in the field.)
			43.2 scim at 25 psig (11.8 mL/s at 172 Kpa)	
2218-134	T32-321		22.5 scim at 13 psig (6.1 mL/s at 90 kPa)	Summer-Winter Thermostat for use with Honeywell 13 to 18 psig Systems. 13 psig (89 kPa) Main — R.A., Summer. 18 psig (124 kPa) Main — D.A., Winter.
			34.5 scim at 18 psig (9.4 mL/s at 124 kPa)	
2218-133	T33-301		29.4 scim at 15 psig (8 mL/s at 103 kPa)	Summer-Winter Thermostat for use with Johnson main air systems. 25 psig (172 kPa) Main — R.A., Summer. 16 psig (110 kPa) Main — D.A., Winter.
			34.5 scim at 20 psig (9.4 mL/s at 138 Kpa)	

Note: Includes 1/4" by 3/16" barbed couplings, 20-693 tubing kit, 22-024 standard mounting kit, 20-928 gray plastic cover with F/C listing.

Thermostats

2211 through 2218 Series

Specifications

Action	Proportional; refer to Model Chart.
Setpoint range	55 to 85°F (13 to 29°C).
Throttling range	2 to 12°F/12 psi (1.1 to 6.7°C/83 kPa) adjustable, factory set 3°F (1.7 °C) [night, 3 to 5°F/12 psi (1.7 to 2.7°C/83 kPa), non-adjustable].
Construction	
Components	Die cast aluminum, stainless steel, and glass-filled nylon.
Diaphragms	Fabric-reinforced neoprene.
Air filter	Internal.
Supply air pressure	
Nominal	Refer to Model Chart and Typical Applications.
Maximum	30 psig (207 kPa).
Connections	For spring-reinforced 3/16 in. O.D. plastic tubing and required fittings.
Air consumption	Refer to Model Chart and Typical Applications.
Calibration point	9 psig (62 kPa) branch line pressure when ambient temperature equals setpoint (except 2218-3x1 Series and 2218-133, 12 psig branch line pressure).
Setpoint adjustment	Serrated thumbwheel, external or concealed.
Mounting	Upright position on wall.
Dimensions	2-1/32 H x 2-1/32 W x 1-3/8 D in. (52 x 52 x 35 mm).

Accessories

Part Number	Replaces Model	Description
Accessories		
20-660	6-441	Cover screw (included with thermostat).
20-707	10-53	Metal thermostat guard.
20-715	10-62	Clear thermostat guard.
21-876	10-76	Opaque thermostat guard.
21-928	—	Gray plastic cover, blank dial.
21-933	—	Gray plastic cover, °F/°C dial (included with thermostat).
21-933-1	—	Gray plastic cover, Day/Night dial.
Calibration		
20-881	N2-4	Calibration wrench.
22-138	MCS-GA	Branch tap gauge adaptor.
900-002	—	Thermostat calibration kit.
Installation		
10-82-SS	—	Outlet box mounting plate, stainless steel.
20-850	10-82	Outlet box mounting plate, black.
20-642	6-371	Mounting ring.
21-473	10-73	Snap-in drywall mounting bracket.
22-021	—	Universal drywall mounting kit.
22-022	N5-95	Competitor replacement mounting kit.
22-024	—	Standard mounting kit (included with thermostat).
22-693	—	Tubing kit (included with thermostat).
Only for 2212-118, 2212-119, 2211-012, 2211-013, 2214-121		
20-712	10-59	Dial stop kit.
Only for 2212-61x		
21-930	—	White cover.
22-023	—	Thermostat conversion kit, white.

For additional information, refer to Accessories on page 124.

Typical Applications

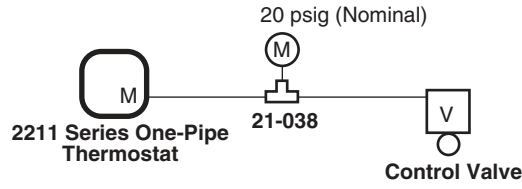

Figure 1 2211 Typical Application.

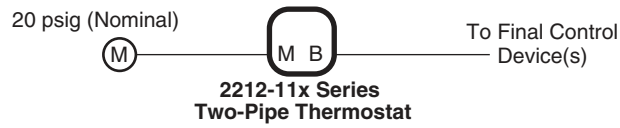

Figure 2 2212-11x Typical Application.

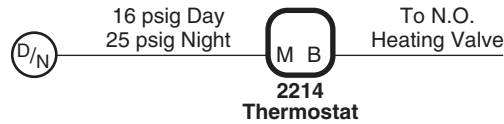

Figure 3 2214 Typical Application.

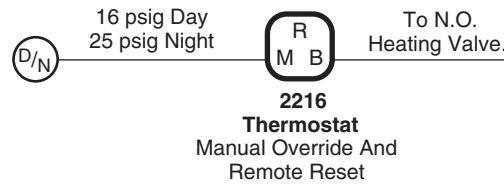

Figure 4 2216 Typical Two Pipe Application.

2211 through 2218 Series

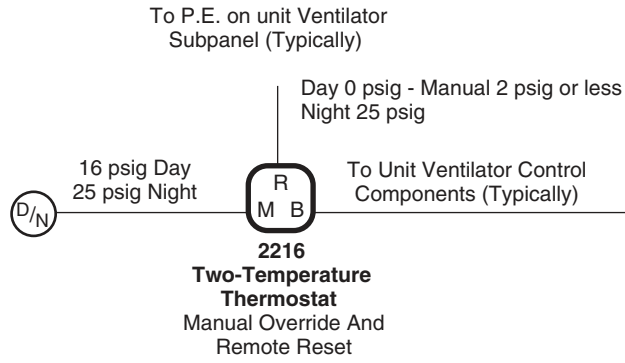

Figure 5 2216 Typical Three Pipe Application.

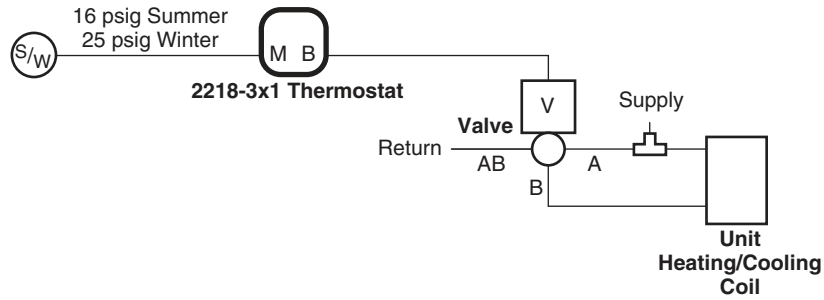

Figure 6 2218-3x1 Typical Application.

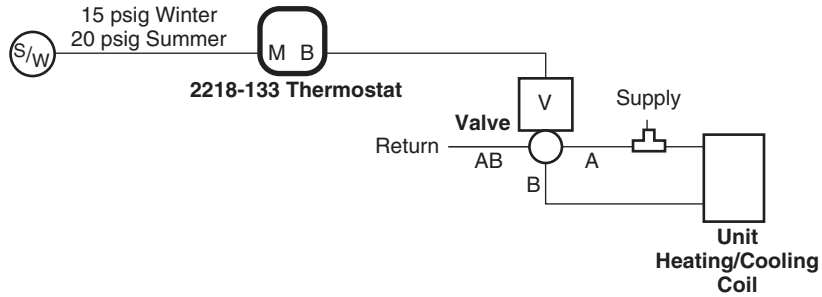

Figure 7 2218-133 Typical Application.

Dual Setpoint/Deadband Room Thermostat

The dual setpoint/deadband pneumatic room thermostats are designed for the proportional control of pneumatic valves, damper actuators, and other control devices. With this product, the HVAC system uses no energy between pre-selected heating and cooling setpoints.

Features:

- Factory calibrated. Stainless steel ball-in-seat provides pneumatic feedback for linear, stable operation.
- Deadband is set by setting desired heating and cooling setpoints.
- Deadband output pressure factory set at 8 psig (55 kPa); field adjustable.
- Leakproof, O-Ring-sealed, spring-loaded self-closing branch gauge tap.

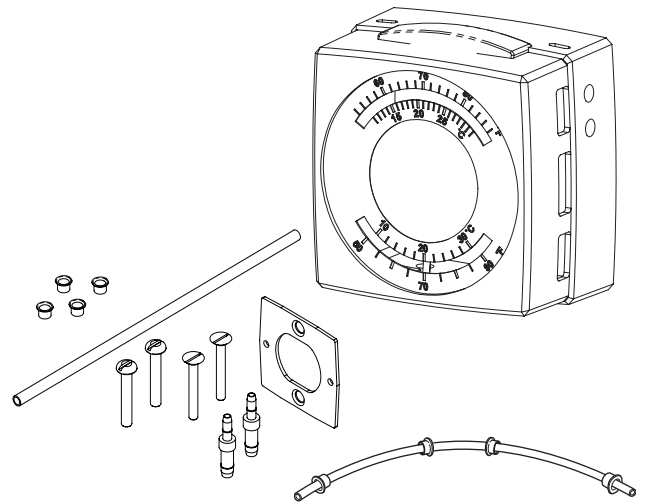

Model Chart

Model No.	Replaces Model No.	Description
2212-318	T35-301	Refer to Specifications.
2212-319	T36-301	

Note: Includes 1/4" by 3/16" barbed couplings, 20-693 tubing kit, 22-024 standard mounting kit, 20-928 gray plastic cover with F/C listing.

Specifications

Action	Proportional, with deadband.
2212-318	Direct.
2212-319	Reverse.
Setpoint range	
Heating	57 to 75°F (14 to 24°C).
Cooling	65 to 83°F (18 to 28°C).
Throttling range	Approximately 1.5°F/5 psi (0.8°C/0.7 kPa) for each setpoint non-adjustable.

Specifications (Continued)

Construction	
Components	Die cast aluminum, stainless steel, and glass-filled nylon.
Diaphragms	Fabric-reinforced neoprene.
Air filter	Internal.
Supply air pressure	
Operating	20 psig (138 kPa).
Maximum	30 psig (207 kPa).
Connections	
For spring-reinforced 3/16 in. plastic tubing and required fittings (included).	
Air consumption	
29.4 scim at 20 psig (8.0 mL/s at 138 kPa) main air pressure.	
Calibration point	
Deadband output	Factory set at 8 psig (adjustable).
Direct acting 2212-318	Heating: 4 psig (28 kPa) at setpoint. Cooling: 10.5 psig (72 kPa) at setpoint.
Reverse acting 2212-319	Cooling: 4 psig (28 kPa) at setpoint. Heating: 10.5 psig (72 kPa) at setpoint.
Setpoint adjustment	
Individual concealed adjustments or heating and cooling by means of 20-881 calibration tool.	
Mounting	
Upright position on wall.	
Dimensions	
2-1/32 H x 2-1/32 W x 1-3/8 D in. (52 x 52 x 35 mm).	

Accessories

Part Number	Replaces Model	Description
Accessories		
20-660	6-441	Cover screw (included with thermostat).
20-707	10-53	Metal thermostat guard.
20-715	10-62	Clear thermostat guard.
21-876	10-76	Opaque thermostat guard.
21-928	—	Gray plastic cover, blank dial.
21-933	—	Gray plastic cover, °F/°C dial (included with thermostat).
21-933-1	—	Gray plastic cover, Day/Night dial.
Calibration		
20-881	N2-4	Calibration wrench.
22-138	MCS-GA	Branch tap gauge adaptor.
900-002	—	Thermostat calibration kit.
Installation		
10-82-SS	—	Outlet box mounting plate, stainless steel.
20-850	10-82	Outlet box mounting plate, black.
20-642	6-371	Mounting ring.
21-473	10-73	Snap-in drywall mounting bracket.
21-930	—	White cover.
22-021	—	Universal drywall mounting kit.
22-022	N5-95	Competitor replacement mounting kit.
22-023	—	Thermostat conversion kit, white.
22-024	—	Standard mounting kit (included with thermostat).
22-693	—	Tubing kit (included with thermostat).

For additional information, refer to Accessories on page 124.

Typical Applications

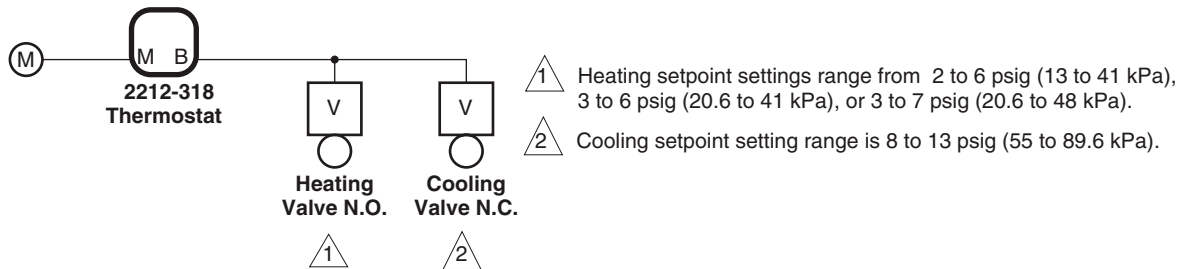

Figure 1 Typical Application.

Energy Conservation Summer-Winter Room Thermostat

This pneumatic room thermostat is designed for proportional control of pneumatic valves and damper actuators in environmental control systems where a dual pressure air main is utilized for seasonal changeover of heating and cooling functions. Its design incorporates a highly sensitive, bimetal, thermostatic element and a pilot operated relay with pneumatic feedback for accuracy and stability over the entire operating range.

Features:

- Small size: Approximately 2 x 2 in. (51 x 51 mm).
- Factory calibrated. Stainless steel ball-in-seat provides pneumatic feedback for linear, stable operation.
- Leakproof, O-Ring sealed, spring-loaded self-closing branch gauge tap.
- Separate bimetals (and setpoint scales) for heating and cooling.
- Limited setpoint ranges for energy conservation: 44 to 74°F (7 to 23°C) for winter (heating) and 76 to 85°F (24.5 to 29.5°C) for summer (cooling).
- Snap-acting (not gradual) changeover from direct action to reverse action, and vice versa.
- Concealed or visible adjustment. Image shows concealed adjustment.

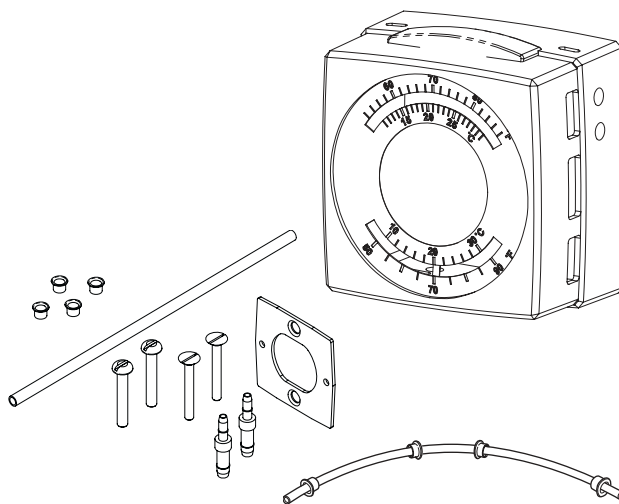

Model Chart

Model No.	Replaces Model No.	Description
2218-301	T34-3011	Refer to Specifications.

Note: Includes 1/4" by 3/16" barbed couplings, 20-693 tubing kit, 22-024 standard mounting kit, 20-928 gray plastic cover with F/C listing.

Specifications

Action	Proportional: R.A. at 15 psig (103 kPa) , D.A at 20 psig (138 kPa).
Setpoint range	44 to 74°F (7 to 23°C) winter (internal); 76 to 85°F(24 to 29°C) summer (adjustable by thumbwheel); factory installed dial stops.
Throttling range	4 F° (2.2 C°) fixed.
Construction	
Components	Die cast aluminum, stainless steel and glass-filled nylon.
Diaphragms	Fabric-reinforced neoprene.
Air filter	Internal.
Supply air pressure	Clean, dry, oil free air required (Refer to EN-123).
Summer	16 psig (110 kPa).
Winter	25 psig (172 kPa).
Connections	For spring-reinforced 3/16 in. plastic tubing and required fittings (included).
Air consumption	34.6 scim at 16 psig (9.4 mL/s at 110 kPa); 51 scim at 25 psig (14.2 mL/s at 172 kPa).
Calibration point	9 psig (62 kPa) branch line pressure.
Setpoint adjustment	Serrated thumbwheel, visible or concealed.
Mounting	Upright position on wall.
Dimensions	2-1/32 H x 2-1/32 W x 1-3/8 D in. (52 x 52 x 35 mm).

Accessories

Part Number	Replaces Model	Description
Accessories		
20-660	6-441	Cover screw (included with thermostat).
20-707	10-53	Metal thermostat guard.
20-715	10-62	Clear thermostat guard.
21-876	10-76	Opaque thermostat guard.
21-928	—	Gray plastic cover, blank dial.
21-933	—	Gray plastic cover, °F/°C dial (included with thermostat).
21-933-1	—	Gray plastic cover, Day/Night dial.
Calibration		
20-881	N2-4	Calibration wrench.
22-138	MCS-GA	Branch tap gauge adaptor.
900-002	—	Thermostat calibration kit.
Installation		
10-82-SS	—	Outlet box mounting plate, stainless steel.
20-850	10-82	Outlet box mounting plate, black.
20-642	6-371	Mounting ring.
21-473	10-73	Snap-in drywall mounting bracket.
21-930	—	White cover.
22-021	—	Universal drywall mounting kit.
22-022	N5-95	Competitor replacement mounting kit.
22-023	—	Thermostat conversion kit, white.
22-024	—	Standard mounting kit (included with thermostat).
22-693	—	Tubing kit (included with thermostat).

For additional information, refer to Accessories on page 124.

Typical Applications

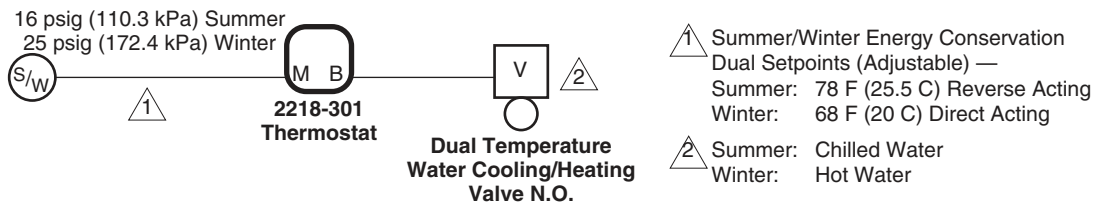

Figure 1 Typical Application.

Single Setpoint Room Thermostats

For proportional temperature control of pneumatic valves and damper actuators to maintain room air temperatures in heating, ventilating, and air conditioning systems.

Features:

- Branch-line to sensing-element pneumatic feedback for linear, stable operation.
- Plastic cover supplied with exposed setpoint and thermometer.
- Cover inserts included for:
 - Exposed setpoint only.
 - Blank face plate with logo.

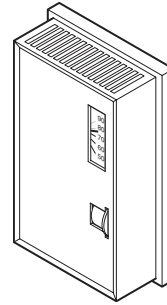

TK-1xx1

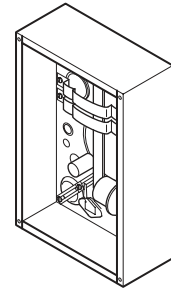

TK-1xxx-600 Aspirated Thermostat
(Shown in aspirated box without cover)

Model Chart			
Model No.	Dial Markings ^a	Control Action ^b Supply Pressure	Type Thermostat
TK-1001	55 to 85°F	Direct Acting	Two pipe
TK-1001-116	13 to 29°C		
TK-1001-600	55 to 85°F		
TK-1101	55 to 85°F	Reverse Acting	
TK-1101-116	13 to 29°C		
TK-1101-600	55 to 85°F		
TK-1201	55 to 85°F	15 psig Reverse Acting 20 psig Direct Acting	
TK-1281	55 to 85°F	20 psig Reverse Acting 15 psig Direct Acting	
TK-1301 ^c	55 to 85°F	Direct Acting 15 psig day – 20 psig night	Two pipe with manual override
TK-1301-116	13 to 29°C		
TK-1381	55 to 85°F	Reverse Acting 15 psig day – 20 psig night	
TK-1601 ^{cd}	55 to 85°F	Direct Acting 15 psig day – 20 psig night	Three pipe with manual override
TK-5001	55 to 85°F	Direct Acting	Single Pipe
TK-5001-116	13 to 29°C		
TK-5101	55 to 85°F	Reverse Acting	
TK-5101-116	13 to 29°C		

^a Dial stop pins included to limit dual range on all units.

^b Direct Acting (D.A.) increases output pressure on temperature rise. Reverse Acting (R.A.) decreases output pressure on temperature rise.

^c A manual lever is provided to change the thermostat to "Day" when the system is on "Night". The lever can be used to return to "Night" or the next cycle will return the thermostat to normal operation.

^d Has second white plastic tube to pass full line pressure (20 psi) at night and 0 psi at day. Used to actuate items such as pressure electric switches.

Thermostats

TK-1xxx Series, TK-5xxx Series

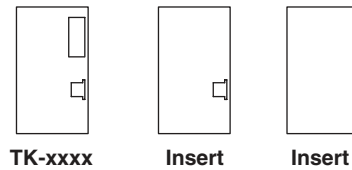

Figure 1 Cover.

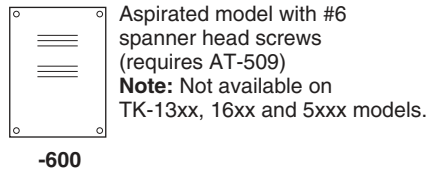

Figure 2 Aspirated Thermostat Cover.

Specifications

Thermostat	Proportional type.
Sensing element	Bimetal.
Night setback	To 20°F (11°C) below day setpoint for Day/Night heating models.
Night setup	To 20°F (11°C) above day setpoint for Day/Night cooling models.
Control dial range	Refer to Model Chart.
Throttling Range	Adjustable 2 to 10°F/10 psi, factory set at 4°F/10 psi.
Output air signal	0.5 psig to supply air pressure -0.5 psig.
Action	Refer to Model Chart.
Ambient limits	
Shipping	-40 to 150°F (-40 to 65°C). 0 to 98% RH, non-condensing.
Operating	40 to 150°F (4 to 65°C). 10 to 98% RH, non-condensing.
Supply air pressure	Clean, oil free, dry air required (refer to EN-123).
Nominal	Refer to Model Chart.
Maximum	30 psig (207 kPa).
Air connections	
Main (black)	5/32 in. dia. spring reinforced plastic tubing.
Branch (white)	5/32 in. dia. spring reinforced plastic tubing.
Air consumption for sizing air compressor	
TK-1001, 1101, 12x1, 13x1	13.8 scim (3.8 mL/s).
Air capacity for sizing air mains	
TK-1001, 1101, 12x1, 13x1,	16 scim (4.4 mL/s).
TK-16x1	32 scim (8.8 mL/s).
Cover	Beige plastic.
Mounting	Upright position on wall.
Dimensions	4-3/8 H x 2-3/4 W x 1-5/8 D in. (111 x 70 x 43 mm).

Accessories

Part Number	Description
20-944	Restrictor tee, copper tubing.
21-038	Restrictor tee, polyethylene tubing.
21-153	In-line restrictor.
AT-11-600	Aspirating conversion kit.
AT-11-1	Replacement kit fittings.
AT-11-500	Fahrenheit cover kit.
AT-11-501	Celcius cover kit.
AT-12-500	Fahrenheit cover kit for TK-13xx and TK-16xx.
AT-12-501	Celcius cover kit for TK-13xx and TK-16xx.
AT-101	Lock cover kit.
AT-104 ^a	Dial stop pins.
AT-504	Plaster hole cover (small).
AT-505	Surface mounting base.
AT-506	Pneumatic wall box fitting (two tubes for TK-100x and 110x).
AT-533-101	Adaptor 1/4 in. plastic to 5/32 in. plastic.
AT-533-127	Adaptor 3/16 in. copper or 1/4 in. copper with 1/4 in. solder coupling (not included) to 5/32 in. plastic.
AT-536	Pneumatic wall thermostat conversion kit.
AT-546	Auxiliary mounting base.
TOOL-015	Spanner head driver to #6 spanner head screws.
TOOL-095-1	Pneumatic calibration tool kit.
Maintenance Parts	
APNT-011-11	Black tubing 9 inch.
APNT-011-21	White tubing 9 inch.
APNT-093-30	Tubing spring.
AT-520-11	Relay repair kit.
AT-512-10	Replacement auxiliary nozzle kit.
AT-527	Pilot restrictor kit for aspirated (-600) models.
AT-528	Pilot restrictor kit for non-aspirated models.
PKG-1019	Mounting hardware kit.

^a All thermostats are shipped with two dial stop pins.

Typical Applications

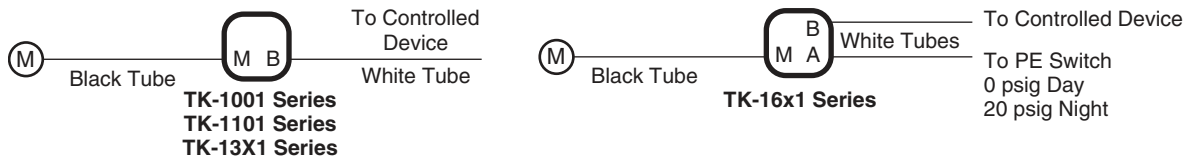

Figure 3 Two Pipe (Relay) Type.

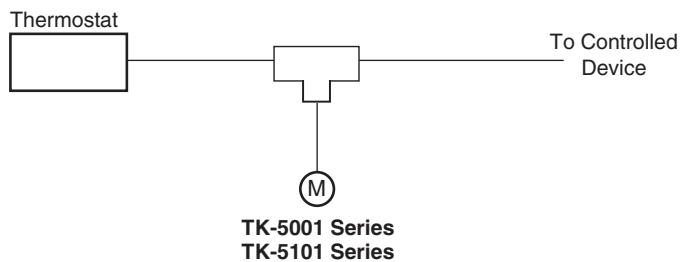

Figure 4 Single Pipe Type.

Dual Setpoint, Single Output Room Thermostats

For proportional control of pneumatic-actuated valves and damper actuators to maintain room air temperatures in heating, ventilating, and air conditioning systems.

Features:

- Branch-line to sensing-element pneumatic feedback for linear, stable operation.
- Plastic cover supplied with exposed setpoint and thermometer.
- Cover insert included with a blank face plate with logo.

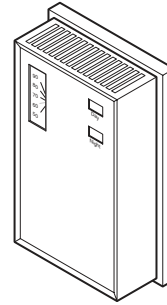

TK-17xx

Model Chart						
Model No.	15 psig Supply Pressure			20 psig Supply Pressure ^a		
	Dial Range ^b	Control Action ^c	Cover Legend ^d	Dial Range ^b	Control Action ^c	Cover Legend
TK-1717	55 to 85°F	Direct	Heat	55 to 85°F	Direct	Cool
TK-1727		Reverse			Reverse	
TK-1731		Reverse			Direct	
TK-1741		Direct	Reverse			
TK-1711		Direct	Day		Direct	Night
TK-1751 ^e		Reverse			Reverse	
TK-1721		Reverse				
TK-1761						

- ^a 22 psi required if setpoints are more than 20°F apart.
- ^b Control dial is marked in °F on one side and °C on the other side. Units have built-in stops that can limit high and/or low setting of each dial.
- ^c Direct Acting (D.A.) — Increase output pressure on temperature rise.
Reverse Acting (R.A.) — Decrease output pressure on temperature rise.
- ^d For additional options or to reverse heat/cool legend, order cover replacement kit AT-46-500 Heat/Cool, Cool/Heat or Day/Night.
- ^e Units include a manual override lever for overriding 22 psig (152 kPa) operation and placing control into 15 psig (103 kPa) control mode when unit is supplied with 22 psig (152 kPa). Lever automatically resets when supply pressure is reduced to 15 psig (103 kPa).

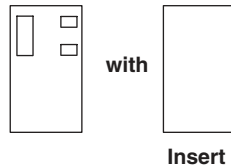

Figure 1 Covers.

Thermostats

Specifications

Thermostat	Proportional two pipe type. Two pressure Heating/Cooling or Day/Night thermostats switch between two bimetal sensors.
Sensing element	Two bimetals.
Control dial range	Two independent with stops. Refer to Model Chart.
Throttling range	Independently adjustable for each setpoint dial 2 to 10°F/10 psi change in branch line pressure, factory set at 4°F/10 psi.
Output air signal	0.5 psig (3.4 kPa) to supply air -0.5 psig (-3.4 kPa).
Action	Refer to Model Chart.
Ambient limits	
Shipping	-40 to 150°F (-40 to 65°C). 0 to 98% R.H., non-condensing.
Operating	20 to 115°F (-7 to 46°C). 10 to 98% R.H., non-condensing.
Supply air pressure	
Requires	15 and 22 psig (103 and 152 kPa) dual pressure. Refer to Model Chart.
Maximum	30 psig (207 kPa).
Air connections	
Main (black)	5/32 in. dia. spring reinforced plastic tubing.
Branch (white)	5/32 in. dia. spring reinforced plastic tubing.
Air consumption for sizing air compressor	13.8 scim (3.8 mL/s).
Air capacity for sizing air mains	80 scim (21.8 mL/s).
Cover	Beige plastic with inserts as standard except aspirated model. Aspirated model has brushed stainless steel covers.
Mounting	Upright position on wall.
Dimensions	4-3/8 H x 2-3/4 W x 1-5/8 D in. (111 x 70 x 43 mm).

Accessories

Part Number	Description
20-944	Restrictor tee, copper tubing.
21-038	Restrictor tee, polyethylene tubing
21-153	In-line restrictor.
AT-11-600	Aspirating conversion kit.
AT-11-1	Replacement kit fittings.
AT-46-500	Dual setpoint cover kit with Day/Night, Heat/Cool, Cool/Heat and blank insert with logo.
AT-47-500	Dual setpoint cover kit with Day/Night and manual override switch.
AT-504	Plaster hole cover.
AT-505	Surface mounting base.
AT-506	Pneumatic wall box fitting.
AT-509	Wall box required for aspirated thermostats.
AT-536	Pneumatic wall thermostat conversion kit.
AT-546	Auxiliary mounting base.
AT-533-101	Adapter 1/4 in. plastic to 5/32 in. plastic.
AT-533-127	Adapter 3/16 in. copper or 1/4 in. copper with 1/4 in. solder coupling (not included) to 5/32 in. plastic.
AT-533-129	5/32" x 5/32" barbed brass connector.
TOOL-015	Spanner head driver for #6 spanner head screws.
TOOL-080-1	Calibration tool.
TOOL-095-1	Pneumatic calibration tool kit.
Maintenance Parts	
APNT-011-11	Black tubing 9 inch.
APNT-011-21	White tubing 9 inch.
APNT-093-30	Tubing spring.
AT-520-11	Relay repair kit.
AT-512-10	Replacement auxiliary nozzle kit.
AT-527	Pilot restrictor kit for aspirated (-600) models.
AT-528	Pilot restrictor kit for non-aspirated models.
PKG-1019	Mounting hardware kit.

TK-17xx Series

Typical Applications



Figure 2 Typical Application.

Thermostats

Unitary Bulb Thermostats

For proportional temperature control of pneumatic valves and actuators to maintain discharge temperature of reheat systems and sampling chamber or return air temperature of terminal units and as a proportional low limit thermostat.

Features:

- Proportional, two-pipe nozzle and flapper design.
- One-pipe model available for use as low-limit controller.
- Adjustable throttling range.
- Straight, coiled or averaging liquid-filled sensing elements.
- Rugged design.
- Direct Acting or DA/RA models available.

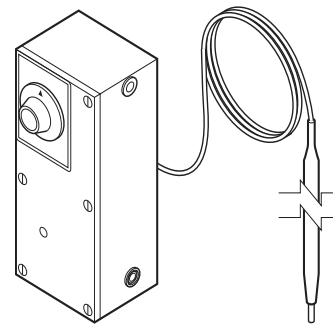

(Shown with straight bulb)

Model Chart								
Model No.	Description and Action ^a psi (kPa)	Max. Safe Bulb Temp. °F (°C)	Bulb Style Dimensions in. (mm)	Control Dial Range °F (°C)	Throttling Range	Supply Air Pressure psig (kPa)		
TK-2001	Heating D.A. ^b	140 (60)	Straight 1/4 x 11-1/2 (6.35 x 287)	Dial Marked "Cooler- Warmer" 60 to 90 (15 to 32)	Adjustable 2 to 10°F (1 to 6°C)/ 10 psi (69 kPa) Factory Set 4°F (2°C)/ 10 psi (69 kPa)	15 (103) Minimum 20 (138) Nominal		
TK-3001			Coiled 1 x 5 (25 x 127)					
TK-4001			Averaging 1/8 x 48 (3 x 1.2 m)					
TK-2201	Heating-Cooling 20 (138) D.A. 15 (103) R.A.	140 (60)	Straight 7/32 x 14 (6 x 356)			Dial Marked "Cooler- Warmer" 30 to 90 (-1 to 32)	Adjustable 5 to 25°F (3 to 14°C)/ 10 psi (69 kPa) Factory Set 10°F (6°C)/ 10 psi (69 kPa)	15 (103) R.A. ^a Cooling 20 (138) D.A. ^a Heating
TK-3201			Coiled 1 x 5 (25 x 127)					
TK-2012	Heating D.A. ^b	230 (110)	Straight 3/16 x 11-1/4 (5 x 286)	Dial Marked "Cooler- Warmer" 30 to 90 (-1 to 32)	Adjustable 5 to 25°F (3 to 14°C)/ 10 psi (69 kPa) Factory Set 10°F (6°C)/ 10 psi (69 kPa)			15 (103) Minimum 20 (138) Nominal
TK-4012			Averaging 3/32 x 54 (2 x 1.4 m)					
TK-4212	Heating-Cooling 20 (138) D.A. 15 (103) R.A.	230 (110)	Averaging 3/32 x 54 (2 x 1.4 m)					15 (103) R.A. ^a Cooling 20 (138) D.A. ^a Heating
TK-4212-201	Heating-Cooling Low Limit ^c 20 (138) D.A. Full Output 15 (103)		Averaging 3/32 x 54 (2 x 1.4 m)			15 (103) Full Output 20 (138) D.A. ^a Heating		

^a Direct Acting (D.A.) — Increase output pressure on temperature rise.
Reverse Acting (R.A.) — Decrease output pressure on temperature rise.

^b Field changeable to reverse acting.

^c At 20 psi (138 kPa) unit can bleed down a branch line from a controlling thermostat.
At 15 psi (103 kPa) unit is inoperative, i.e., passes controlling thermostat signal.

Thermostats

TK-2xxx Series, TK-3xxx Series, TK-4xxx Series, TK-4212-201

Specifications

Thermostat	Proportional type using balanced lever system.
Sensing element	Liquid-filled copper with 3 ft. (914 mm) capillary.
Control dial range	Refer to Model Chart.
Throttling range	Refer to Model Chart.
Output air signal	1 psig (6.9 kPa) to supply air pressure -1.0 psig (-6.9 kPa).
Action	Refer to Model Chart.
Ambient limits	
Shipping	-40 to 140°F (-40 to 60°C). 0 to 98% R.H., non-condensing.
Case operating	40 to 140°F (4 to 60°C). 10 to 98% R.H., non-condensing.
Bulb	Refer to Model Chart.
Supply air pressure	Clean, oil free, dry air required (refer to EN-123).
Nominal	Refer to Model Chart.
Minimum	Refer to Model Chart.
Maximum	30 psig (207 kPa).
Air connections	Post with barb for 1/4 in. O.D. plastic tubing.
Air consumption for sizing air compressor	27.6 scim (8 mL/s) at 15 psig (103 kPa), 41.5 scim (11 mL/s) at 20 psig (138 kPa).
Air capacity for sizing air mains	40 scim (11.1 mL/s) at 15 psig (103 kPa), 56 scim (15.7 mL/s) at 20 psig (138 kPa).
Mounting	Directly by means of top mounting holes or with a right angle mounting bracket included with thermostat.
Case dimensions	4-5/8 H x 2-1/8 W x 1-5/8 D in. (117 x 54 x 41 mm).

Accessories

Part Number	Description
AT-11-600	Aspirating kit.
AT-208	Duct mounting kit.
AT-529	Restrictor kit.
TOOL-095-1	Pneumatic calibration tool kit.

Typical Applications

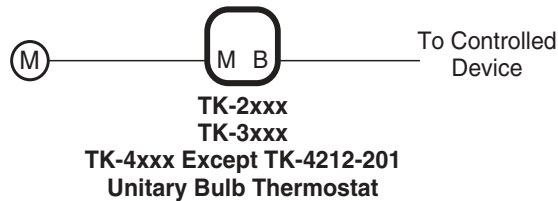
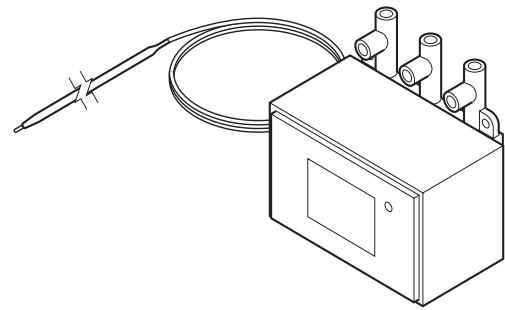

Figure 1 Typical Application.

Relay Bulb Thermostats

For proportional temperature control of pneumatic valves and actuators to maintain air or liquid temperatures in duct, plenum chambers, liquid lines, tanks, etc. May also be used as a low limit thermostat.



TK-6024 Shown

Features:

- Two-pipe (Main and Branch) controllers.
- Direct or Reverse Action.
- Liquid-filled sensing elements: Remote-bulb with 6 ft. (1.8 m) capillary, or 8 ft. (2.44 m) averaging element.
- Field-adjustable throttling range.

Model Chart			
Model No.	Action	Bulb	
		Style	Dimensions
TK-6024	D.A. ^a	Straight	3/8 x 4-5/8 in. (9.5 x 117 mm).
TK-8024		Averaging	3/32 in. x 8 ft. (2.4 mm x 2.4 m).
TK-6124	R.A. ^a	Straight	3/8 x 4-5/8 in. (9.5 x 117 mm).
TK-8124		Averaging	3/32 in. x 8 ft. (2.4 mm x 2.4 m).

^a Direct Acting (D.A.) — Increase output pressure on temperature rise.
Reverse Acting (R.A.) — Decrease output pressure on temperature rise.

Specifications	
Thermostat	Proportional two pipe type. Thermostats are ambient compensated.
Sensing element	Remote liquid-filled copper.
Control dial range	-20 to 240°F (-29 to 115°C). Shipped as -20 to 120°F, reverse side of dial 100 to 240°F.
Throttling range	Adjustable 3 to 35°F/10 psi (2 to 19°C/69 kPa) change in output, factory set at 5°F (3°C).
Output air signal	0.5 psig (3.4 kPa) to supply air pressure -0.5 psig (-3.4 kPa).
Action	Refer to Model Chart.
Ambient limits	
Shipping	-40 to 150°F (-40 to 65°C). 0 to 98% R.H., non-condensing.
Case operating	40 to 150°F (4 to 65°C). 10 to 98% R.H., non-condensing.
Bulb	310°F (154°C) maximum.
Supply air pressure	
Nominal	20 psig (138 kPa).
Minimum	15 psig (103 kPa).
Maximum	30 psig (207 kPa).
Air connections	1/8 in. FNPT for main, branches, and AL-362 gages (not included).
Air consumption for sizing air compressor	13.8 scim (3.8 mL/s).
Air capacity for sizing air mains	16 scim (4.4 mL/s).
Mounting	Upright position on a wall or vertical flat surface.
Bulb dimensions	Refer to Model Chart.
Capillary length	6 ft. (1.8 m).
Case dimensions	5-13/16 H x 6-3/16 W x 4 D in. (148 x 157 x 102 mm).

TK-6xxx Series, TK-8xxx Series

Accessories

Part Number	Description
AL-362	Stem mounted back connected 0 to 30 psi gauge.
AT-201	3/8 x 9-1/2 in. with 3/4 in. MNPT copper bulb well requires AT-209.
AT-203	3/8 x 9-1/2 in. with 3/4 in. MNPT stainless steel bulb well requires AT-209.
AT-206	3/8 x 4-1/2 in. with 1/2 in. MNPT copper bulb well.
AT-208	Duct mounting kit.
AT-209	Liquid line or tank mounting kit.
AT-211	Bulb shield.
AT-539	Pilot pressure kit.
TOOL-095-1	Pneumatic calibration tool kit (required for use as low limit thermostat).
Maintenance Parts	
AT-520-11	Relay repair kit
AT-528	Pilot restrictor kit.

Typical Applications

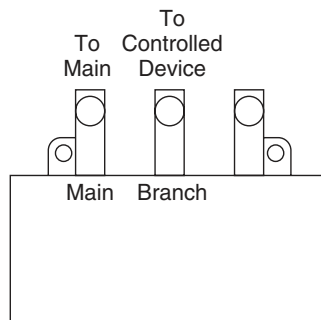

Figure 1 Typical Application.

Transmitters

Table of Contents

Humidity

- 2232-150 104
- HKS-2033, HKS-5033 106

Pressure

- 2301 Series 108
- 2302 Series 109
- 2323-5xxx Series 111

Temperature

- 2220-053 113
- 2252 Series 115
- TKS-5001, TKS-6001 117

All specifications are nominal and may change as design improvements are introduced. Schneider Electric shall not be liable for damages resulting from misapplication or misuse of its products.

Duct Relative Humidity Transmitter

The Relative Humidity Transmitter is designed to measure relative humidity in an air duct and transmit a 3 to 15 psig pneumatic signal over its 0 to 100% R.H. span to remote controlling, indicating, and alarm devices such as receiver-controllers, receiver gauges, and sensitive pressure switches.

Features:

- Widest possible (0 to 100%) relative humidity range for 3 to 15 psig (21 to 103 kPa) output.
- Shielded, highly sensitive, temperature-compensated nylon sensing element, designed for duct insertion.
- Force-balanced pneumatic feedback for stable, repeatable operation.

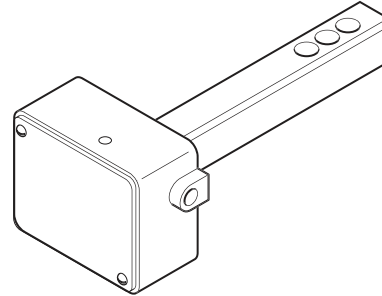

Model Chart

Model No.	Replaces Model	Description
2232-150	H150-100	Refer to Specifications.

Specifications

Control action	Direct acting, proportional.
Max. ambient temperature limit	140°F (60°C).
Humidity range	0 to 100% R.H.
Air pressure	
Operating	20 psig (138 kPa).
Maximum	30 psig (207 kPa).
Construction	
Element	Hygroscopic nylon tape sensing element.
Housing	Die cast aluminum.
Dimensions	
Case	2-5/8 H x 2-1/16 W x 1-3/4 D in. (67 x 78 x 44 mm).
Element	1-5/16 H x 7/8 W x 5-5/8 D in. (33 x 22 x 143 mm).
Weight	0.9 lb (0.4 kg).
Air consumption	29 scim (7.9 mL/s).

Accessories

Part Number	Replaces Model	Description
20-944	N4-32	Restrictor tee, copper tubing.
21-038	N100-0010	Restrictor tee, polyethylene tubing.
21-153	N100-2501	In-line restrictor.

Typical Applications

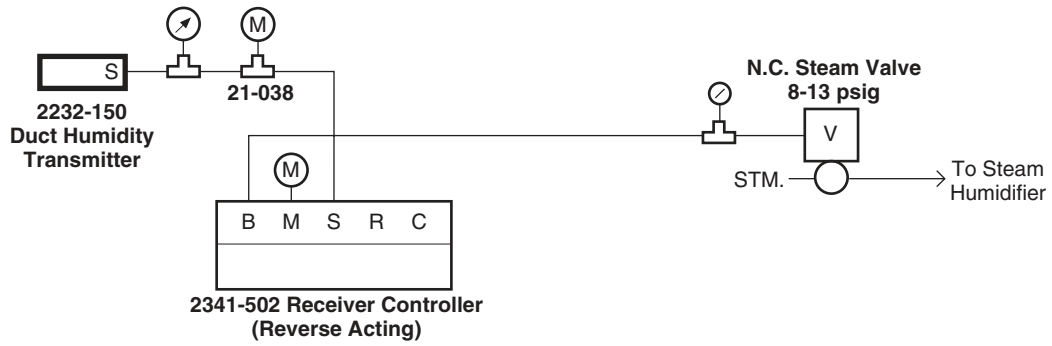

- 1 2232-150 is usually located in the return (or exhaust) air duct, to measure space relative humidity.
- 2 When the air-handling unit fan motor is de-energized, the E/P relay removes control air from the normally closed steam valve, closing it fully.

Figure 1 Typical Applications.

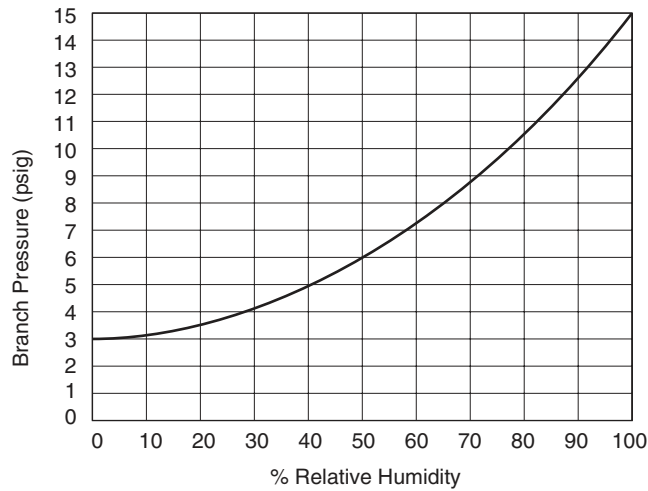

Figure 2 Relative Humidity vs. Branch Pressure.

Transmitters

Room/Duct Humidity Transmitters

For proportional humidity control used with receiver-controllers. May be used with calibrated gauges for continuous humidity indication at any local or remote position.

Features:

- 10 to 90% relative humidity range for 3 to 15 psig (21 to 103 kPa) output.
- Highly sensitive nylon sensing element.
- Pneumatic feedback for stable, repeatable operation.

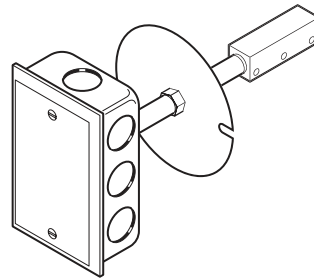

HKS-2033

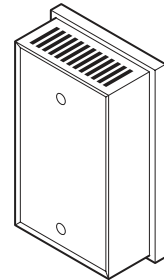

HKS-5033

Model Chart	
Model No.	Description
HKS-2033	Duct humidity transmitter.
HKS-5033	Room humidity transmitter.

Specifications	
Sensing element	Nylon.
Sensing	
Span	80% RH.
Range	10 to 90% RH (non-adjustable).
Output air signal	3 to 15 psig (21 to 103 kPa).
Action	Direct.
Ambient limits	
Shipping	-40 to 150°F (-40 to 65°C). 0 to 98% RH, non-condensing.
Operating	-20 to 125°F (-29 to 52°C). 10 to 98% RH, non-condensing. 10 to 2500 fpm (0.05 to 12.7 m/s) sensed air velocity.
Supply air pressure	Clean, oil free, dry air required (refer to EN-123).
Nominal	20 psig (138 kPa) through 0.0075 in. (190 μm) restrictor.
Minimum	18 psig (124 kPa).
Maximum	30 psig (207 kPa).
Air connections	
HKS-2033	Barbed for 1/4 in. O.D. plastic tubing.
HKS-5033	5/32 in. diameter spring reinforced plastic tubing.
Air consumption for sizing air compressor	41.5 scim (11.3 mL/s).
Air capacity for sizing air mains	48 scim (13.2 mL/s).

Transmitters

Specifications (Continued)

Mounting	
HKS-2033	Duct.
HKS-5033	Wall (has beige plastic cover).
Dimensions	
HKS-2033	4-3/16 H x 4 W x 2-1/16 D in. (106 x 102 x 52 mm); tube mounting hole diameter is 1-3/8 in. (35 mm) and tube insertion length is 4-1/4 in. (108 mm).
HKS-5033	4-3/8 H x 2-3/4 W x 1-5/8 D in. (111 x 70 x 43 mm). Order fittings separately for type of wall construction.

Accessories

Part Number	Description
20-944	Restrictor tee, copper tubing.
21-038	Restrictor tee, polyethylene tubing.
21-153	In-line restrictor.
AT-504	Plaster hole cover (small).
AT-505	Surface mounting base.
AT-506	Pneumatic wall box fitting (two tubes) used for mounting under cover of HKS-5033.
AT-533-101	Adaptor 1/4 in. plastic to 5/32 in. plastic.
AT-533-127	Adaptor 3/16 in. copper or 1/4 in. copper with 1/4 in. solder coupling (not included) to 5/32 in. plastic.
AT-533-129	5/32" x 5/32" Barbed brass connector.

Typical Applications

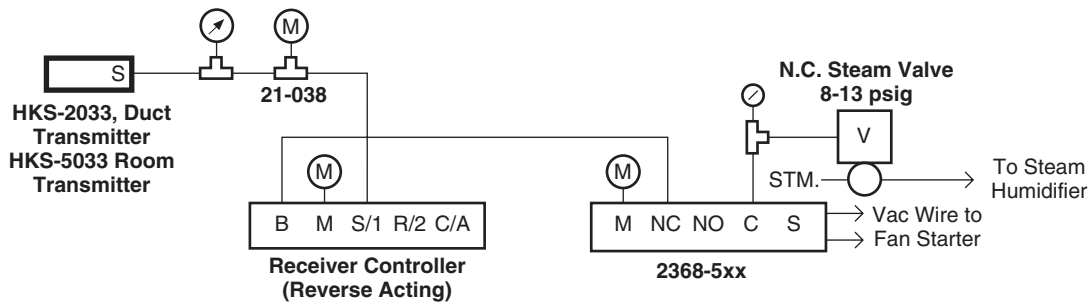

- 1 HKS-2033 is usually located in the return (or exhaust) air duct, to measure space relative humidity.
- 2 HKS-5033 is wall mounted, in the room, to measure area relative humidity.
- 3 When the air-handling unit fan motor is de-energized, the E/P relay removes control air from the normally closed steam valve, closing it fully.

Figure 1 Typical Application.

Pressure Transmitters

The pneumatic pressure transmitters are designed to measure either air or fluid pressures. All models transmit a fixed-span, 3 to 15 psig output signal proportional to input pressure to controlling and indicating devices such as receiver-controllers, receiver gauges, and certain pneumatic relays and alarm devices. These transmitters are available in various pressure ranges to meet most control system application requirements.

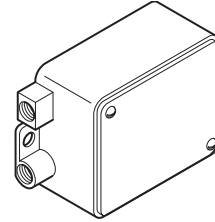

Features:

- Single-input pressure transmitter permits remote readout on receiver gauge, and control of air, water, steam or refrigerant pressure from a convenient location.
- Three different ranges permit proper match of transmitter range to application.
- Quality design and construction ensure linearity and responsiveness.
- Factory calibrated.
- Field adjustable “zero”.

Model Chart

Model No.	Replaces Model No.	Input Pressure Range (psig)	Maximum Safe Pressure (psig)
2301-040	P301-040	-10 to +40 (-69 to 276 kPa)	65 (448 kPa)
2301-150	P301-150	0 to 150 (0 to 1034 kPa)	185 (1276 kPa)
2301-300	P301-300	0 to 300 (0 to 2068 kPa)	350 (2413 kPa)

Specifications

Output	3 to 15 psig (21 to 103 kPa).
Control Action	Direct, proportional.
Maximum ambient temperature	140°F (60°C).
Supply air pressure	Clean, dry, oil free air required (refer to EN-123).
Nominal	20 psig ±0.5 psig (138 kPa ±3.4).
Maximum	30 psig (207 kPa).
Connections	Two 1/8 in. FNPT.
Air consumption	27.7 scim (7.5 mL/s).
Air capacity	48 scim.
Adjustments	Minor “zero” adjustment only.
Calibration	None; factory calibrated.
Mounting	External mounting ears are provided for easy mounting to panels or ducts.
Dimensions	2-5/8 H x 3-1/16 W x 1-3/4 D in. (66 x 78 x 45 mm).
Weight	15 oz.

Accessories

Part Number	Replaces Model	Description
20-944	N4-32	Tee restrictor for copper or plastic tubing.
21-038	N100-0010	Tee restrictor for plastic tubing.
21-153	N100-2501	In-line restrictor.
2422-001	—	2-1/2" Receiver gauge.
2422-002	—	3-1/2" Receiver gauge.
2422-003	—	2" Receiver gauge.
2890-001	—	Overlay kit.
2890-002	—	Overlay kit.
2890-003	—	Overlay kit.

Typical Applications

Figure 1 Typical Piping Diagram.

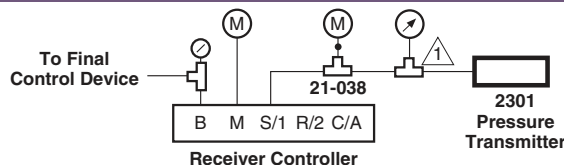

Receiver Gauge scale to match Transmitter

Differential Pressure Transmitter

The 2302 series differential pressure transmitters send a fixed span 3 to 15 psig (21 to 103 kPa) pneumatic signal which is proportional to a differential pressure being sensed. The output signal can be used as an input for receiver-controllers or gauges to indicate differential pressure.

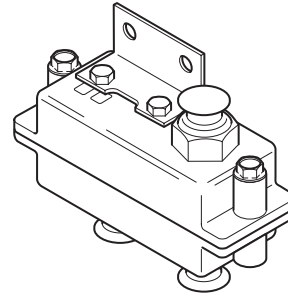

Features:

- Permits remote readout of differential pressure on receiver-gauge, and control from a convenient location.
- Provides differential pressure readout on a single receiver gauge (eliminates need to read two pressure gauges and subtract one reading from the other).
- Field-adjustable “zero”.

Model Chart			
Model No.	Replaces Model No.	Differential Pressure Sensed psi (kPa)	Max. Differential Pressure psig (kPa)
2302-051	PKSR-9001	0 to 50 (0 to 345)	85 (586)

Specifications	
Transmitter	Non-relay.
Construction	Zinc diecast case, brass fittings.
Sensed medium	Water, air, steam, oil.
Maximum total pressure (any input)	300 psig (2069 kPa).
Zero adjustment	Output to 3 ±1/4 psig (21 ±2 kPa) with input pressures equalized.
Output air signal	3 to 15 psig (21 to 103 kPa), span fixed.
Action	Direct.
Environment	
Ambient temperature limits	Shipping and storage: -40 to 140°F (-40 to 60°C). Operating: 40 to 120°F (4 to 49°C).
Humidity	5 to 95% RH, non-condensing.
Supply air pressure	Clean, oil free, dry air required (refer to EN-123).
Nominal	20 psig (138 kPa).
Maximum	30 psig (207 kPa).
Connections	1/8 in. FNPT.
Air consumption for sizing air compressor	27.6 scim (7.5 mL/s) at 20 psig (138 kPa).
Air capacity for sizing air mains	48 scim (13.1 mL/s) at 20 psig (138 kPa).
Mounting	In any position with integral bracket provided.
Dimensions	2-11/16 H x 3-3/4 W x 1-19/32 D in. (68 x 95 x 40 mm).

2302 Series

Accessories

Part Number	Replaces Model	Description
2422-001	A251-1	Receiver gauge 2-1/2 in.
2422-002	A252	Receiver gauge 3-1/2 in.
2422-003	A253-12	Receiver gauge 2 in.
21-038	N100-0010	Restrictor tee for use with 1/4 in. O.D. plastic tubing.
21-153	N100-2501	In-line restrictor.
20-944	N4-32	Restrictor tee, copper tubing.

Receiver Gauge Overlays

Model No.		Description
2890-001	—	2 in. overlay kit.
2890-002	—	2-1/2 in. overlay kit.
2890-003	—	3 in. overlay kit.

Typical Applications

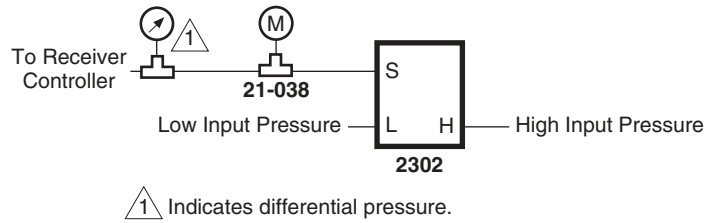
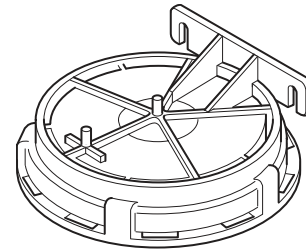

Figure 1 Piping Connections.

Differential or Static Pressure Transmitters

The 2323-5xx Series differential or static pressure transmitters have been designed to sense differential or static pressure across fans, coils, filters, or between two reference points and to transmit a 3 to 15 psig signal to controlling and indicating devices such as receiver controllers, receiver gages, and sensitive pressure switches.

These devices are one-pipe transmitters which require an external restrictor in the supply line. Their design features pneumatic feedback, which ensures accuracy and stability over the entire operating range. Mounting ears are provided for strain-free mounting on ducts or other flat surfaces.



Features:

- Permits remote readout and control of differential or static pressure of air.
- Five different ranges permit proper match of transmitter range to various applications.
- Ball-in-seat pneumatic feedback ensures linearity and responsiveness.
- Field-adjustable “zero”.

Model Chart		
Model No.	Replaces Model No.	Range W.C. (Pa)
2323-505	P323-0025	-0.05 to +0.20 in. (-12.45 to 49.8)
2323-503	P323-01	-0.5 to +0.5 in. (-124.5 to 124.5)
P323-101	—	0 to 1 in. (0 to 249)
2323-500	P323-03	0 to 3 in. (0 to 747)
2323-504	P323-10	0 to 10 in. (0 to 2490)

Specifications	
Control action	Direct, proportional.
Pressure output	3 to 15 psig (20.7 to 103.5 kPa) for stated span.
Environment	
Maximum ambient temperature	140°F (60°C).
Locations	Avoid areas with excessive vibration or corrosive materials.
Supply air pressure	
Nominal	20 psig (138 kPa).
Maximum	30 psig (207 kPa).
Connections	Nipples for 1/4 in. O.D. polyethylene tubing except LO and HI ports which require 3/8 in. O.D. polyethylene tubing.
Main air consumption	27.7 scim (7.5 mL/s).

2323-5xx Series

Specifications (Continued)

Air capacity	48 scim.
Calibration	Factory set.
Mounting	Transmitter must be mounted in a horizontal position with the correct side up.
Dimensions	5-9/16 H x 5-5/16 W x 2-11/16 D in. (141 x 135 x 69 mm).
Weight	0.5 lb (227 g).

Accessories

Part Number	Replaces Model	Description
2422-001	A251-1	2-1/2 in. gauge.
2422-002	A252	3-1/2 in. gauge.
2422-003	A253-12	2 in. gauge.
AP-302	—	Static pressure sensing tip — 1/4 in. O.D. tubing.
AP-305	—	Static pressure sensing tip, 1/8 in. pipe thread.
20-944	N4-32	Restrictor tee for copper tubing.
21-038	N100-0010	Restrictor tee for polyethylene tubing.
21-153	N100-2501	In-line restrictor.

Receiver Gauge Overlays

Model No.	Description
2890-001	2 in. overlay kit.
2890-002	2-1/2 in. overlay kit.
2890-003	3-1/2 in. overlay kit.

Typical Applications

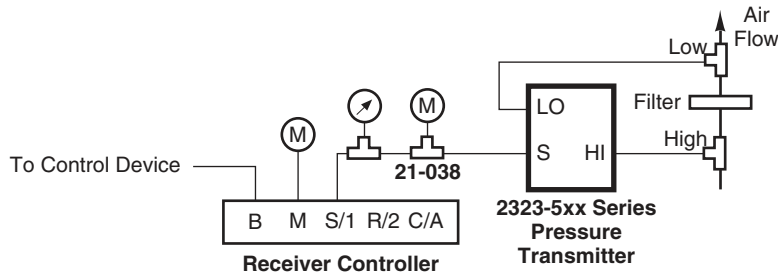

Figure 1 Differential Pressure Transmitter Application.

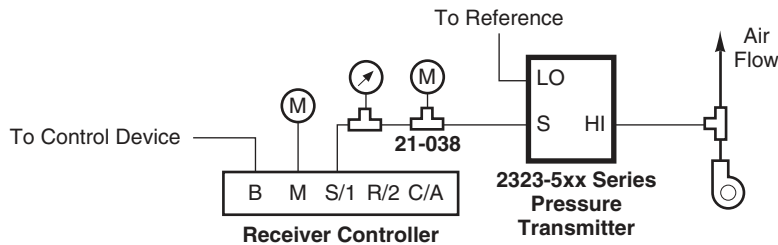
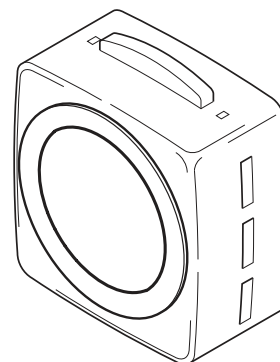

Figure 2 Static Pressure Transmitter Application.

Room Temperature Transmitter

The temperature transmitter measures room temperature and transmits a proportional pneumatic signal to a calibrated receiver gauge and/or receiver controller. The device is factory set to transmit a 3 to 15 psig (20.7 to 103.4 kPa) signal over a 50 to 90°F range.



Features:

- Permits remote readout and control of room temperature.
- Highly sensitive bimetal sensing element.
- Linear response to room temperature changes.
- Matches appearance of 2 x 2 in. Thermostats, 2230-018 Humidistat, and 2232-053 R.H. Transmitter.
- Field-adjustable “zero” adjustment.

Model Chart

Model No.	Replaces Model No.	Description
2220-053	T53-101	Refer to Specifications.

Note: Includes 1/4" by 3/16" barbed couplings, 20-693 tubing kit, 22-024 standard mounting kit, 20-928 gray plastic cover with F/C listing.

Specifications

Action	Direct acting, proportional.
Temperature Range	50 to 90°F (10 to 32°C), fixed.
Construction	
Components	Die cast aluminum, stainless steel, and glass-filled nylon.
Diaphragms	Fabric-reinforced neoprene.
Air filter	Internal.
Supply air pressure	Clean, dry, oil free air required (Ref. EN-123).
Nominal	20 ±0.5 psig (138 kPa).
Maximum	30 psig (207 kPa).
Connections	For spring-reinforced 3/16 in. plastic tubing and required fittings (included).
Calibration point	Refer to Figure 1.
Mounting	Upright position on wall.
Dimensions	2-1/32 H x 2-1/32 W x 1-3/8 D in. (52 x 52 x 35 mm).

Accessories

Part Number	Replaces Model	Description
Accessories		
20-660	6-441	Cover screw (included with thermostat).
20-707	10-53	Metal thermostat guard.
20-715	10-62	Clear thermostat guard.
21-876	10-76	Opaque thermostat guard.
21-928	—	Gray plastic cover, blank dial.
21-933	—	Gray plastic cover, °F/°C dial (included with thermostat).
21-933-1	—	Gray plastic cover, Day/Night dial.
Calibration		
20-881	N2-4	Calibration wrench.
22-138	MCS-GA	Branch tap gauge adaptor.
900-002	—	Thermostat calibration kit.
Installation		
10-82-SS	—	Outlet box mounting plate, stainless steel.
20-850	10-82	Outlet box mounting plate, black.
20-642	6-371	Mounting ring.
21-473	10-73	Snap-in drywall mounting bracket.
22-021	—	Universal drywall mounting kit.
22-022	N5-95	Competitor replacement mounting kit.
22-024	—	Standard mounting kit (included with thermostat).
22-693	—	Tubing kit (included with thermostat).

Typical Applications

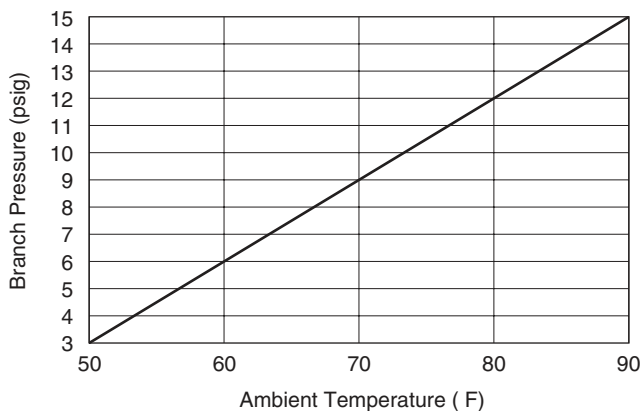

Figure 1 Branch Pressure vs. Ambient Temperature.

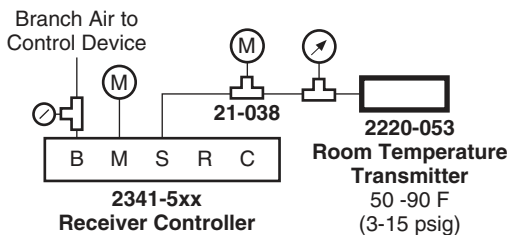

Figure 2 Typical Application.

Duct, Immersion and Outdoor-Air Temperature Transmitters

The 2252 Series pneumatic temperature transmitters are designed to measure air or fluid temperatures in pneumatic control systems and transmit a fixed span, 3 to 15 psig (20 to 103 kPa) signal to controlling and indicating devices such as receiver controllers, receiver gauges, sensitive pressure switches, or snap-acting 2353-501 diverting relays. These transmitters are available with several types of sensing elements.

These transmitters are “one-pipe” devices requiring an externally restricted source of constant pressure control air. Their design features pneumatic feedback to ensure accuracy and stability over their temperature span.

Features:

- Permits remote readout and/or control of temperatures associated with HVAC systems.
- Eight different ranges permit proper match of transmitter range to applications.
- Quality design and construction, with beryllium copper feedback bellows, provides excellent linearity, response and stability.
- Field-accessible “zero” adjustment.
- Liquid-filled sensing elements in the following styles:
 - 20 ft. (6.1 m) averaging, for air ducts.
 - Rigid, for immersion (in well), or air duct insertion.
 - 10 in. (25.4 cm) rigid coiled, for fast response in air ducts where averaging is not required.
 - Remote-bulb, for various applications.

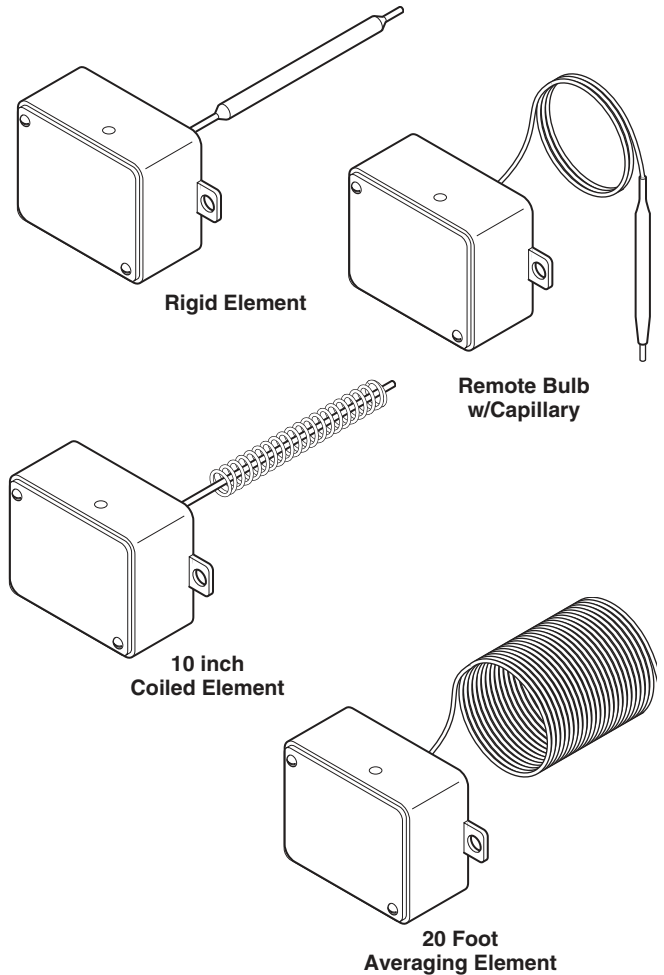

Model Chart					
Model No.	Replaces Model No.	Range (non-adjustable) °F (°C)	Span °F (°C)	Mounting	Sensing Element Description
2252-510	T150-1011	40 to 140 (4 to 60)	100 (56)	Duct or immersion	Rigid element, 1/4 x 9-3/8 in. long (6 x 238 mm)
2252-501	T150-1012			Duct	Averaging element, 20 ft. long (6 m)
2252-502	T150-1013			Duct	Rigid (coiled) element, 10 in. long (25.4 cm)
2252-250	T150-1021	0 to 100 (-18 to 38)	100 (56)	Duct or immersion	Rigid element, 1/4 x 9-3/8 in. long (6 x 238 mm)
2252-251	T150-1022			Duct	Averaging element, 20 ft. long (6 m)
2252-252	T150-1023			Duct	Rigid (coiled) element, 10 in. long (25.4 cm)
2252-610	T150-1031	40 to 240 (4 to 115)	200 (111)	Duct or immersion	Rigid element, 1/4 x 7-1/16 in. long (6 x 179 mm)
2252-635	T150-1035			Duct	10-1/2 x 1/4 in. (267 x 6 mm) bulb with 9 ft. (2.7 m) capillary
2252-110	T150-1041	-40 to 160 (-40 to 71)	200 (111)	Duct or immersion	Rigid element, 1/4 x 7-1/16 in. long (6 x 179 mm)

Transmitters

2252 Series

Model Chart (Continued)

Model No.	Replaces Model No.	Range (non-adjustable) °F (°C)	Span °F (°C)	Mounting	Sensing Element Description
2252-703	T150-1046	-40 to 160 (-40 to 71)	200 (111)	Duct or outdoor air	1/4 x 2.5 in. (6 x 64 mm) bulb with 42 in. (1.1 m) capillary
2252-151	T150-1054	-25 to 125 (-32 to 52)	150 (84)	Duct or outdoor air	4 x 1/4 in. (102 x 6 mm) bulb with 3 ft. (0.9 m) capillary
2252-655	T150-1055				10-1/2 x 1/4 in. (267 x 6 mm) bulb with 9 ft. (2.7 m) capillary
2252-662	T150-1062	30 to 80 (-1 to 27)	50 (28)	Duct	Averaging element, 20 ft. long (6 m)
2252-273	T150-1073	50 to 100 (10 to 38)			Rigid (coiled) element, 10 in. long (25.4 cm)
2252-701	T150-1082	50 to 150 (10 to 66)	100 (56)	Duct	Averaging element, 20 ft. long (6.1 m).
2252-702	T150-1083				Rigid (coiled) element, 10 in. long (25.4 cm)

Specifications

Action	Direct, proportional.
Adjustments	None required, factory calibrated.
Supply air pressure	Clean, dry, oil free air required (Refer to EN-123).
Nominal	20 psig ±0.5 psi (138 kPa ±3.4 kPa) through 1.0 scfh restrictor.
Maximum	30 psig (207 kPa).
Output pressure	3 to 15 psig (21 to 103 kPa).
Air connection	1/8 in. FNPT.
Maximum case ambient temperature	140°F (60°C).
Construction	Copper element, cast aluminum base, zinc plated steel cover.
Mounting	Duct or immersion (refer to Model Chart).
Weight	0.9 lb (0.4 kg).
Case dimensions	2-5/8 H x 3-1/16 W x 1-3/4 D in. (67 x 78 x 44 mm).

Accessories

Part Number	Replaces Model	Description
20-778 ^a	100-17	3/8 x 7-1/32 in. copper well with 1/2 in. NPT bushing.
20-782	100-25	3/8 x 10-17/32 in. copper well with 1/2 in. NPT bushing.
20-803 ^a	100-47	Neck extension adaptor - converts 7-1/32 in. well to 10-17/32 in. well.
20-805	100-49	3/8 x 7-1/32 in. Stainless steel well with 1/2 in. NPT bushing (includes 20-803).
22-401	100-71	Adapter, brass, for mounting 2252 Series immersion transmitter in AT-201 or AT-203 well.
20-944	N4-32	Restrictor tee, copper tubing.
21-038	N100-0010	Restrictor tee, polyethylene tubing.
21-153	N100-2501	In-line restrictor.
AT-208	—	Duct mounting kit
AT-211	—	Outdoor bulb shield

^a Use together for copper well with extended neck.

Typical Applications

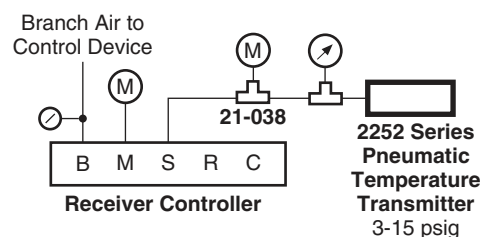

Figure 1 Typical Application.

Room and Light Troffer Temperature Transmitters

For proportional temperature control used with receiver-controllers. May be used with one or more calibrated gauges for continuous temperature indication at any local or remote position.

Features:

- Forced balanced pneumatic feedback provides stable operation.
- Highly sensitive bimetal sensing element.

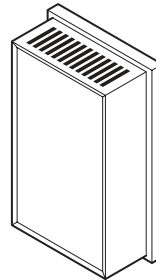

TKS-5001

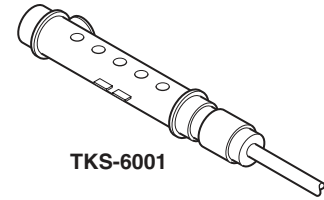

TKS-6001

Model Chart

Model No.	Mounting	Range (Non-Adj.) °F (°C)	Span °F (°C)	Sensing Element Description	Cover	Ambient Temperature Limits °F (°C)	Air Connections	Dimensions H x W x D in. (mm)
TKS-5001	Wall ^a	50 to 100 (10 to 38)	50 (28)	Bimetal	Beige Plastic	Shipping: -40 to 150 (-40 to 65) Operating: 50 to 100 (10 to 38)	5/32 in. dia. spring reinforced plastic tube	4-3/8 x 2-3/4 x 1-5/8 (111 x 70 x 41)
TKS-6001	Light Troffer				N.A.	5/32 in. dia. spring reinforced plastic tube	3/8 x 3/8 x 3 (10 x 10 x 76)	

^a Order fittings separately for type of wall construction.

Specifications

Ambient temperature	Refer to Model Chart.
Output air signal	3 to 15 psig (21 to 103 kPa).
Action	Direct.
Supply air pressure	Clean, oil free, dry air required (refer to EN-123).
Nominal	20 psig (138 kPa) through 0.0075 in. (190 µm) restrictor.
Minimum	18 psig (124 kPa).
Maximum	30 psig (207 kPa).
Air consumption for sizing air compressor	41.5 scim (11.3 mL/s).
Air capacity for sizing air mains	36 scim (13.2 mL/s).

Accessories

Part Number	Description
20-944	Restrictor tee, copper tubing.
21-038	Restrictor tee, polyethylene tubing.
21-153	In-line restrictor.
AT-201	Copper bulb well.
AT-203	Stainless steel bulb well.
AT-208	Duct mounting kit for TKS-40xx.
AT-211	Bulb shield for wall mounting TKS-2031.
AT-504	Plaster hole cover (small).
AT-506	Pneumatic wall box fitting (two tubes) used for mtg. AT-532-11-1-01 under cover of TKS-5001.
AT-533-101	Adaptor 1/4 in. plastic to 5/32 in. plastic.
AT-533-127	Adaptor 3/16 in. copper or 1/4 in. copper with 1/4 in. solder coupling (not included) to 5/32 in. plastic.
AT-533-129	5/32 in. x 5/32 in. barbed brass connector.

Typical Applications

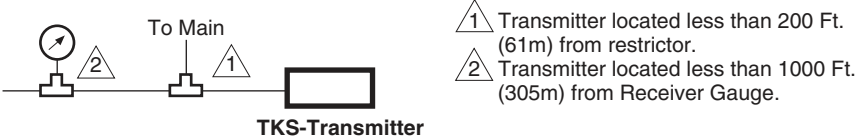

Figure 1 Typical Application.

Unitary Controllers

Table of Contents

2260 Series	120
2298 Series	121

All specifications are nominal and may change as design improvements are introduced. Schneider Electric shall not be liable for damages resulting from misapplication or misuse of its products.

Airstream Temperature Controllers

The 2260 series are one-pipe, non-relay controllers designed primarily for use as low limit thermostats in unit ventilator and central fan system applications.

Features:

- Rigid or averaging liquid-filled sensing elements.
- Field-adjustable throttling range.
- Simple, straightforward one-pipe (nozzle and flapper) operation (direct-acting).
- May be used as primary or low-limit controller.
- Includes gauge-tee and compression restrictor-tee.

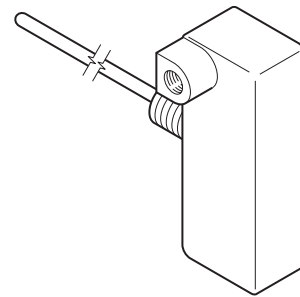

2260-550 Shown

Model Chart		
Model No.	Replaces Model No.	Sensing Element Style Dimensions
2260-550	T201-023	Rigid stem 3/16 x 19-3/8 in. (5 x 492 mm)
2260-551	T201-024	Averaging 3/32 in. x 8 ft. (2 mm x 2.4 m)

Specifications	
Thermostat	Proportional.
Sensing element	Liquid-filled.
Control dial range	40 to 150°F (4 to 65°C), marked Warmer-Cooler with 5F ° (3C°) increments.
Throttling range	10 to 50°F (6 to 28°C), field adjustable, marked A through E.
Output air signal	3 to 15 psig (21 to 103 kPa).
Control mechanism	Mounted in steel enclosure with cover.
Restriction	External-fixed; furnished for unit ventilator applications.
Construction	White molded plastic snap-on cover, iridited aluminum base.
Action	Direct only.
Maximum bulb temperature limit	250°F (121°C).
Supply air pressure	Clean, dry, oil free air required (Refer to EN-123).
Nominal	15 to 17 psig (103 to 117 kPa).
Maximum	30 psig (207 kPa).
Air connections	1/8 in. FNPT.
Air consumption for sizing air compressor	30 scim (8.2 mL/s).
Mounting	Insertion with two locknuts and washers on 3/8 in. NPSM threaded boss.
Case dimensions	3-31/64 H x 1-1/8 W x 1-7/16 D in. (89 x 29 x 36 mm).
Weight	Approx. 0.6 lbs. (0.3 kg).

Typical Applications

Figure 1 Typical Application (Heating-Only Unit Ventilator).

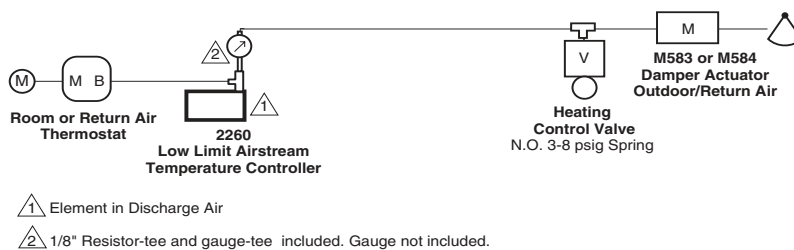

Unitary Controllers

Unit Temperature Controllers

The Unit Temperature Controllers are designed for the proportional control of pneumatic devices and actuators in environmental control systems. These devices are designed primarily as return air controllers in induction units, fan coil units, and unit ventilators.

Features:

- Small size.
- Stable, linear response to room temperature changes.
- Sensor may be mounted up to 200 ft. (61 m) from controller; connects to controller body with 1/4 in. O.D. plastic tubing.
- Summer-winter models have snap-acting changeover from direct action to reverse action and vice versa.

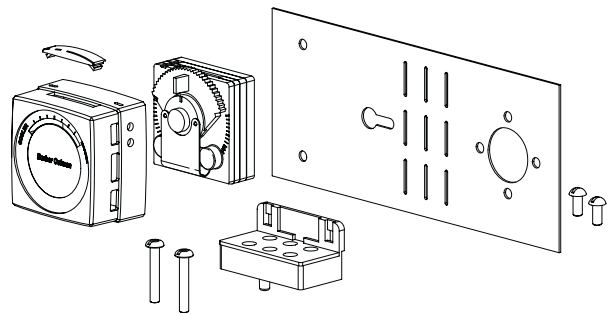

Model Chart			
Model No.	Replaces Model No.	Action	Comments
2298-060	T460-301	Reverse acting at 16 psig (110 kPa), direct acting at 25 psig (172 kPa)	Includes 20-818 mounting bracket with screws and remote bimetal sensors.
2298-061	T461-301	Direct	
2298-062	T462-301	Reverse	
2298-063	T463-301	Direct acting at 16 psig (110 kPa), reverse acting at 25 psig (172 kPa)	

Specifications	
Setpoint range	65 to 85°F.
Throttling range	4F° fixed.
Sensitivity	2.5 psig/F° fixed.
Maximum ambient temperature	140°F (60°C).
Main air pressure	Clean, dry, oil free air required (Refer to EN-123).
Nominal	2298-060: 16 psig (110 kPa) reverse acting, 25 psig (172 kPa) direct acting. 2298-061, 2298-062: 20 psig (138 kPa). 2298-063: 16 psig (110 kPa) direct acting, 25 psig (172 kPa) reverse acting.
Maximum	30 psig (207 kPa)
Connections	Fittings for 1/4 in. O.D. plastic tubing.
Air consumption	
2298-060, 2298-063	29.4 scim (8.0 mL/s) at 16 psig, 45 scim (12.3 mL/s) at 25 psig.
2298-061, 2298-062	29.4 scim (8.0 mL/s) at 16 psig.
Adjustments	External or concealed.
Calibration point	Factory calibrated at 9 psig (62 kPa) for -061 and -062; 12 psig (82.7 kPa) for -060 and -063.
Mounting	Wall mount or mounting bracket.
Dimensions	2-1/32 H x 2-1/32 W x 1-3/8 D in. (52 x 52 x 35 mm). Does not include mounting plate or remote sensor.

Accessories

Part Number	Replaces Model	Description
Accessories		
20-660	6-441	Cover screw.
20-707	10-53	Metal thermostat guard.
20-715	10-62	Clear thermostat guard.
21-876	10-76	Opaque thermostat guard.
21-928	—	Gray plastic cover, blank dial.
20-821	100-50	Remote sensor, reverse acting for 2298-060 and 2298-062.
20-822	100-51	Remote sensor, direct acting for 22-98-061 and 22-98-063.
Calibration		
20-881	N2-4	Calibration wrench.
22-138	MCS-GA	Branch tap gauge adaptor.
900-002	—	Thermostat calibration kit warmer/cooler.
Installation		
10-82-SS	—	Outlet box mounting plate, stainless steel.
20-850	10-82	Outlet box mounting plate, back.
20-642	—	Mounting ring.
20-818	—	Mounting bracket.
21-473	10-73	Snap-in drywall mounting bracket.
22-021	—	Universal drywall mounting kit.
22-022	N5-95	Competitor replacement mounting kit.
22-024	—	Standard mounting kit.
Maintenance Parts		
21-929-1	—	Replacement cover.

Typical Applications

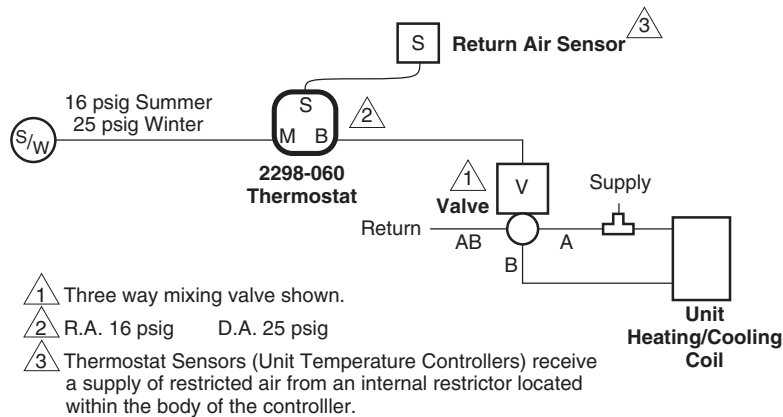

Figure 1 Typical 2298-060 and 2298-063 Summer/Winter Application.

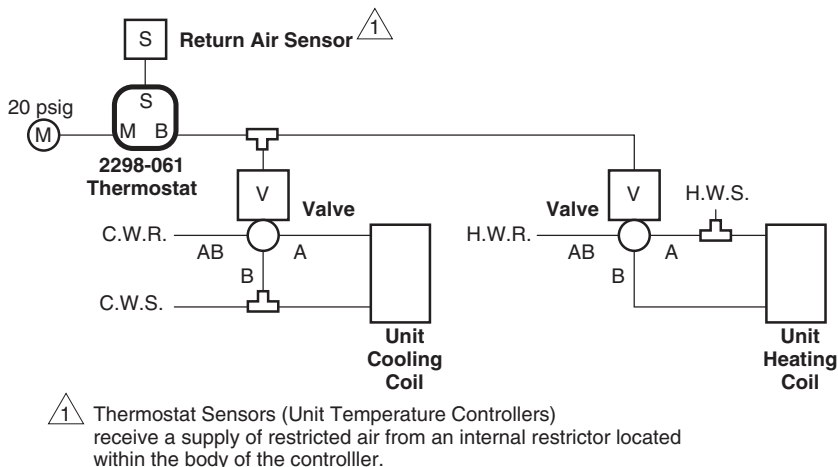

Figure 2 Typical 2298-061 and 2298-062 Heating/Cooling Application.

Table of Contents

Actuator: Linkages	124
Actuator: Maintenance Parts for Discontinued Actuators	128
Modular Pneumatic Panel Components	129
Thermostats: Guards and Covers	132
Thermostats: Installation	135
Thermostats: Tools and Calibration	139
Thermostats: Tubing and Fittings	142
Transmitters: Wells	144
Transmitters: Miscellaneous	146

All specifications are nominal and may change as design improvements are introduced. Schneider Electric shall not be liable for damages resulting from misapplication or misuse of its products.

Accessories and Maintenance Parts
Actuator: Linkages

Application

Damper actuator linkage.

Specifications

- Construction: Shaft and lock nut 4-3/4 L x 5/8 in. (121 x 16 mm).
- AM-533 for use with actuators:
 - MK-3xxx.
 - MK-71xx-0-0-1 (discontinued).
- AM-543 for use with actuator MK-71x1-0-0-2.

AM-543

Actuator Shaft Extension

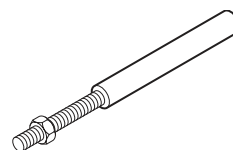

Accessories and Maintenance Parts
Actuator: Linkages

Accessories and Maintenance Parts Actuator: Linkages

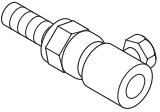
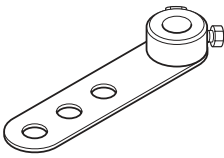

Damper Actuator Accessories for M556, M572, M574, M583, M584				
Illustration	Model No.	Replaces Model No.	Description	For Use With:
	N800-0803	—	Ball-joint/swivel 1/4-20 male x 5/16 in. dia. female. (Receives 5/16 in. push rod.)	—
	21-806	N800-1415	Crank arm for 1/2 in. O.D. extended shaft	M556, M572, M573, M574 actuators
	N800-1414	—	Crank arm for 3/8 in. O.D. extended shaft	

Accessories and Maintenance Parts

Actuator: Maintenance Parts for Discontinued Actuators

Model No.	Replaces Model No.	Description
6-501	20-695 (10-15)	Cover Assembly.
6-053	M503	Diaphragm.
6-054	M504	Diaphragm.
6-055	M505	Diaphragm.
PNV-002	MK-47x1, MK-48x1	Diaphragm.
PNV-251	MK-47x1, MK-48x1	High temperature diaphragm.
PND-145-104	MK-47x1, MK-48x1	Black spring (3 to 8 psi or 5 to 10 psi).
PND-145-107	MK-47x1, MK-48x1	Blue spring (8 to 13 psi).
SYZE-13425	TOOL-100, TOOL-100-500	Gauge.

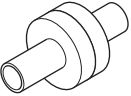
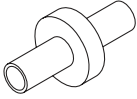
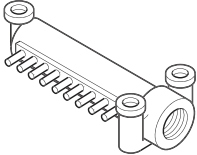
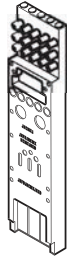
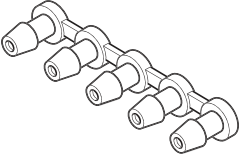
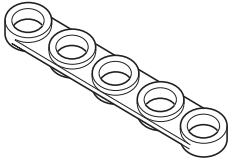
Accessories and Maintenance Parts Modular Pneumatic Panel Components

Illustration	Model No.	Replaces Model No.	Description
	21-152	N100-2500	In-line check valve will operate on 1/4 psi (2.75 kPa) differential. Note: Body is marked IN and OUT.
	21-153	N100-2501	In-line restrictor, 1 scfh. (28.3 l/h) (0.0063 in. (0.160 mm) Dia. restrictor) for use with 2803-500 or 1/4 in. poly tube.
	21-721	N100-2502	Main air header 3/8 in. FPT input port and nine output ports for 2803-500 tubing.
	22-120	MCS-S	22-120 includes socket with 22-130 Installed. Package of 20 22-120. Socket assembly
	2890-520	—	Package of 20 22-120. Socket assembly Note: Use only 2803-500 on 22-120 tubing connections.
	MCS-S-P	—	MCS-S-P includes: One 22-130 One 22-133 Four 22-134 Fifteen 22-140
	22-130	MCS-PS	Replacement plug strip for top access holes in 22-120 (has five barbed plugs). (Included as part of 22-120) socket.
	22-133	MCS-G	Neoprene sealing gasket used when mounting devices on 22-120.
	22-134	MCS-SCREW	#6-1/2 in. double Plastite® mounting screw; mounts devices to 22-120 socket.
	22-135	MCS-MS	#6-1/4 in. mounting screw for mounting 22-121 to backplate, included with 22-121.

Accessories and Maintenance Parts

Modular Pneumatic Panel Components

Illustration	Model No.	Replaces Model No.	Description
A rectangular metal plate with two mounting slots and two screws.	22-136	MCS-EB	Electrical barrier. Covers wiring terminals of 22-122.
A cylindrical component with a T-shaped handle and a stem.	22-137	MCS-CV	Check valve. Mounts on upper end of 22-120 socket.
A T-shaped fitting with a barbed end and a drop-eared gauge mounting port.	22-139	MCS-GMF	Drop-eared gauge mounting fitting, receives 1/8 in. NPT stem-mounted gauge. Has one barbed fitting. Used with 22-121.
A small cylindrical plug with a flange and a stem.	22-140	MCS-PLUG	Sealing plug for sealing unused connections of 22-120 socket. (Connections of unused vertical rows need not be plugged).
A T-shaped fitting with a check valve on one side and a stem on the other.	22-143	MCS-CT	Check valve tee. Mounts on upper end of 22-120 socket; permits connection to field-mounted devices.
A rectangular metal plate with four mounting holes.	22-144	MCS-CP	Cover plate for an unused 22-120 socket.
A roll of polyurethane tubing.	MCS-TUBE	—	500 ft. roll of 9/32 in (7.1 mm). O.D. polyurethane tubing for use with 22-120 Note: All connections to TAC 22-120 socket must be made with MCS-TUBE. Do not attempt to use any other tubing.

Accessories and Maintenance Parts Modular Pneumatic Panel Components

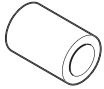
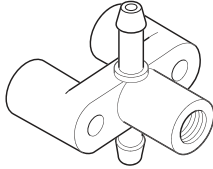
Illustration	Model No.	Replaces Model No.	Description
	22-125	MCS-SC	Neoprene sealing cap for closing poly-tube air lines. Use with 1/4" barbed coupling.
	N100-2366	—	Drop eared gauge mounting tee.

Accessories and Maintenance Parts

Thermostats: Guards and Covers

Application

2 X 2 Thermostat Installation Fittings, Accessories, Adaptors and Tools.

Description

5-3/16 in. sq. cast metal guard. Will fit over 2 x 2 in. or 3 x 3 in. units.

20-707

**Replaces 10-53
Thermostat Guard**

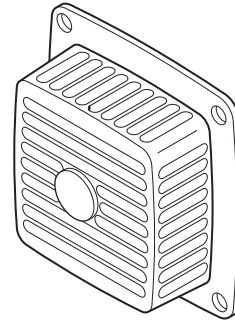

Application

2 X 2 Thermostat Installation Fittings, Accessories, Adaptors and Tools.

Description

Molded Lexan guard for 2 x 2 in. devices. Clear front, satin-chrome enamel base.

20-715

**Replaces 10-62
Thermostat Guard**

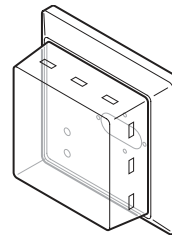

Application

2 X 2 Thermostat Installation Fittings, Accessories, Adaptors and Tools.

Description

Molded ABS guard for 2 x 2 in. devices.

Specifications

- Color: opaque gray.

21-876

**Replaces 10-76
Thermostat Guard**

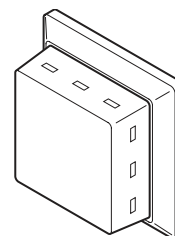

Accessories and Maintenance Parts

Thermostats: Guards and Covers

Application

2 X 2 Thermostat Installation Fittings, Accessories, Adaptors and Tools.

Description

Concealed adjustment cover for use with gray ABS cover.

Specifications

- Color: gray.

21-964

Replaces 10-80

Adjustment Cover

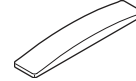

Application

Lock cover screw kit modifies TK Series room thermostats to prevent unauthorized tampering of either the dial setting or the internal mechanism.

Specifications

- Two kits are required for duplex type thermostats.
- Used on all TK-1xxx and TK-5xxx except TK-17xx, TK-18xx.

AT-101

Lock Cover Screw Kit

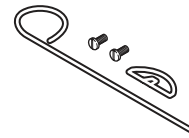

Application

Room thermostat guards protect thermostats from damage and vandalism.

Specifications

- Construction: Wire guard with steel base plate.
- Mounting: To standard outlet or directly to the wall.
- Guard/Thermostat combinations:
 - HKS-5033.
 - TK-1xxx.
 - TK-5xxx.
 - TKS-5001.
 - AT-1163 will accept two single thermostats on an AT-546 auxiliary mounting base.
- Dimensions:
 - AT-1103: 4-1/4 H x 2-5/8 W x 1-5/8 D in. (108 x 67 x 41 mm).
 - AT-1163: 6-1/2 H x 6-5/8 W x 3-1/4 D in. (165 x 168 x 83 mm).

AT-1103, AT-1163

Thermostat Guard

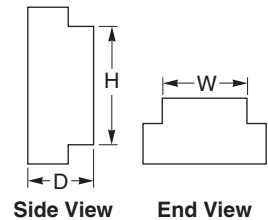
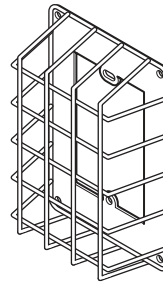

Application

Room thermostat guards protect thermostats from damage and vandalism.

Specifications

- Construction: Cast aluminum guard with steel base plate.
- Mounting: To standard outlet or directly to the wall.
- Guard/Thermostat combinations:
 - HKS-5033.
 - TK-1xxx.
 - TK-5xxx.
 - TKS-5001.
- Dimensions: 4-1/4 H x 3-1/8 W x 1-5/8 D in. (108 x 70 x 41 mm).

AT-1104

Thermostat Guard

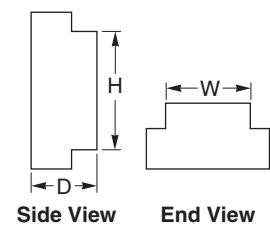
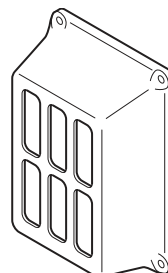

Accessories and Maintenance Parts

Thermostats: Guards and Covers

Application

Room thermostat guard protects thermostats from damage and vandalism.

Specifications

- Construction: Clear plastic guard with solid base and tumbler type key lock.
- Mounting: To standard outlet or directly to the wall.
- Guard/Thermostat combinations:
 - HKS-5033.
 - TK-1xxx.
 - TK-5xxx.
 - TKS-5001.
 - Any 2 x 2 wall mounted device.
- Dimensions: 3-7/8 H x 3-1/2 W x 2-1/2 D in. (98 x 89 x 63 mm).

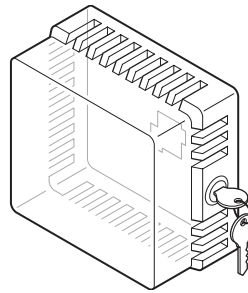

AT-1105
Thermostat Guard

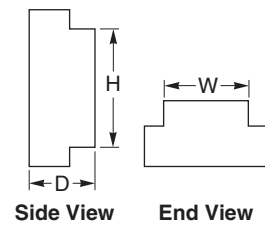

Application

Room thermostat guard protects thermostats from damage and vandalism.

Specifications

- Construction: Clear plastic guard with solid and ring base, tumbler type key lock.
- Mounting: To standard outlet or directly to the wall.
- Included: Mounting ring for installation over installed thermostats without their removal from the wall.
- Guard/Thermostat combinations:
 - HKS-5033.
 - TK-1xxx.
 - TK-5xxx.
 - TKS-5001.
 - Any 2 x 2 wall mounted device.
- Dimensions: 5-1/4 H x 4-5/8 W x 3 D in. (133 x 117 x 76 mm).

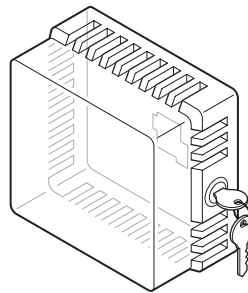

AT-1155
Thermostat Guard

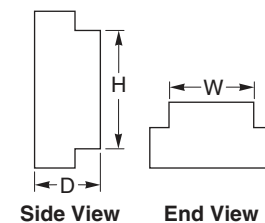

Application

Room thermostat guard protects thermostats from damage and vandalism.

Specifications

- Construction: Clear plastic guard with solid and ring base, tumbler type key lock.
- Mounting: To standard outlet or directly to the wall.
- Included: Mounting ring for installation over installed thermostats without their removal from the wall.
- Guard/Thermostat combinations:
 - HKS-5033.
 - TK-1xxx.
 - TK-5xxx.
 - TKS-5001.
 - Any 2 x 2 wall mounted device.
- Dimensions: 8 H x 5-1/2 W x 3-1/2 D in. (203 x 140 x 89 mm).

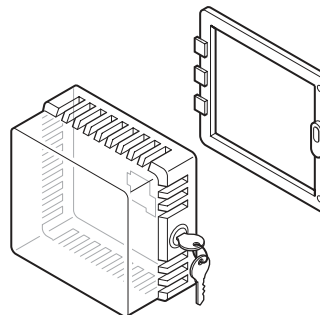

AT-1165
Thermostat Guard

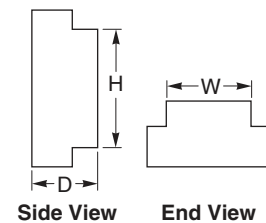

Accessories and Maintenance Parts

Thermostats: Installation

Application

2 X 2 Thermostat Installation Fittings, Accessories, Adaptors and Tools.

Description

Steel mounting ring for mounting thermostat to mounting head. Includes two #6 flat head screws.

20-642

Replaces 6-371
Mounting Ring



Application

2 X 2 Thermostat Installation Fittings, Accessories, Adaptors and Tools.

Description

Stop kit for mounting on base of 2 x 2 in. devices only.

20-712

Replaces 10-59
Stop Kit

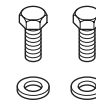

Application

2 X 2 Thermostat Installation Fittings, Accessories, Adaptors and Tools.

Description

10-77: Adaptor plate (molded, black) used to mount 2 x 2 in. devices on 3 x 3 in. hardware. Covers larger hardware so it is not visible.

20-714

Replaces 10-77
Adaptor Plates

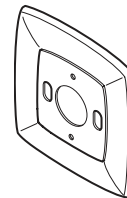

Accessories and Maintenance Parts

Thermostats: Installation

Application

2 X 2 Thermostat Installation Fittings, Accessories, Adaptors and Tools.

Description

Thermostat mounting plate provides 2 x 2 in. device mounting to a 2 x 4 in. vertical or horizontal outlet box. Includes two wing bolt screws.

Specifications

- 20-850: Black
- 10-82-SS: Color: stainless steel.

20-850

Replaces 10-82 and 10-82-SS
Mounting Plates

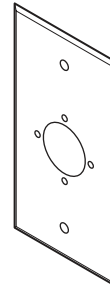

Application

2 X 2 Thermostat Installation Fittings, Accessories, Adaptors and Tools.

Description

Mounting plate for thermostats. Use for dry wall construction. (To be roughed in prior to installation of dry wall.)

21-069

Replaces N5-53
Mounting Plate

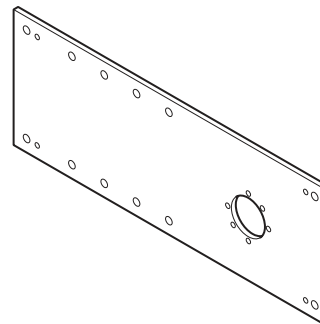

Application

2 X 2 Thermostat Installation Fittings, Accessories, Adaptors and Tools.

Description

Snap-in "labor-saving" fitting for mounting 2 x 2 in. thermostats, humidistats, and transmitters on drywall having at least 3-1/2 in. studs.

21-473

Replaces 10-73
Snap-in Fitting

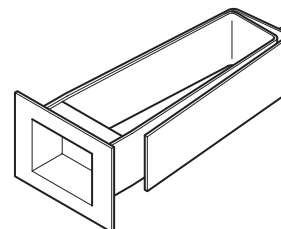

Accessories and Maintenance Parts

Thermostats: Installation

22-022
Replaces N5-95
Thermostat Conversion Kit

This thermostat conversion kit was designed and packaged with the service people in mind. It allows a quick and easy replacement of competitive devices with a new 2211 through 2218 series, 2212-318, 2212-319, 2218-301, and 2220-053 (2 x 2 in.) pneumatic thermostat.

Features:

- Direct replacement of most old or obsolete thermostats.
- Allows replacement without having to remove the old pipe head.
- Wall plate skirt covers marks made by old thermostat.

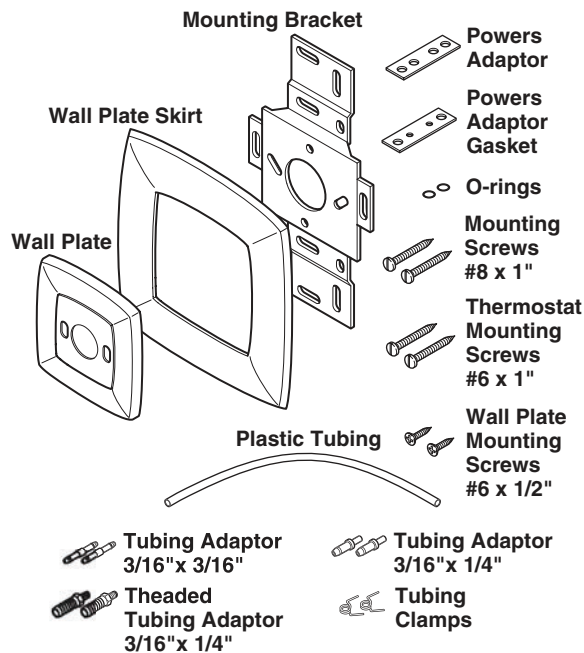

Model Chart		
Model No.	Kit Contains	
	Quantity	Description
22-022	1	Wall plate.
	1	Wall plate skirt.
	1	Mounting bracket.
	2	Tubing adaptor 3/16 x 3/16 in.
	2	Tubing adaptor 3/16 x 1/4 in.
	2	3/16 in. tubing x 1/4 in. threaded adaptor.
	2	O-ring.
	1	Adaptor gasket to replace Powers/Siemens/Lands/Gehr.
	1	Adaptor to replace Powers/Siemens/Lands/Gehr.
	2	Mounting screw no. 8 x 1 in..
	2	Wall plate mounting screws no. 6 x 1/2 in.
	2	Thermostat mounting screws no. 6 x 1 in.
	2	Tubing clamps.
	1	1/4 in. O.D. plastic tubing.

Accessories and Maintenance Parts

Thermostats: Installation

Application

Single room type electric or pneumatic thermostats, sensing elements and electronic controllers or sensing elements. Used to cover a rough plaster hole in the wall. Use with AT-505 sub-base for surface mounting applications.

Specifications

- Color: Beige.
- Dimensions: 5-7/16 H x 3-7/8 W x 3/8 D in. (138 x 98 x 16 mm).

AT-504

Mounting Base Single

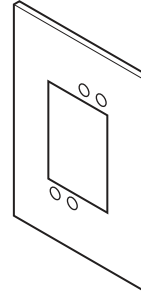

Application

Two single wall type thermostats, controllers or sensing elements for dual function control. Can be installed on a horizontally mounted switch box by mounting an AT-504 on the AT-546.

Specifications

- Color: Beige.
- Dimensions: 6-1/4 H x 6-1/4 W x 1/4 D in. (159 x 159 x 6 mm).

AT-546

Mounting Base Dual

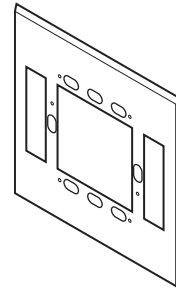

Accessories and Maintenance Parts

Thermostats: Tools and Calibration

Application

2 X 2 Thermostat Installation Fittings, Accessories, Adaptors and Tools.

Description

Gauge tap adaptor for T15 or T16 only. One end accepts 1/8 in. MPT gauge, other end screws into thermostat body.

20-706

Replaces 10-51
Gauge Adaptor

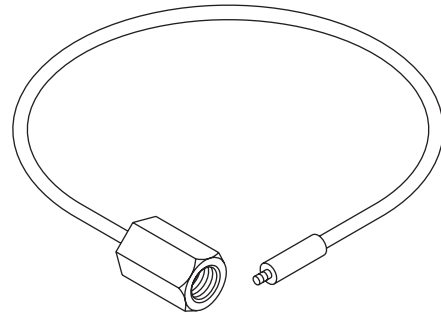

Application

2 X 2 Thermostat Calibration Tool.

Description

1/16 in. and 1/4 in. hex head thermostat calibration and cover-screw wrench. (Also adjusts 2341 Series Receiver-Controllers.)

20-881

Replaces N2-4
Calibration and Cover-screw Wrench

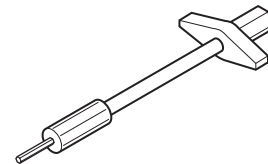

Application

2 X 2 Thermostat Installation Fittings, Accessories, Adaptors and Tools.

Description

Gauge adaptor for 2 x 2 thermostats

22-138

Replaces MCS-GA
Gauge Adaptor

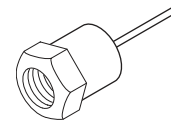

Accessories and Maintenance Parts

Thermostats: Tools and Calibration

Application

Pneumatic thermostat calibration kit for 2 x 2 Thermostats.

900-002

Calibration Kit

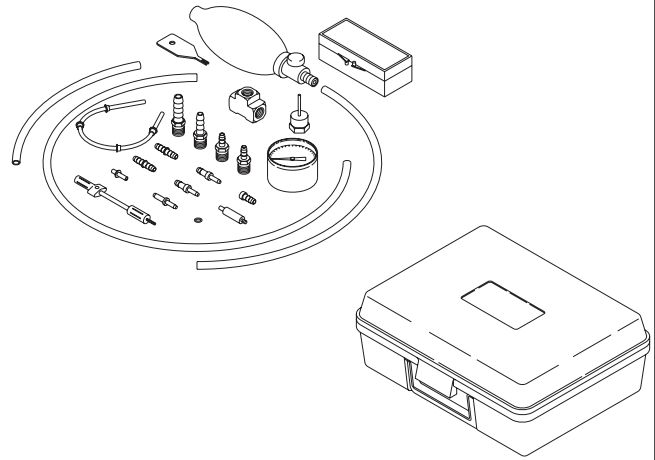
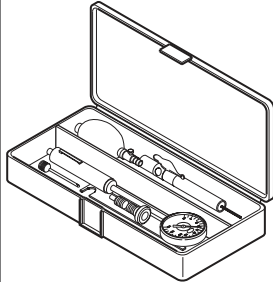
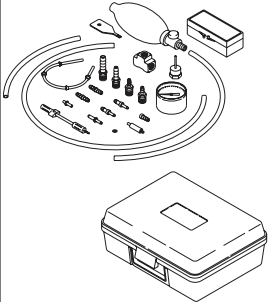

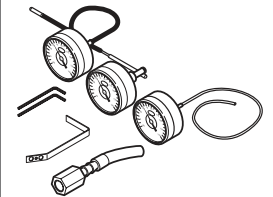
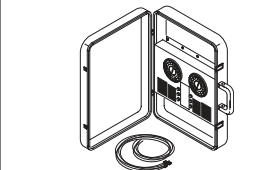

Illustration	Model No.	Description
	TOOL-078	Adaptor for test gauge TOOL-077 to branch test port for HK-1x12, TK-1xxx, T K-6xxx, TK-8xxx, TK-9xxx, and TK-1xxxx type pneumatic thermostat. Also included in TOOL-095-1 and TOOL-096.
	TOOL-082	Pocket wrench with 5/64 in. Allen wrench for branch test port on TK Series pneumatic thermostats and locking cover screws and 0.048 in. 6-spline wrench for thermostat calibration.
	TOOL-087	Needle and adaptor for use with 1/4 in. plastic tubing for TK Series thermostats.
	TOOL-091	Branch test adaptor without gauge for Johnson thermostats. Also included in TOOL-090.

Accessories and Maintenance Parts

Thermostats: Tools and Calibration

Illustration	Model No.	Description
	TOOL-095-1	<p>Pneumatic calibration tool kit. Calibrates all TAC pneumatic equipment.</p> <p>Kit includes:</p> <ul style="list-style-type: none"> • 22-138, gauge adaptor. • 20-881, 2 x 2, 1/16 in. hexhead thermostat calibration cover screw wrench. • Female branch tee (1/4 barb x 1/4 barb x 1/8 in. FPT). • TOOL-011: calibration wrench. • TOOL-078: adaptor. • TOOL-080-1: changeover wrench. • TOOL-082: combination wrench. • TOOL-083: thermostat calibration wrench. • TOOL-085: hand pump bulb. • TOOL-087: needle and adaptor. • TOOL-110: 3/32 in. hex wrench. • AL-362: 0 to 30 psi (0 to 206 kPa) gauge. • Air line tubing for barbed fitting. • Air line tubing with compression fitting. • 3/16 x 4 in. blade screwdriver.
	900-002	Pneumatic thermostat calibration kit for 2" x 2" Thermostats.
	900-012	Pneumatic calibration kit.
	TOOL-096	<p>Pneumatic thermostat calibration kit, for TK-Series thermostats.</p> <p>Kit includes:</p> <ul style="list-style-type: none"> • TOOL-076: adaptor. • TOOL-077: adaptor. • TOOL-078: adaptor. • TOOL-080-1: changeover wrench. • TOOL-083: thermostat calibration wrench. • TOOL-111: 5/64 in. Allen wrench. • TOOL-112: 7/64 in. Allen wrench. • Three AL-362, 0 to 30 psi (0 to 206 kPa) gauges
	TOOL-100-500	Calibration instrument for pneumatic transmitter/receiver controller systems.

Accessories and Maintenance Parts

Thermostats: Tubing and Fittings

Application

2 X 2 Thermostat Installation Fittings, Accessories, Adaptors and Tools.

Description

3/16 in. tygothane tubing assembly with spring. One tube with four eyelets, but no fittings.

20-693

Replaces 10-11
Tubing

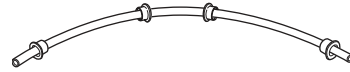

Application

2 X 2 Thermostat Installation Fittings, Accessories, Adaptors and Tools.

Description

3/16 in. tygothane tubing assembly, with spring, two eyelets, and two barbed fittings for 1/4 in. plastic tubing.

20-717

Replaces 10-64
Tubing

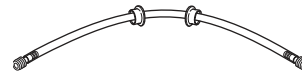

Application

2 X 2 Thermostat Installation Fittings, Accessories, Adaptors and Tools.

Description

Used for transmitters and bleed type units. 1.0 scfh (28.32 l/h) restrictor (1/4 in. O.D. compression) for use on 1/4 in. O.D. copper tubing or can be used on polyethylene with insert.

Also Replaces:

AT-532-098-1-1
AT-532-111-1-03

20-944

Replaces N4-32
Restrictor

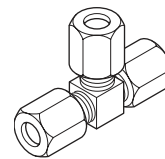

Application

2 X 2 Thermostat Installation Restrictor, Restrictor Tees, and Thermostat Calibration Kit.

Description

1.0 scfh (28.32 l/h) restrictor tee for use with one-pipe thermostats or transmitters (1/4 in. polyethylene or polyurethane tubing). Color: red.

Also Replaces:

AT-532-111-1-01
AT-532-111-1-02
AT-532-222-2-01

Use two 21-038 to replace AT-532-222-2-02

21-038

Replaces N100-0010 (N100-10)
Restrictor Tee

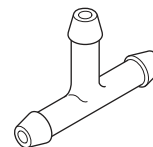

Accessories and Maintenance Parts

Thermostats: Tubing and Fittings

Application

2 X 2 Thermostat Installation Restrictor, Restrictor Tees, and Thermostat Calibration Kit.

Description

0.5 scfh (14.16 l/h) restrictor tee. Color: light green.

Note: For use with the 2298 series temperature controllers. This restrictor should be used only (a) when the 100-50 (RA) or 100-51 (DA) temperature sensors are used separately, or (b) for special applications requiring low air flow.

Also Replaces:

AT-532-098-1-2

AT-532-098-1-3

21-039

Replaces N100-0005 (N100-5)

Restrictor Tee

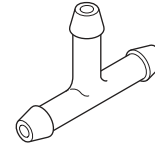

Application

2 X 2 Thermostat Installation Restrictor, Restrictor Tees, and Thermostat Calibration Kit.

Description

Used for transmitters and bleed type units. 1.0 scfh (28.32 l/h) in-line restrictor.

21-153

Replaces N100-2501

In-line Restrictor

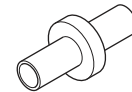

Application

Optional. 2252 series transmitter accessory.

Specifications

- 3/8 x 7-1/32 in. copper well with 1/2 in. NPT bushing.
- 2252 series transmitter require 20-803 adapter.
- Assemble using M-500 thermal compound.

20-778

Replaces 100-17

Copper Well

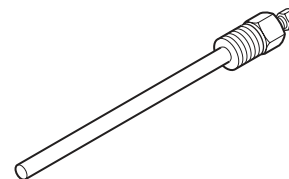

Accessories and Maintenance Parts

Transmitters: Wells

Application

Standard. 2252 series transmitter accessory.

20-782

Replaces 100-25

Copper Well

Specifications

- 3/8 x 10-17/32 in. copper well with 1/2 in. NPT bushing.
- Assemble using M-500 thermal compound.

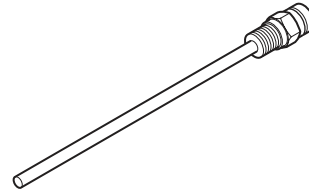

Application

Adapts existing female threaded wells (7/16 in. — 24) for T150 set screw mounting. T150 transmitter accessory.

Neck extension adaptor-converts 7-1/32 in. well to 10-17/32 in. well.

20-803

Replaces 100-47

Adaptor



Application

2252 series transmitter accessory.

20-805

Replaces 100-49

Stainless Steel Well

Specifications

- 3/8 x 7-1/32 in. stainless steel well with 1/2 in. NPT bushing.
- Includes 20-803.
- Assemble using M-500 thermal compound.

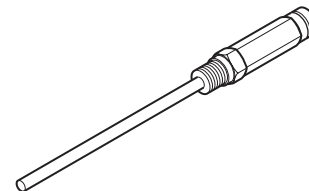

Application

Adaptor, brass, for mounting T150 Immersion Transmitter in AT-201 or AT-203 well.

22-401

Replaces 100-71

Adaptor



Accessories and Maintenance Parts

Transmitters: Wells

Application

Immersion well for use with 3/8 in. (10 mm) temperature bulbs.

AT-201, AT-203, AT-206

Immersion Well

Specifications

- Ambient temperature limits: -40 to 350°F (-40 to 177°C).
- Assemble using M-500 thermal compound.

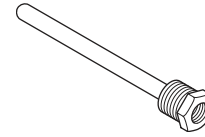

Model No.	Material	Dimensions				Application Limitations at 250°F (121°C) Fluid Temp.		Used With
		O.D. in. (mm)	Insertion Length in. (mm)	Overall Well Length in. (mm)	Fitting in.	Max. Recom. Velocity FPS (m/s)	Max. Recom. Static Pressure psig (kPa)	
AT-201 ^a	Copper	1/2 (13) ^b	9-1/2 (241)	10-1/4 (260)	3/4 MNPT	11 (3.3)	250 (1728)	TK-6024, TK-6124
AT-203 ^a	Stainless Steel	1/2 (13) ^b	9-1/2 (241)	10-1/2 (267)	3/4 MNPT	20 (6.1)	500 (3448)	
AT-206	Copper	1/2 (13) ^b	4-1/2 (114)	5-13/16 (148)	1/2 MNPT	11 (3.3)	250 (1728)	

^a Requires AT-209 for TK-6024, TK-6124.
^b For 3/8 in. (10 mm) diameter bulbs.

Application

Duct mounting kit for pneumatic temperature bulbs.

AT-208

Duct Mounting Kit

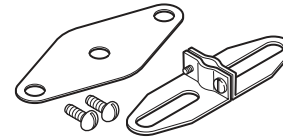

Application

3/4 in. MNPT liquid line or tank mounting kit for TK-6024 or TK-6124 Series bulb thermostats. Bulb well is recommended.

AT-209

Liquid Line or Tank Mounting Kit

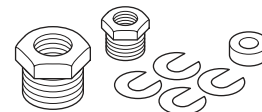

Accessories and Maintenance Parts

Transmitters: Miscellaneous

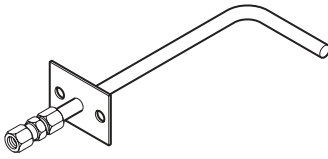
Application Duct static pressure sensing tips.		AP-302 Pressure Sensing Tip			
Specifications • Mounting hardware: Provided.					
Model No.	Type of Connection	Construction	Mounting Location	Dimensions in. (mm)	For Use With
AP-302	1/4 in. compression fitting for plastic or copper tubing	Brass	Areas with air turbulence caused by filters, dampers, etc.	Insertion length 4 (102); 5 L x 2-1/2 W (127 x 64)	2323-5xx, 2374-401, 2374-410

Life Is On | **Schneider**
Electric

Schneider Electric

www.schneider-electric.com

F-27383-4